

- A WATER FILLER CAP, FRESH WATER
- B OIL FILLER CAP, ENGINE
- C OIL DIPSTICK, ENGINE LEFT OR RIGHT SIDE MOUNTED
- D ENGINE CONTROL UNIT
- E OIL DRAIN PIPE, ENGINE n 12.5
- F OIL FILTER MAIN
- G OIL FILTER BYPASS
- H LIFTING EYE
- I WATER DRAIN, FRESH WATER
- J WATER DRAIN, SEA WATER
- K AIR FILTER
- L FUEL FILTER
- M HOT WATER OUTLET n 16
- N HOT WATER INLET n 16
- O ELECTRICAL FUSES (ONLY 24V)
- P SEA WATER INLET n 50
- Q OIL DIPSTICK REVERSE GEAR
- R CENTRE OF GRAVITY
- T OIL DRAIN REVERSE GEAR
- U FUEL INLET CONNECTION
- V FUEL RETURN TO TANK
- X ENGINE STOP
- Y CRANKCASE VENTILATION
- Z EXHAUST RISER n 127 (5') (OPTION)
- AA SEA WATER PUMP
- AB EXHAUST ELBOW n 127 (5')
- AC EXTRA ALTERNATOR
- AD DIAGNOSE CONNECTOR
- AE ELASTIC SUSPENSION (4x)
- AF DATA LINK, SENDER AND AUX (2x)

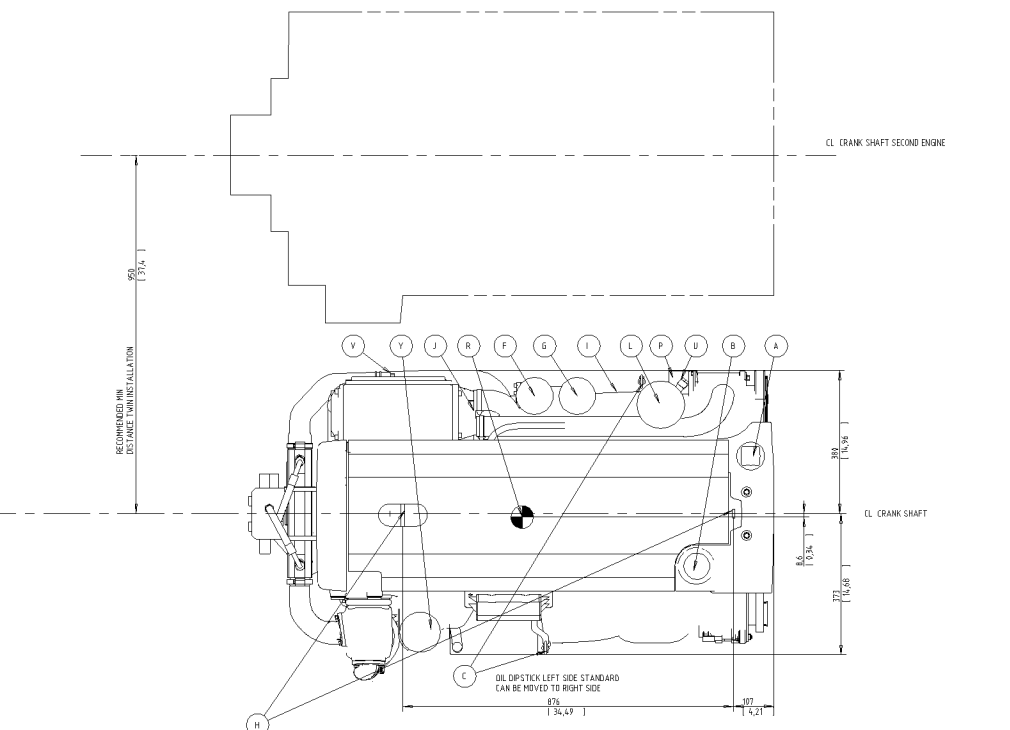
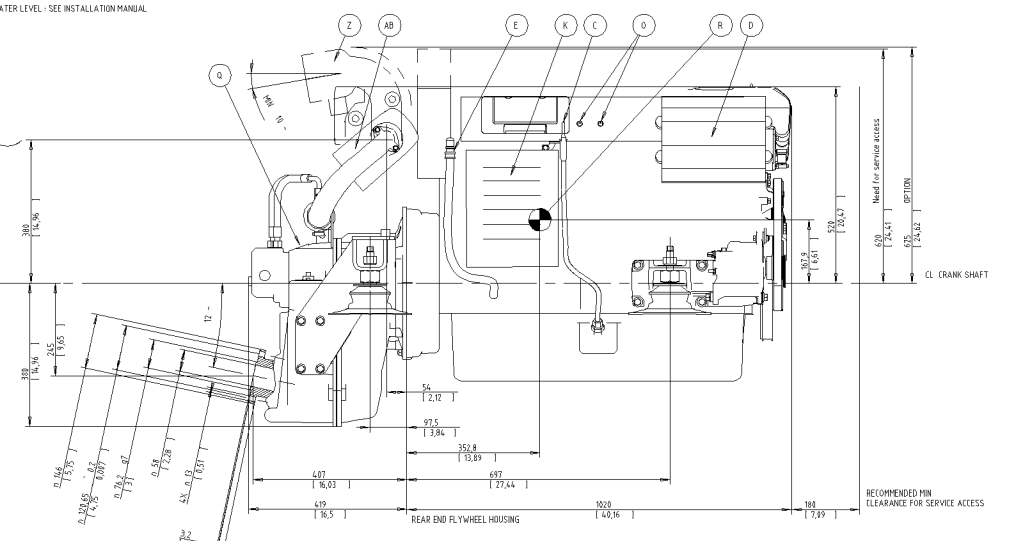
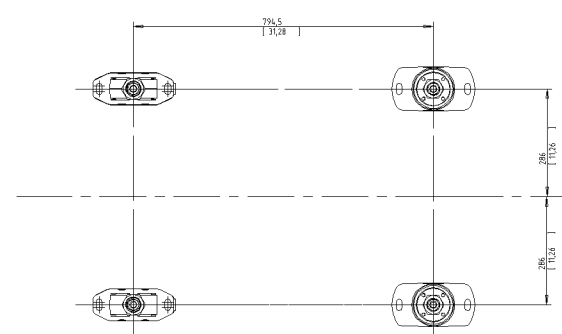
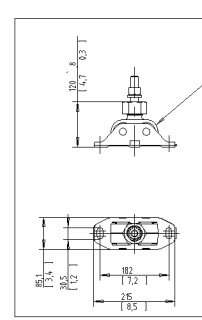
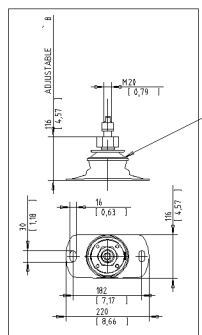

SCALE 1:5

<p>VOLVO PENTA</p>		<p>ENGINE DIMENSIONS P6A-P6B-ENGINE</p>	
<p>21912426</p>		<p>DIMENSION DRAWING</p>	

Plus d'informations sur : www.dbmoteurs