



## Marine Propulsion Systems

ZF 4-1 M  
ZF 5 M  
ZF 6 M  
ZF 10 M  
ZF 12 M  
ZF 15 M  
ZF 15 MA  
ZF 15 MIV  
ZF 25 M  
ZF 25 MA  
ZF 30 M



<b>IT</b>	MANUALE D'USO
<b>EN</b>	OPERATING MANUAL
<b>DE</b>	BETRIEBSANLEITUNG
<b>FR</b>	MANUEL DE SERVICE
<b>ES</b>	MANUAL DE USO
<b>NO</b>	BRUK OG VEDLIJEHOLD
<b>PT</b>	MANUAL DE OPERAÇÃO
<b>NL</b>	GEBRUIK EN ONDERHOUD
<b>FI</b>	KÄYTTÖ JA HUOLTO
<b>EL</b>	ΕΓΧΕΙΡΙΔΙΟ ΧΕΙΡΙΣΤΗ
<b>HR</b>	RADNI PRIRUČNIK

310.01.0006g

Plus d'informations sur : [www.dbmoteurs.fr](http://www.dbmoteurs.fr)

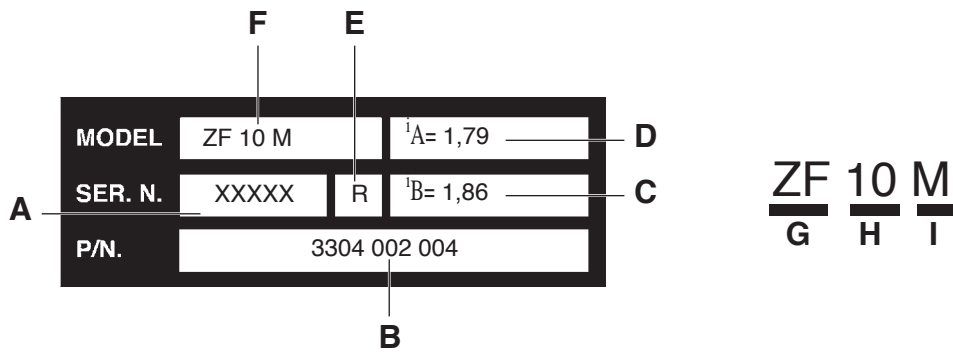

Fig. 1

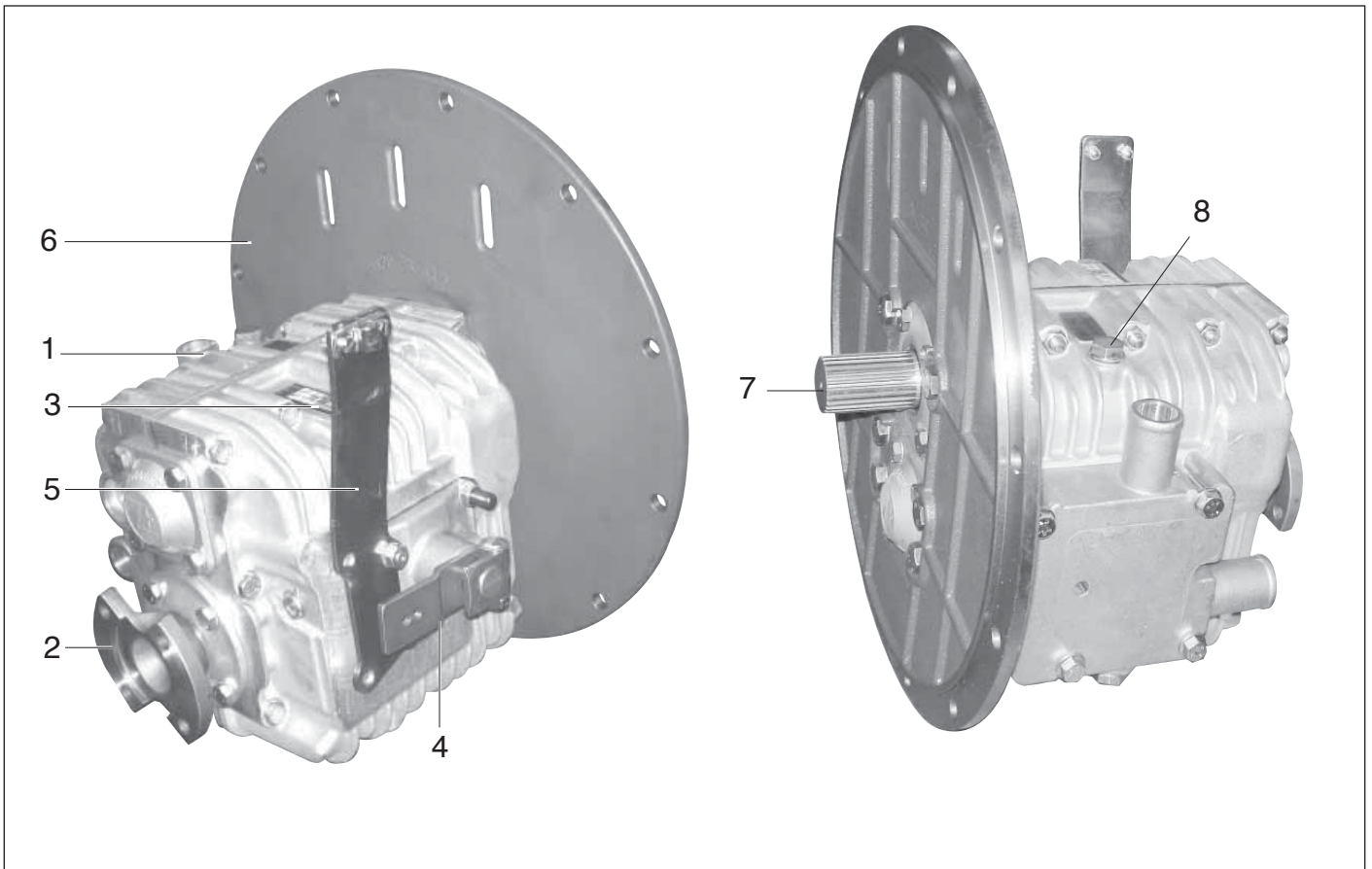

Fig. 2

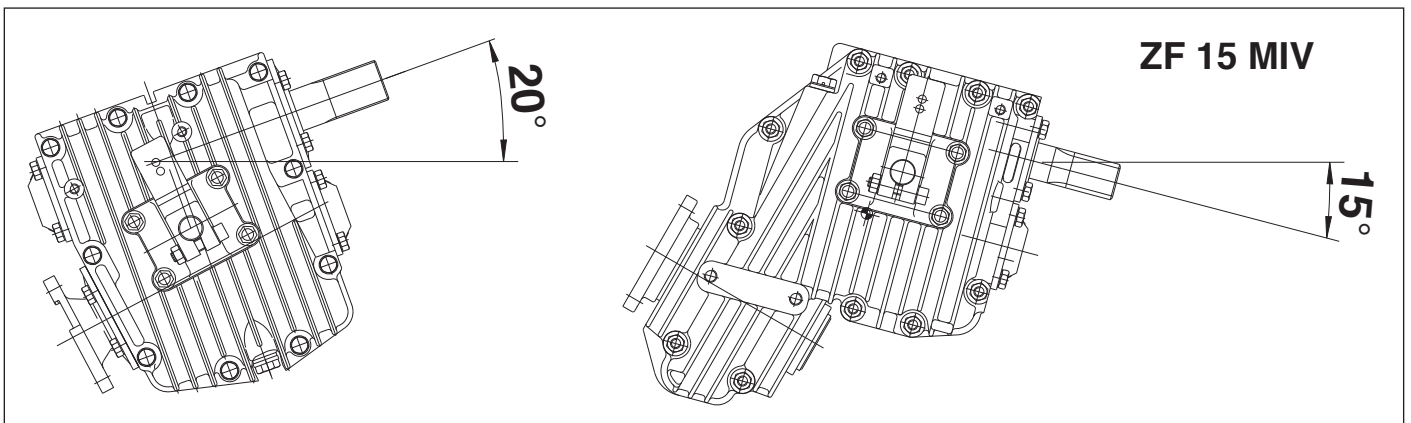

Fig. 3

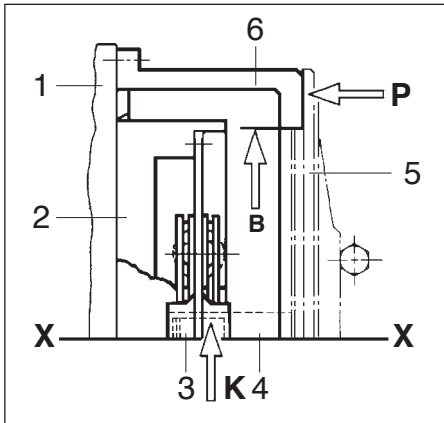

Fig. 4

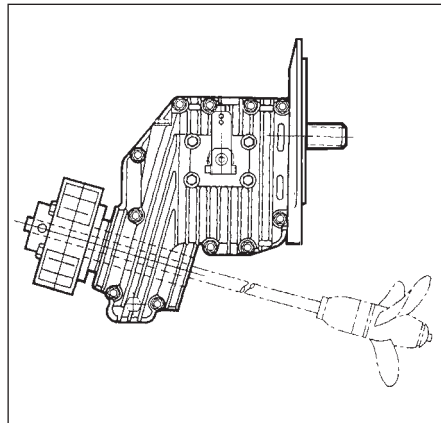

Fig. 5

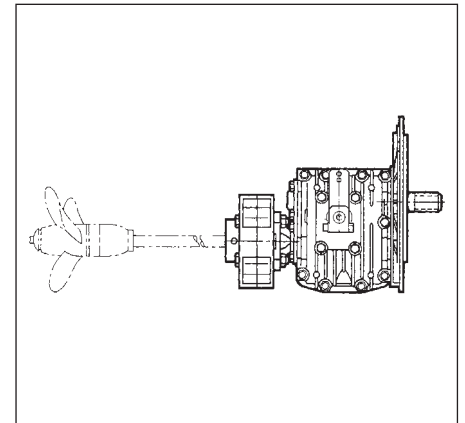

Fig. 6

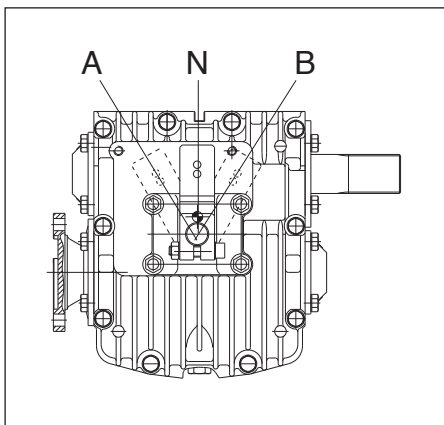

Fig. 7

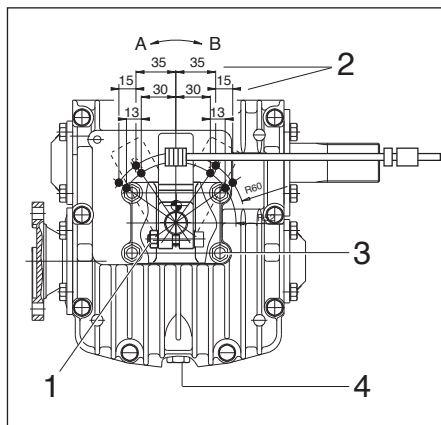

Fig. 8

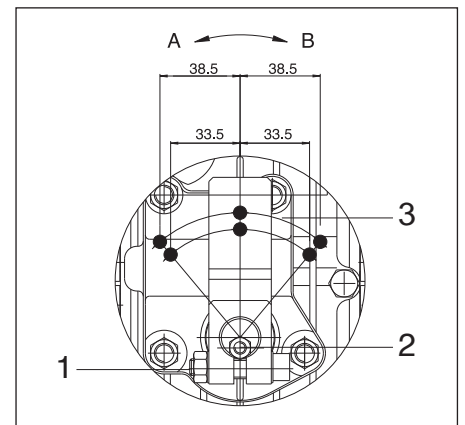

Fig. 9

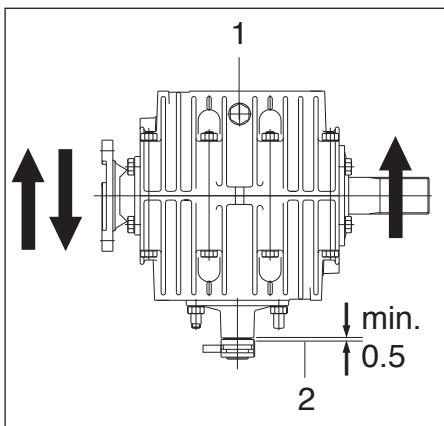

Fig. 10

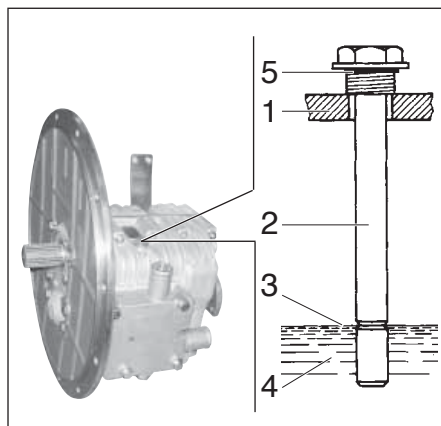

Fig. 11

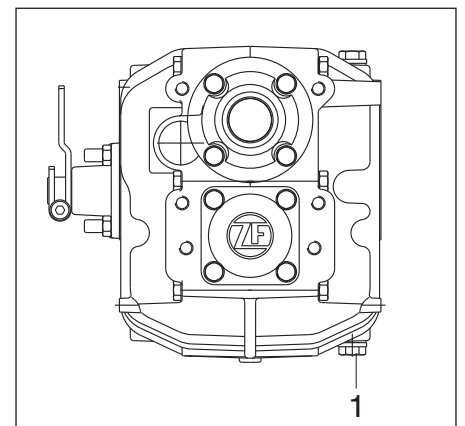

Fig. 12



---

<b>IT</b>	Italiano	5
<b>EN</b>	English	12
<b>DE</b>	Deutsch	19
<b>FR</b>	Français	26
<b>ES</b>	Español	33
<b>NO</b>	Norsk	40
<b>PT</b>	Português	47
<b>NL</b>	Nederlands	54
<b>FI</b>	Suomi	61
<b>EL</b>	Elinika	68
<b>HR</b>	Hrvatski	75

---

## ITALIANO

### Contenuto

1.1	Introduzione.....	5
2.1	Identificazione dell'invertitore .....	5
3.1	Descrizione.....	5
4.1	Installazione .....	5
5.1	Funzionamento.....	6
6.1	Manutenzione.....	7
7.1	Ricerca guasti.....	8
8.1	Dati tecnici.....	9
9.1	Garanzia.....	11
10.1	Fluido di trasmissione ATF .....	82
11.1	Lista punti di assistenza .....	83
12.1	Disegni di installazione.....	84
13.1	Warranty card.....	95

## 1.1 Introduzione

### 1.1.1 RESPONSABILITÀ DEL CLIENTE

Il cliente operatore è responsabile che i controlli per assicurare che la lubrificazione, il raffreddamento, la manutenzione e tutto ciò raccomandato in questo manuale siano strettamente seguiti per fare in modo che l'invertitore funzioni regolarmente ed in piena sicurezza.

Ogni invertitore è coperto da garanzia, di conseguenza per la validità della stessa, le istruzioni contenute in questo manuale sono da seguire scrupolosamente.



#### ATTENZIONE

**Il produttore non è responsabile per qualsiasi danno o perdita causati da errate installazioni, uso sbagliato dell'attrezzatura e insufficiente manutenzione. Il Cliente si deve assicurare che non siano presenti alcune forze esterne come vibrazioni torsionali, causate da torsione e da flessione.**

**L'interazione tra motore albero ed l'elica può portare a vibrazioni torsionali producendo un martellante rumore degli ingranaggi con la possibilità di danneggiare il motore e/o l'invertitore.**

**Il Costruttore non è responsabile di tali vibrazioni torsionali inerenti all'installazione.**

Questo manuale è costituito dai seguenti tre capitoli principali:

### 1.1.2 DESCRIZIONE

Questa parte descrive brevemente la funzione, l'utilizzo e le parti dell'invertitore ZF M.

### 1.1.3 UTILIZZO

Questa parte descrive le procedure di utilizzo e tutte le necessarie misure di sicurezza.

### 1.1.4 MANUTENZIONE

Questa parte contiene tutte le indicazioni di manutenzione e di servizio che devono essere svolte dall'operatore.

Con i termini «sinistro, destro, babordo e tribordo» usati in questo manuale, ci si riferisce sempre ad invertitori installati in direzione della marcia avanti. Importanti informazioni riguardanti l'affidabilità tecnica e la sicurezza nell'utilizzo sono evidenziate nel seguente modo:



#### PERICOLO

**Tutte le procedure, le pratiche, le condizioni e le raccomandazioni, ecc., che non vengono accuratamente seguite, possono causare un danno o la morte dell'operatore.**



#### ATTENZIONE

**Tutte le procedure, le pratiche, le condizioni e le raccomandazioni, ecc. se non vengono accuratamente seguite, possono causare un danno o la distruzione dell'attrezzatura.**

**NOTA:** Si riferiscono ad aspetti tecnici per i quali l'utilizzatore dell'attrezzatura deve prestare particolare attenzione.

**PERICOLO, ATTENZIONE e NOTA** precedono sempre il testo a cui si riferiscono.

## 2.1 Identificazione dell'invertitore

La targa di identificazione è applicata sull'invertitore.

La Fig. 1 riporta un esempio di targa di identificazione:

- A** Numero di serie dell'invertitore.
- B** Codice della trasmissione.
- C** Rapporto di trasmissione per elica che ruota nella stessa direzione del motore.

**D** Rapporto di trasmissione per elica che ruota in direzione opposta a quella del motore.

**E** Ogni anno è assegnata una diversa lettera progressiva.

**F** Tipo di invertitore.

Significato delle designazioni degli invertitori:

**G** Tipo di invertitore.

**H** Grandezza dell'invertitore.

**I** Versione dell'invertitore.

## 3.1 Descrizione

Gli invertitori marini ZF M sono delle trasmissioni ad ingranaggi elicoidali comandate da un meccanismo automatico.

Essi si distinguono per la loro robustezza e affidabilità. Nondimeno si raccomanda che siano scrupolosamente osservate le seguenti istruzioni per l'installazione, l'uso e la manutenzione.

Il non osservare le istruzioni contenute in questo manuale o ogni modifica all'invertitore non autorizzata, preclude la validità della garanzia.

Su richiesta il costruttore può fornire il manuale di riparazione.

Fig. 2:

- 1) Scambiatore
- 2) Flangia di uscita
- 3) Targa di identificazione
- 4) Leva di azionamento.
- 5) Staffa telecomando.
- 6) Campana.
- 7) Albero d'ingresso
- 8) Asta livello olio

## 4.1 Installazione

Quando si installa un invertitore ZF M devono essere scrupolosamente seguite le seguenti indicazioni:

- L'installazione deve essere eseguita solo da personale specializzato.
- **POSIZIONE INCLINATA** (Fig. 3): La posizione della trasmissione, rispetto all'albero di entrata, non deve eccedere di un angolo di 20° (15° per ZF MIV), in servizio continuo. Per quanto riguarda l'inclinazione laterale permessa contattare il costruttore.
- **GIUNTO ELASTICO:** Tra motore e invertitore è necessario montare un giunto di accoppiamento elastico con gioco radiale minimo (0.5 mm); tra invertitore ed asse elica, è rac-

comandato un accoppiamento con giunto flessibile.

• **ACCOPIAMENTO MOTORE/TRASMISSIONE** (Fig. 4):

- 1) Flangia motore.
- 2) Volano.
- 3) Giunto elastico.
- 4) Albero dell'invertitore.
- 5) Flangia invertitore.
- 6) Flangia volano.

Valori massimi ammissibili radiali ed assiali X: B-0,1 mm.

• **ACCOPIAMENTO TRASMISSIONE/ASSE D'ELICA** (Fig. 5 - 6):

- Scegliere un adeguato scambiatore di calore.

Per maggiori dettagli consultare il manuale di installazione.

**Tipo di olio:** ATF (Fluido Automatico per Trasmissioni) vedi cap.10.1.

## 5.1 Funzionamento

Tutte le trasmissioni subiscono un test di collaudo prima della spedizione.

In normali condizioni di funzionamento è consentita l'inversione di marcia solo quando il motore è al minimo dei giri. In casi di emergenza è comunque consentita l'inversione anche a più alti giri.

La corretta funzionalità del circuito idraulico è assicurata solo se vengono cambiati regolarmente il fluido idraulico, come previsto nella manutenzione programmata. (Vedi capitolo 6.1).

Controllare di tanto in tanto visivamente la presenza di eventuali perdite di olio.



### PERICOLO

**Intervenire sull'invertitore solo quando sia il motore che l'elica sono fermi.**



### ATTENZIONE

**Al momento del primo avviamento la trasmissione deve essere riempita con il previsto olio idraulico. Per le procedure di riempimento, tipo di fluido, quantità e livello, vedi capitolo 6.1.4.**



### ATTENZIONE

**L'uso dell'invertitore con una insufficiente quantità di fluido danneggia gli ingranaggi.**

**Una eccessiva quantità di olio può causare perdite alle guarnizioni di tenuta e allo sfiato e può far aumentare considerevolmente la temperatura di funzionamento.**

### 5.1.1 MESSA IN FUNZIONAMENTO



#### ATTENZIONE

**Prima di mettere in funzione l'invertitore controllare il livello dell'olio (vedi capitolo 6.1.1).**



#### ATTENZIONE

**In normali condizioni di funzionamento le leva di inversione deve essere azionata con il motore al minimo.**

**Inversioni effettuate a più alto numero di giri possono portare un sovraccarico ai dischi della frizione e questo deve essere evitato durante il normale funzionamento.**

**NOTA:** In caso di emergenza può essere effettuata l'inversione da marcia avanti a marcia indietro con motore funzionante ad alta velocità.

### POSIZIONI DI FUNZIONAMENTO

(Fig. 7):

A = Verso di rotazione dell'elica opposto e quello del motore.

N = Posizione di folle

B = Verso di rotazione dell'elica uguale a quello del motore.



### PERICOLO

**Avviare il motore solo quando la leva di azionamento si trova in posizione di folle.**

La temperatura normale d'esercizio dell'olio della trasmissione deve essere compresa tra 50°C (122°F) e 80°C (176°F).

È permesso raggiungere solo per un breve periodo di tempo la massima temperatura di 100°C (212°F) ammesse per l'olio ATF.



### ATTENZIONE

**Se la temperatura è troppo alta, fermate immediatamente il motore, controllate il livello del fluido nell'in-**

**vertitore e il corretto funzionamento dello scambiatore di calore.**

**Non ripartite se la causa del malfunzionamento non è stata eliminata.**

### 5.1.2 NAVIGAZIONE A VELA RIMORCHIO O ANCORAGGIO

Quando il motore è spento e l'imbarcazione naviga a vela, sia da rimorchiata o che si trovi ancorata, l'elica può ruotare per effetto della corrente.

Questo non danneggia la trasmissione. In una imbarcazione con due motori, quando uno solo è in funzione, l'elica di quello spento può ruotare liberamente.

Quando il motore è spento la posizione della leva di comando è irrilevante.



### ATTENZIONE

**Con l'asse dell'elica in posizione libera la posizione della leva di comando deve essere in «N» (Fig. 7). Utilizzare la posizione di comando contraria a quella di avanzamento se si vuole bloccare l'asse dell'elica, in caso contrario si ha il danneggiamento della trasmissione.**



### PERICOLO

**Non eseguire alcun intervento nella trasmissione durante il traino o quando l'imbarcazione è ancorata in un fiume in quanto l'elica può ruotare.**



### PERICOLO

**Non eseguire alcun intervento nella trasmissione di una installazione doppia quando uno dei due motori è acceso. L'elica di quello fermo può ruotare.**



### PERICOLO

**Quando il motore gira al minimo e si desidera che l'elica non giri (per esempio se si deve caricare la batteria con la barca ferma), la leva di comando deve trovarsi in posizione neutrale N (Fig. 7).**

**Evitare di fare girare l'invertitore idraulico in posizione neutrale ad alto numero di giri per lunghi periodi.**



### 5.1.3 SISTEMA DI COMANDO



#### ATTENZIONE

Controllare che il cavo di comando si muova liberamente.

#### CORSA UTILE:

Mod: **ZF 5 M - 6 M - 10 M - 12 M - 15 M - 15 MA - 15 MIV - 25 M - 25 MA - 30 M.**

La corsa utile minima (N-A=N-B) della leva di comando, misurata sul foro di attacco esterno, deve essere di almeno 35 mm; se misurata su quello interno di almeno 30 mm.

#### Fig. 8:

- 1) Vite di fissaggio leva coppia di serraggio  $22 \pm 1$  Nm.
- 2) Corsa minima per il cavo di comando.
- 3) **Non** smontare il coperchio di comando.
- 4) Tappo scarico olio.  
Coppia di serraggio: Ma = 22 Nm (16 lb-ft).

#### CORSA UTILE:

Mod: **ZF 4-1 M**

La corsa utile (N-A=N-B) della leva di comando, misurata sul foro di attacco esterno, deve essere di  $38,5 \pm 1,5$  mm, se misurata su quello interno di 33,5 mm.

Dalla posizione di folle, quando la leva ruotando compie un angolo di  $10^\circ$ - $12^\circ$ , essa comincia a muoversi anche in direzione perpendicolare verso l'esterno e si arresta a fine corsa (angolo di  $40^\circ$ ).

#### Fig. 9:

- 1) Vite di fissaggio leva coppia di serraggio  $22 \pm 1$  Nm.
- 2) Non allentare il dado.
- 3) **Non** smontare il coperchio di comando.

**POSIZIONE DELLA LEVA:** In posizione di folle deve trovarsi in posizione perpendicolare al cavo di comando.

La leva può essere ruotata e fissata poi in qualsiasi posizione tramite la vite di serraggio. La leva si deve trovare alla distanza minima dal coperchio di 0,5 mm. Lo smontaggio, od anche il solo allentamento delle viti del coperchio, richiede un nuovo aggiustamento dello

stesso (da effettuarsi solo da personale autorizzato).

#### Fig. 10:

- 1) Asta dell'olio e tappo di riempimento dell'olio (17 mm)  
Coppia di serraggio: Ma = 20 Nm (15 lb-ft).
- 2) Distanza leva comando dal coperchio min 0,5 mm.

**CONTROLLI:** Al fine di garantire il buon funzionamento è necessario controllare con regolarità la posizione della leva.

## 6.1 Manutenzione

### 6.1.1 CONTROLLO DEL LIVELLO DELL'OLIO



#### PERICOLO

**Non eseguire alcun intervento nella trasmissione durante il traino o quando l'imbarcazione è ancorata in un fiume in quanto l'elica può ruotare.**

#### DESCRIZIONE ASTA OLIO (Fig. 11):

- 1) Superficie scatola.
- 2) Asta livello olio.
- 3) Livello olio.
- 4) Olio ATF.
- 5) Rondella di tenuta.

L'olio può essere controllato sia a freddo che a caldo.

**NOTA:** Controllare sempre il livello dell'olio prima della messa in funzione dell'invertitore operando nel seguente modo.

- Allentare l'astina dell'olio (Fig. 11) girandola a mano in senso antiorario ed estrarla.
- Pulire l'astina con uno straccio pulito e senza polvere.
- Appoggiare l'astina senza avvitarla; rimuoverla e controllare che il livello dell'olio sia tra i segni di massimo e minimo (3-4 Fig. 11).
- Reinserrare l'astina e bloccarla ruotandola in senso orario.



#### ATTENZIONE

**Al momento dello spegnimento del motore l'olio presente nel circuito idraulico inizierà a fluire nella trasmissione; tale quantità dipende dal tipo di scambiatore e dal circuito idraulico usati per il raffreddamento. Dopo un certo periodo l'olio si sarà raccolto nell'invertitore e questo ne alzerà livello.**

**Non rimuovete l'eccesso di olio così misurato ma procedete come ai successivi punti.**

- Lasciate girare al minimo il motore con l'invertitore in posizione di folle fino a che scambiatore di calore e tubi del circuito idraulico si siano riempiti di olio.
- Spegnete il motore e subito controllate il livello dell'olio; se necessario rabboccate. Il livello del fluido deve essere compreso tra i segni di max e min presenti nell'astina (Fig. 11). Ripetere l'operazione dopo un breve periodo di funzionamento.

### 6.1.2 CAMBIO DELL'OLIO



#### ATTENZIONE

**Il primo cambio dell'olio deve essere effettuato dopo 25 ore di funzionamento.**

**I successivi cambi di olio devono essere effettuati almeno ogni 300 ore di funzionamento ed in ogni caso non deve passare più di un anno tra un cambio e l'altro.**



#### ATTENZIONE

**Il lubrificante esausto deve essere trattato come un rifiuto speciale che inquina l'ambiente: è quindi da smaltire in funzione della sua struttura differenziata.**

### 6.1.3 SVUOTAMENTO DELL'OLIO

Rimuovere il tappo (1 Fig. 12) e fare defluire l'olio dall'apposito foro situato nella parte inferiore della scatola.

### 6.1.4 RIEMPIMENTO CON OLIO ATF

Riempire con olio per cambi automatici

ATF rispettando le quantità di seguito indicate. Aggiungere la quantità che si ritiene necessaria per il riempimento dello scambiatore di calore e dei relativi tubi di raccordo.

ZF 4-1 M: .....	0,42 litri
ZF 5 M: .....	0,42 litri
ZF 6 M: .....	0,42 litri
ZF 10 M: .....	0,42 litri
ZF 12 M: .....	0,60 litri
ZF 15 M: .....	0,60 litri
ZF 15 MA: .....	0,56 litri
ZF 15 MIV: .....	1,00 litri
ZF 25 M: .....	0,75 litri
ZF 25 MA: .....	0,75 litri
ZF 30 M: .....min. 0,90 - max. 1,10 litri	

• Valido per inclinazione dell'albero inferiore a 20 gradi (15° per ZF MIV). Usare unicamente olio per cambi au-

tomatici come da specifiche indicate nella «Lista degli oli raccomandati» a pag.82.

**6.1.5 PROVA DI FUNZIONAMENTO**

- 1) Effettuare una prova di funzionamento dopo il cambio dell'olio.
- 2) Posizionare la leva di comando in posizione neutrale (N).  
Accendere il motore e lasciarlo girare al minimo per un breve periodo; in questo modo lo scambiatore di calore ed il circuito idraulico si riempiranno dell'olio della trasmissione.
- 3) Fermare il motore e controllare di nuovo il livello dell'olio. Se necessario rabboccare. L'olio in eccesso deve essere rimosso.

Il livello nell'astina dell'olio deve essere compreso tra i segni di MIN e MAX.

Il livello dell'olio va ricontrollato dopo un breve periodo di funzionamento.

**6.1.6 IMMAGAZZINAMENTO**

Se la trasmissione va immagazzinata per un lungo periodo di tempo, per esempio durante l'inverno, essa va completamente riempita di olio ATF attraverso l'astina di livello, in questo modo si previene il gruppo dalla corrosione.



**ATTENZIONE**

**Cambiare l'olio quando la trasmissione viene rimessa di nuovo in funzionamento.**

**7.1 Ricerca guasti**

Prima di tutto controllare se sono state completate le istruzioni indicate nei punti precedenti.

<b>ANOMALIA</b>	<b>POSSIBILE CAUSA</b>	<b>RIMEDIO</b>
<b>1. Alta temperatura dell'olio</b>	<ul style="list-style-type: none"> <li>- Livello dell'olio troppo alto</li> <li>- Livello dell'olio basso</li> <li>- Scambiatore di calore ostruito</li> <li>- Mancanza di acqua nel circuito</li> </ul>	<ul style="list-style-type: none"> <li>- rimuovere l'eccesso di olio</li> <li>- rabboccare</li> <li>- sostituire lo scambiatore e controllare il circuito dell'acqua</li> <li>- controllare il circuito e riparare la perdita.</li> </ul>
<b>2. Presenza di olio sulla scatola</b>	<ul style="list-style-type: none"> <li>- Viti allentate</li> <li>- Raccordi allentati</li> <li>- Asta dell'olio allentata</li> <li>- Livello dell'olio troppo alto durante il funzionamento</li> </ul>	<ul style="list-style-type: none"> <li>- serrare alla coppia raccomandata</li> <li>- serrare o sostituire</li> <li>- serrare o sostituire</li> <li>- aspirare fino al segno di max.</li> </ul>
<b>3. Innesto duro</b>	<ul style="list-style-type: none"> <li>- Blocco distributore</li> <li>- Telecomando</li> </ul>	<ul style="list-style-type: none"> <li>- consultare un centro di assistenza</li> <li>- regolazione</li> </ul>
<b>4. Innesto lento</b>	<ul style="list-style-type: none"> <li>- Blocco distributore</li> <li>- Telecomando</li> </ul>	<ul style="list-style-type: none"> <li>- consultare un centro di assistenza</li> <li>- regolazione</li> </ul>
<b>5. L'imbarcazione non si muove</b>	<ul style="list-style-type: none"> <li>- Blocco distributore</li> <li>- Posizione errata della leva di comando</li> <li>- Perdita dell'elica</li> <li>- Rottura dell'asse elica</li> <li>- Trasmissione mal funzionante</li> <li>- Motore mal funzionante</li> </ul>	<ul style="list-style-type: none"> <li>- consultare un centro di assistenza</li> <li>- regolazione</li> <li>- reinstallare</li> <li>- consultare un centro di assistenza</li> <li>- consultare un centro di assistenza</li> <li>- consultare un centro di assistenza</li> </ul>





## 8.1 Dati tecnici

### Technical Data for Pleasure Craft Duty

Based on engine power B to DIN 6270; shock factor

**K = 1.25 to be applied, if engine has 1 cylinder / K = 1.20 for 2 cylinders / K = 1.15 for 3 cylinders**

MODEL	RATIO		POWER / RPM		INPUT POWER CAPACITY						MAX RPM	WEIGHT		BELL HSGS. AND NOTES
	«A» Pos	«B»Pos	kW	hp	2800 rpm		3000 rpm		3600 rpm			kg	lb	
					kW	hp	kW	hp	kW	hp				
ZF 5 M	2.045	1.864	0.0066	0.0088	18	25	20	27	20	27	8.5	19	SAE 6, B/W Max input power 20 kW	
	2.722	2.150	0.0047	0.0063	13	18	14	19	17	23				5000

**K = 1.25 to be applied, if engine has 1 cylinder / K = 1.20 for 2 cylinders / K = 1.15 for 3 cylinders**

MODEL	RATIO		POWER / RPM		INPUT POWER CAPACITY						MAX RPM	WEIGHT		BELL HSGS. AND NOTES
	«A» Pos	«B»Pos	kW	hp	2800 rpm		3000 rpm		3600 rpm			kg	lb	
					kW	hp	kW	hp	kW	hp				
ZF 6 M	2.045	1.864	0.0066	0.0088	18	25	20	27	20	27	10.3	23	SAE 4, 5, 6, B/W Max input power 20 kW	
	2.722	2.150	0.0047	0.0063	13	18	14	19	17	23				5000

**K = 1.25 to be applied, if engine has 1 cylinder / K = 1.20 for 2 cylinders / K = 1.15 for 3 cylinders**

\*\* Max. 95 Nm (70 ft lb) admissible for main travelling direction with gear lever set to «B»

MODEL	RATIO		POWER / RPM		INPUT POWER CAPACITY						MAX RPM	WEIGHT		BELL HSGS. AND NOTES						
	«A» Pos	«B»Pos	kW	hp	2800 rpm		3000 rpm		3600 rpm			kg	lb							
					kW	hp	kW	hp	kW	hp										
ZF 10 M	1.482	1.864	0.0109	0.0146	30	41	33	44	38	51	10.3	23	SAE 4, 5, 6, B/W Max input power 38 kW. <b>Ratio 1.482 «B» Pos.</b> <b>max torque 95 Nm. Ratio 1.792 «B» Pos. max torque 95 Nm.</b>							
	1.792	1.864																		
	2.045	1.864												27	36	29	38	34	46	5000
	2.722	2.150												0.0095	0.0128	19	26	20	27	25

**K = 1.25 to be applied, if engine has 1 cylinder / K = 1.20 for 2 cylinders / K = 1.15 for 3 cylinders**

MODEL	RATIO		POWER / RPM		INPUT POWER CAPACITY						MAX RPM	WEIGHT		BELL HSGS. AND NOTES
	«A» Pos	«B»Pos	kW	hp	2800 rpm		3000 rpm		3600 rpm			kg	lb	
					kW	hp	kW	hp	kW	hp				
ZF 12 M	2.136	1.955	0.0131	0.0176	37	49	39	53	47	63	13	29	SAE 4, 5, 6, B/W, Yanmar JH Max input power 55 kW	
	2.632	1.955												31

**K = 1.25 to be applied, if engine has 1 cylinder / K = 1.20 for 2 cylinders / K = 1.15 for 3 cylinders**

\*\* Max. 120 Nm (88.5 ft lb) admissible for main travelling direction with gear lever set to «B»

MODEL	RATIO		POWER / RPM		INPUT POWER CAPACITY						MAX RPM	WEIGHT		BELL HSGS. AND NOTES
	«A» Pos	«B»Pos	kW	hp	3000 rpm		3600 rpm		3800 rpm			kg	lb	
					kW	hp	kW	hp	kW	hp				
ZF 15 M	1.556	1.955	0.0152	0.0204	46	61	55	73	55	74	13	29	SAE 4, 5, 6, B/W, Yanmar JH Max input power 55 kW. <b>Ratio 1.556 «B» Pos.</b> <b>max torque 120 Nm.</b> <b>Ratio 1.875 «B» Pos.</b> <b>max torque 120 Nm.</b>	
	1.875	1.955												

«A» POS = continuous running position (normally AHEAD).

«B» POS = reverse position.

B/W = Borg Warner adaptor.

Note = For all «M» (Mechanical) transmissions reduce power capacity by the following shock factors: 1 cylinder engine ÷ 1.25, 2 cylinder engine ÷ 1.20, 3 cylinder engine ÷ 1.15.



**K = 1.25 to be applied, if engine has 1 cylinder / K = 1.20 for 2 cylinders / K = 1.15 for 3 cylinders**

\*\* Max. 120 Nm (88.5 ft lb) admissible for main travelling direction with gear lever set to «B»

MODEL	RATIO		POWER / RPM		INPUT POWER CAPACITY						MAX RPM	WEIGHT		BELL HSGS. AND NOTES
	«A» Pos	«B»Pos	kW	hp	kW	hp	kW	hp	kW	hp		kg	lb	
					3000 rpm	3600 rpm	3800 rpm							
ZF 15 MA 8 degrees	1.875	1.955	0.0152	0.0204	46	61	55	73	55	74	13.5	30	SAE 4, 5, 6, B/W, Yanmar JH Max input power 55 kW. <b>Ratio 1.875 «B» Pos. max torque 120 Nm. Ratio 2.136 «B» Pos. max torque 120 Nm.</b>	
	2.136	1.955	0.0131	0.0176	39	53	47	63	50	67				
	2.632	1.955	0.0111	0.0149	33	45	40	54	42	57				

**K = 1.25 to be applied, if engine has 1 cylinder / K = 1.20 for 2 cylinders / K = 1.15 for 3 cylinders**

\* Max. 120 Nm (88.5 ft lb) admissible for main travelling direction with gear lever set to «B».

\*\* Max 45 kW for main travelling direction with gear lever set to «B».

MODEL	RATIO		POWER / RPM		INPUT POWER CAPACITY						MAX RPM	WEIGHT		BELL HSGS. AND NOTES
	«A» Pos	«B»Pos	kW	hp	kW	hp	kW	hp	kW	hp		kg	lb	
					3000 rpm	3600 rpm	3800 rpm							
ZF 15 MIV 8 degrees	2.134	2.224	0.0152	0.0204	46	61	55	73	55	74	21	47	SAE 4, 5, B/W, Yanmar JH Max input power 55 kW. <b>Ratio 2.134 «B» Pos. max torque 120 Nm.</b>	
	2.718	2.224	0.0111	0.0149	33	45	40	54	42	57				
	2.995	2.224												

**K = 1.25 to be applied, if engine has 1 cylinder - K = 1.20 for 2 cylinders - K = 1.15 for 3 cylinders**

\*\* Max. 230 Nm (170 ft lb) admissible for main travelling direction with gear lever set to «B»

MODEL	RATIO		POWER / RPM		INPUT POWER CAPACITY						MAX RPM	WEIGHT		BELL HSGS. AND NOTES
	«A» Pos	«B»Pos	kW	hp	kW	hp	kW	hp	kW	hp		kg	lb	
					3000 rpm	3600 rpm	3800 rpm							
ZF 25 M	1.880	2.095	0.0262	0.0351	79	105	80	107	80	107	18.5	41	SAE 4, 5, B/W, Yanmar JH Max input power 80 kW. <b>Ratio 1.880 «B» Pos. max torque 230 Nm.</b>	
	2.273	2.095	0.0216	0.0289	65	87	78	104	80	107				
	2.737	2.722	0.0177	0.0237	53	71	64	85	67	90				

**K = 1.25 to be applied, if engine has 1 cylinder / K = 1.20 for 2 cylinders / K = 1.15 for 3 cylinders**

\*\* Max. 169 Nm (125 ft lb) admissible for main travelling direction with gear lever set to «B»

MODEL	RATIO		POWER / RPM		INPUT POWER CAPACITY						MAX RPM	WEIGHT		BELL HSGS. AND NOTES
	«A» Pos	«B»Pos	kW	hp	kW	hp	kW	hp	kW	hp		kg	lb	
					3000 rpm	3600 rpm	3800 rpm							
ZF 25 MA 8 degrees	2.227	2.737	0.0215	0.0288	64	86	77	104	80	107	21.1	47	SAE 4, 5, B/W, Yanmar JH Max input power 80 kW. <b>Ratio 2.227 «B» Pos. max torque 169 Nm.</b>	
	2.737	2.737	0.0177	0.0237	53	71	64	85	67	90				

**K = 1.25 to be applied, if engine has 1 cylinder / K = 1.20 for 2 cylinders / K = 1.15 for 3 cylinders**

\*\* Max. 185 Nm (137 ft lb) admissible for main travelling direction with gear lever set to «B»

MODEL	RATIO		POWER / RPM		INPUT POWER CAPACITY						MAX RPM	WEIGHT		BELL HSGS. AND NOTES
	«A» Pos	«B»Pos	kW	hp	kW	hp	kW	hp	kW	hp		kg	lb	
					3000 rpm	3600 rpm	3800 rpm							
ZF 30 M	2.148	2.636	0.0241	0.0323	72	97	87	116	92	123	23	51	4 & 5 Yanmar JH Max input power 95 kW. <b>Ratio 2.148 «B» Pos. max torque 185 Nm. Ratio 2.696 «B» Pos. max torque 185 Nm.</b>	
	2.696	2.636												

«A» POS = continuous running position (normally AHEAD).

«B» POS = reverse position.

B/W = Borg Warner adaptor.

Note = For all «M» (Mechanical) transmissions reduce power capacity by the following shock factors: 1 cylinder engine ÷ 1.25, 2 cylinder engine ÷ 1.20, 3 cylinder engine ÷ 1.15.

## 9.1 Garanzia

### 9.1.1 CONDIZIONI DI GARANZIA

La ZF Marine Arco S.p.A. garantisce i suoi invertitori serie ZFM da qualsiasi difetto nei materiali e/o manodopera, per un utilizzo in condizioni normali e nel caso sia effettuata una corretta manutenzione.

Questa garanzia è valida solo nel caso che l'installazione sia stata eseguita correttamente e che la trasmissione sia stata utilizzata in modo corretto.

L'obbligo della ZF Marine Arco S.p.A. sotto questa garanzia è limitato alla sostituzione o alla riparazione, a sua scelta, della parte o delle parti riconosciute difettose dalla ZF Marine Arco S.p.A. dopo suo esame delle stesse, a condizione che la parte o le parti siano ritornate al più vicino ZF Marine Arco S.p.A. dealer ufficiale, spese di trasporto pagate in anticipo, entro il termine di: Ventiquattro (24) mesi dalla data di installazione o trentasei (36) mesi dalla data di spedizione al costruttore di motori, è valida la condizione che scade per prima.

Gli obblighi della ZF Marine Arco S.p.A. sotto questa garanzia, come qui specificato, sono inoltre soggetti al rispetto da parte del distributore o del costruttore di motori che ha commercializzato il prodotto, delle Procedure di Garanzia che sono parte integrante di questa garanzia.

Tutte le richieste di garanzia dovranno essere presentate al distributore o costruttore di motori che ha commercializzato la trasmissione ZF.

Questa garanzia non è valida nel caso che una o più parti siano state riparate o modificate senza il precedente consenso scritto di un dealer ufficiale ZF Marine Arco S.p.A. Questa garanzia non è valida se il prodotto o i suoi componenti o parti siano stati soggetti a cattivo uso, negligenza, alterazione o incidenti o non hanno funzionato secondo le istruzioni scritte della ZF Marine Arco S.p.A. o hanno funzionato in condizioni più gravose o in ogni modo eccedenti quelle specificate per il detto prodotto, o sono stati installati e fatti funzionare in maniera non corretta.

Questa garanzia sostituisce tutte le altre garanzie esplicite o implicite che comprendono le garanzie di commercializzazione e di buon uso ed eventuali altri obblighi che comprendono danni da utilizzo del prodotto.

La ZF Marine Arco S.p.A. non è responsabile né autorizza altre persone ad assumersi altre responsabilità collegate con la vendita dell'invertitore ZFM.

La ZF Marine Arco S.p.A. non è in ogni caso responsabile per danni che superino il prezzo di commercio dell'invertitore ZFM.

### 9.1.2 RESPONSABILITÀ TORSIONALE E GIUNTI TORSIONALI

La responsabilità di assicurare la compatibilità torsionale compete al montatore dell'azionamento e dell'apparecchiatura azionata.

ZF Marine Arco S.p.A. non si assume alcuna responsabilità per i rumori del cambio causati da vibrazioni o per i danni causati da questo tipo di vibrazioni al cambio, al giunto flessibile o ad altre parti del gruppo di azionamento. Contattare ZF Marine Arco S.p.A. per ulteriori informazioni e assistenza.

ZF Marine Arco S.p.A. raccomanda l'impiego di un limitatore torsionale per le imbarcazioni a un solo motore, nelle quali la perdita di propulsione può determinare la perdita di controllo. È responsabilità del compratore specificare questa opzione, che può comportare un maggior costo e un possibile aumento della lunghezza d'installazione.

ZF Marine Arco S.p.A. non si assume alcuna responsabilità per lesioni personali, anche mortali, o per danni o perdita di cose causati da mancata specificazione da parte del compratore di un limitatore torsionale.

ZF Marine Arco S.p.A. sceglie i giunti torsionali sulla base della coppia nominale in entrata e delle velocità nominali di regime del motore generalmente accettate.

Consultare ZF Marine Arco S.p.A. per dettagli sui limiti di velocità dei giunti torsionali dell'offerta standard, che possono essere inferiori al limite della trasmissione.

Si possono richiedere giunti torsionali speciali per i requisiti della classificazione Survey Society Ice.

# ENGLISH

## Section

1.1	Introduction.....	12
2.1	Gear Identification.....	12
3.1	Description.....	12
4.1	Installation.....	12
5.1	Operation.....	13
6.1	Maintenance.....	14
7.1	Troubleshooting.....	15
8.1	Technical Data.....	16
9.1	Warranty.....	18
10.1	List of recommended fluids.....	82
11.1	Dealer List.....	83
12.1	Installation layout.....	84
13.1	Warranty Card.....	95

## 1.1 Introduction

### 1.1.1 CUSTOMER'S RESPONSIBILITY

The Customer/Operator is responsible to perform the necessary safety checks to ensure that lubrication, cooling, maintenance and recommended practices are strictly followed for safe, enjoyable operation.

All Transmission units are covered by a guarantee. Therefore: In respect to the handling of the transmission units the instructions stated in this manual are to be strictly followed.



#### CAUTION

**The manufacturer is not liable for any damages or losses caused by faulty installation, wrong handling of the equipment and/or deficient maintenance.**

**The Customer has to make sure, that any external forces, as well as vibration caused by torsion and bending, are avoided.**

**The interaction between engine, shaft and propeller may lead to torsional vibration, producing a hammering noise of gears and might damage the engine and/or transmission.**

**The Supplier is not liable for such torsional vibration inherent to the installation.**

This manual includes, among others, the following three main chapters:

### 1.1.2 DESCRIPTION

This part briefly describes function, operation and design of the ZF M.

### 1.1.3 OPERATION

This part describes the procedures for Operation and all necessary safety measures.

### 1.1.4 MAINTENANCE

This part contains all maintenance and service tasks to be performed by the operator.

Whenever the terms "right, left, starboard, port" are used in this manual, they always refer to the installed transmission in direction of forward movement.

Important information related to technical reliability and operational safety are highlighted by the identifying words as follows:



#### WARNING

**Any procedure, practice, condition, statement etc., which is not strictly followed, could result in injury or death of personnel.**



#### CAUTION

**Any procedure, practice, condition, statement etc., which is not strictly followed, could result in damage or destruction of equipment.**

**NOTE:** Applies to technical requirement to which the user of the equipment must pay particular attention.

**WARNING, CAUTION and NOTE** always precede the text to which they apply.

## 2.1 Gear Identification

The identification plate is affixed to the reverser.

An example of an identification plate is shown in Fig. 1:

- A** Transmission Serial Number.
- B** Transmission part number.
- C** Transmission ratio propeller rotation same as engine rotation.

**D** Transmission ratio propeller rotation opposite to a engine rotation.

**E** Every year a new progressive letter is assigned.

**F** Transmission Type.

Significance of transmission designations:

**G** Transmission Type.

**H** Size of transmission

**I** Version of transmission

## 3.1 Description

ZF M boat reversing gearbox units are automatically controlled helical gear transmissions.

They are of sturdy construction and utmost reliability. Nevertheless the user should make a point of observing the following instructions for installation, operation and maintenance.

Failure to do so, or unauthorized changes in the transmission, will preclude all and any warranty claims.

A Service Manual is available from the manufacturer.

Fig. 2:

- 1) Exchanger
- 2) Output flange
- 3) Identification plate
- 4) Control lever
- 5) Remote control bracket
- 6) Bowl
- 7) Input shaft
- 8) Oil level dipstick

## 4.1 Installation

When mounting the ZF M transmissions, the following items should be specially noted:

- Mounting should be done by a specialist only.
- Arrange the transmission and engine correctly.
- **INCLINED POSITION** (Fig. 3): In relation to the input shaft, the position of the transmission must slant no more than 20° (15° for ZF MIV) in the continuous service mode. Permissible lateral inclination obtainable from manufacturer on inquiry.
- **COUPLINGS:** Torsionally elastic coupling with min 0.5 mm (0.02") radial clearance, required on engine

side; flexible elastic coupling recommended on propeller side.

• **ENGINE-TRANSMISSION CONNECTION** (Fig. 4):

- 1) Engine flange
  - 2) Flywheel
  - 3) Coupling
  - 4) Transmission shaft
  - 5) Transmission flange
  - 6) Flywheel housing
- Max radial and face runout  
X: B- 0.1 mm

• **TRANSMISSIBLE-PROPELLER SHAFT CONNECTION** (Fig. 5 - 6):

- Choose adequate cooler.

For detail information see Installation on Manual.

**Type of fluid:** ATF (Automatic Transmission Fluid); see chapter 10.1.

## 5.1 Operation

All transmissions have been submitted to a test run before shipment:

During normal operation, the transmission should only be shifted with the engine at idle speed.

In emergency cases it is also admissible to shift at higher speeds.

The hydraulic circuit will only operate correctly if the hydraulic fluid is changed regularly, as indicated in the maintenance schedule. (See chapter 6.1).

Visual checks for leakage should be made from time to time.



**WARNING**

**Work on the transmission must only be performed with the engine and propeller at standstill.**



**CAUTION**

**Before the first start-up, the transmission must be filled with transmission fluid. For filling procedure, fluid type, quantity and level refer to chapter 6.1.4 fluid change.**



**CAUTION**

**Using the transmission with an insufficient oil level will damage the gears. An excessive oil level may cause leakage at the shaft seals**

**and the transmission breather, and raise the operating temperature considerably.**

### 5.1.1 OPERATION PROCEDURE



**CAUTION**

**Before operating the transmission, check fluid level (see chapter 6.1.1).**



**CAUTION**

**During normal operation, the transmission should only be shifted with the engine at idle speed. Shifting at higher engine speed may lead to overstress of the friction disks of the coupling and should be avoided in normal operation.**

**NOTE:** The transmission may be shifted from forward to reverse in case of emergency, even at high engine speed.

#### SHIFTING POSITIONS (figure 7):

A = Propeller rotation opposite of engine rotation

N = Neutral position

B = Propeller rotation same as engine rotation



**WARNING**

**Start engine with transmission in neutral only.**

Normal operating temperature of the transmission oil should be in the range of 50°C (122°F) to 80°C (176°F).

Max. permissible ATF temperature of 100°C (212°F) may only be reached for a short time.



**CAUTION**

**If the fluid temperature is too high, stop engine immediately and check transmission fluid level and oil cooler for proper water flow.**

**Do not start the engine again until the malfunction is eliminated.**

### 5.1.2 SAILING, TUGGED OR ANCHORED

The propeller may turn owing to the effect of the current when the engine is off and the craft is sailing, or when it is tugged or anchored. This represents no danger for the transmission. In a boat with two engines, the propeller of the unused transmission may idle freely. When the engine is off, the position of the shifting lever is irrelevant.



**CAUTION**

**Idling position of the propeller: gear shift lever must be in «N» (Fig.7) position. Use the shift position opposite to the direction of travel for locking the propeller shaft, otherwise the transmission will be damaged.**



**WARNING**

**Do not work on the transmission when being towed, or anchoring in a river because the propeller may rotate.**



**WARNING**

**Do not work on the transmission in a twin engine boat, when one unit is under power. The propeller shaft of the inoperative transmission will rotate.**



**WARNING**

**When the engine runs idle, but the propeller shaft should not be driven (such as when charging the battery with the generator), the shifting lever (figure 7) must be held in the neutral position (N) to prevent the boat from moving.**

**Avoid to run the hydraulic gearbox in neutral at high engine speed for a long time.**

### 5.1.3 CONTROL SYSTEM



**CAUTION**

**Make certain that control rod or cable is easily movable.**



**LEVER TRAVEL:**

Mod: **ZF 5 M - 6 M - 10 M-- 10 M- 12 M - 15 M - 15 MA - 15 MIV - 25 M - 25 MA - 30 M.**

Minimum travel of gear shift lever (N-A=N-B) must be 35 mm (1.3/8") for outer pivot point and 30 mm (1.3/16") for inner pivot point.

**Fig. 8:**

- 1) Clamping screw torque  
22 ± 1 Nm (17 lbf ft)
- 2) Minimum lever travel for control cable
- 3) Do **not** open cover
- 4) Oil drain plug  
Driving torque: Ma=22 Nm (16 lb-ft).

**LEVER TRAVEL:**

Mod: **ZF 4-1 M**

Travel of gear shift lever (N-A=N-B) must be 38,5±1,5 mm (1.52 in ± 0.06 in) for outer pivot point and 33,5±1,5 mm, (1.32 in ± 0.06 in) for inner pivot point, from neutral position.

When the lever pass over the angle of 10°-12°, it starts to move outside perpendicular and stops when the travel is completed (angle of 40°).

**Fig. 9:**

- 1) Clamping screw torque  
22 ± 1 Nm (17 lbf ft)
- 2) Do not unscrew the nut
- 3) Do **not** open cover

**LEVER POSITION:** In neutral position perpendicular to control rod or cable. Gear shift lever can be fixed in any position by means of clamping screw. Minimum distance between gear shift lever and cover 0.5 mm (0.02"). Opening or loosening of cover requires renewed adjustment (by specialized personnel only).

**Fig. 10:**

- 1) Oil dipstick and filler screw, 17 mm  
Driving torque: Ma = 20 Nm (15 lb-ft).
- 2) Control lever clearance min 0.5 mm

**INSPECTIONS:** Frequently check the position of the lever to make sure that everything operates correctly.

## 6.1 Maintenance

### 6.1.1 FLUID LEVEL CHECK

**WARNING**

**Do not work on the transmission when being towed, or anchoring in a river because the propeller may rotate.**

#### DESCRIPTION OF THE DIPSTICK (Fig. 11):

- 1) Housing surface
- 2) Dipstick
- 3) ATF level
- 4) ATF
- 5) Retention washer

Transmission fluid level may be checked in cold or hot condition.

**NOTE:** Always check the oil level before operating the reverser. Proceed as described below.

- Loosen fluid dipstick (figure 11) by turning the grip counterclockwise.
- Wipe dipstick with a clean and dust-free cloth.
- Insert dipstick do not screw in (3-4 figure 11). Remove dipstick and check fluid level: Fluid level has to be between minimum and maximum marks.
- Insert the dipstick and lock it by turning the grip clockwise.

**CAUTION**

**According to the type and arrangement of the cooler and pipelines a certain amount of oil will collect after stopping the engine and will flow back into the transmission after a longer rest period. This may cause the oil level in the transmission to exceed the max. mark. Do not remove off the surplus oil but proceed according to steps.**

- Let engine run at idle speed with shifting lever in neutral position until fluid cooler and all pipelines are filled with fluid.

- Switch off engine and check fluid level within a short time. If necessary, top fluid level off to the dipstick mark.

The fluid level on the dipstick (figure 11) should be between the min. and max. marks. The fluid level must be checked again after a short driving period.

### 6.1.2 FLUID CHANGE

**CAUTION**

**The first change must be performed after 25 hours of operation. All subsequent fluid changes to be made after every 300 hours of operation or once in a year (according to the term which is reached earlier).**

**CAUTION**

**Used lubricant must be treated as special waste that pollutes the environment: it must therefore be disposed of in accordance with its particular structure.**

### 6.1.3 DRAINING TRANSMISSION FLUID

Remove the plug (1 Fig. 12) and allow the oil to drain through the hole in the lower part of the housing.

### 6.1.4 FILLING UP WITH TRANSMISSION FLUID

Fill with ATF oil for automatic gearboxes according to the indicated quantities. Add the quantity considered necessary for filling the heat exchanger and relative connection pipes.

ZF 4-1 M: ... 0,42 liters (0,45 US-qts)  
 ZF 5 M: ..... 0,42 liters (0,45 US-qts)  
 ZF 6 M: ..... 0,42 liters (0,45 US-qts)  
 ZF 10 M: ..... 0,42 liters (0,45 US-qts)  
 ZF 12 M: ..... 0,60 liters (0,64 US-qts)  
 ZF 15 M: ..... 0,60 liters (0,64 US-qts)  
 ZF 15 MA: ... 0,56 liters (0,60 US-qts)  
 ZF 15 MIV: .. 1,00 liters (1,06 US-qts)  
 ZF 25 M: ..... 0,75 liters (0,80 US-qts)  
 ZF 25 MA: ... 0,75 liters (0,80 US-qts)  
 ZF 30 M: min. 0,90 liters (0,95 US-qts)  
 max. 1,10 liters (1,17 US-qts)

- Valid for shafts tilting less than 20 degrees (15° for ZF MIV).



Only use oil for automatic gearboxes, as given in the specification in the «List of recommended oils» on page 82.

### 6.1.5 TRIAL RUN

- 1) Carry out a trial run after the oil change.
- 2) Set shifting lever to neutral position (N). Start engine and let it run idle for a short time to fill the cooler and pipelines with transmission oil.

- 3) Stop the engine and check oil level again.  
If necessary, replenish with oil. Excessive oil should be removed. The fluid level on the dipstick should be between the min. and max. marks.  
The fluid level should be checked again after a short driving period.

### 6.1.6 STORAGE

If the transmission is stored for longer time, for example winter storage, it should be topped off through the dipstick hole with ATF to prevent the unit from corrosion.



#### CAUTION

**Change the fluid when putting the unit into operation again.**

## 7.1 Troubleshooting

First of all check, whether all items of operating instructions have been complied with.

SYMPTOM	POSSIBLY CAUSED BY	REMEDY
<b>1. High fluid temperature</b>	<ul style="list-style-type: none"> <li>- Fluid level high during operation</li> <li>- Fluid level low</li> <li>- Plugged or restricted</li> <li>- No water in cooling system</li> </ul>	<ul style="list-style-type: none"> <li>- Pump out fluid to max. mark on dipstick</li> <li>- Add fluid</li> <li>- Replace cooler and flush fluid cooler water system</li> <li>- Check cooling system and repair</li> </ul>
<b>2. Fluid on transmission housing</b>	<ul style="list-style-type: none"> <li>- Loose screws</li> <li>- Loose screw connections</li> <li>- Loose dipstick</li> <li>- Fluid level high during operation</li> </ul>	<ul style="list-style-type: none"> <li>- Tighten to specification</li> <li>- Tighten, replace</li> <li>- Tighten, replace</li> <li>- Pump out fluid to max. mark on dipstick</li> </ul>
<b>3. Shifts hard</b>	<ul style="list-style-type: none"> <li>- Selector control</li> <li>- Unknown</li> </ul>	<ul style="list-style-type: none"> <li>- Consult service station</li> <li>- Consult service station</li> </ul>
<b>4. Slow engagement</b>	<ul style="list-style-type: none"> <li>- Selector control</li> <li>- Unknown</li> </ul>	<ul style="list-style-type: none"> <li>- Consult service station</li> <li>- Consult service station</li> </ul>
<b>5. No movement of the boat</b>	<ul style="list-style-type: none"> <li>- Selector control</li> <li>- Improper selector position</li> <li>- Propeller missing</li> <li>- Propeller shaft broken</li> <li>- Transmission malfunction</li> <li>- Engine malfunction</li> </ul>	<ul style="list-style-type: none"> <li>- Consult service station</li> <li>- Adjust</li> <li>- Replace</li> <li>- Consult service station</li> <li>- Consult service station</li> <li>- Consult service station</li> </ul>



## 8.1 Technical Data

### Technical Data for Pleasure Craft Duty

Based on engine power B to DIN 6270; shock factor

**K = 1.25 to be applied, if engine has 1 cylinder / K = 1.20 for 2 cylinders / K = 1.15 for 3 cylinders**

MODEL	RATIO		POWER / RPM		INPUT POWER CAPACITY						MAX RPM	WEIGHT		BELL HSGS. AND NOTES
	«A» Pos	«B»Pos	kW	hp	2800 rpm		3000 rpm		3600 rpm			kg	lb	
					kW	hp	kW	hp	kW	hp				
ZF 5 M	2.045	1.864	0.0066	0.0088	18	25	20	27	20	27	8.5	19	SAE 6, B/W Max input power 20 kW	
	2.722	2.150	0.0047	0.0063	13	18	14	19	17	23				5000

**K = 1.25 to be applied, if engine has 1 cylinder / K = 1.20 for 2 cylinders / K = 1.15 for 3 cylinders**

MODEL	RATIO		POWER / RPM		INPUT POWER CAPACITY						MAX RPM	WEIGHT		BELL HSGS. AND NOTES
	«A» Pos	«B»Pos	kW	hp	2800 rpm		3000 rpm		3600 rpm			kg	lb	
					kW	hp	kW	hp	kW	hp				
ZF 6 M	2.045	1.864	0.0066	0.0088	18	25	20	27	20	27	10.3	23	SAE 4, 5, 6, B/W Max input power 20 kW	
	2.722	2.150	0.0047	0.0063	13	18	14	19	17	23				5000

**K = 1.25 to be applied, if engine has 1 cylinder / K = 1.20 for 2 cylinders / K = 1.15 for 3 cylinders**

\*\* Max. 95 Nm (70 ft lb) admissible for main travelling direction with gear lever set to «B»

MODEL	RATIO		POWER / RPM		INPUT POWER CAPACITY						MAX RPM	WEIGHT		BELL HSGS. AND NOTES						
	«A» Pos	«B»Pos	kW	hp	2800 rpm		3000 rpm		3600 rpm			kg	lb							
					kW	hp	kW	hp	kW	hp										
ZF 10 M	1.482	1.864	0.0109	0.0146	30	41	33	44	38	51	10.3	23	SAE 4, 5, 6, B/W Max input power 38 kW. <b>Ratio 1.482 «B» Pos. max torque 95 Nm. Ratio 1.792 «B» Pos. max torque 95 Nm.</b>							
	1.792	1.864																		
	2.045	1.864												27	36	29	38	34	46	5000
	2.722	2.150												0.0068	0.0091	19	26	20	27	25

**K = 1.25 to be applied, if engine has 1 cylinder / K = 1.20 for 2 cylinders / K = 1.15 for 3 cylinders**

MODEL	RATIO		POWER / RPM		INPUT POWER CAPACITY						MAX RPM	WEIGHT		BELL HSGS. AND NOTES
	«A» Pos	«B»Pos	kW	hp	2800 rpm		3000 rpm		3600 rpm			kg	lb	
					kW	hp	kW	hp	kW	hp				
ZF 12 M	2.136	1.955	0.0131	0.0176	37	49	39	53	47	63	13	29	SAE 4, 5, 6, B/W, Yanmar JH Max input power 55 kW	
	2.632	1.955	0.0111	0.0149	31	42	33	45	40	54				5000

**K = 1.25 to be applied, if engine has 1 cylinder / K = 1.20 for 2 cylinders / K = 1.15 for 3 cylinders**

\*\* Max. 120 Nm (88.5 ft lb) admissible for main travelling direction with gear lever set to «B»

MODEL	RATIO		POWER / RPM		INPUT POWER CAPACITY						MAX RPM	WEIGHT		BELL HSGS. AND NOTES
	«A» Pos	«B»Pos	kW	hp	3000 rpm		3600 rpm		3800 rpm			kg	lb	
					kW	hp	kW	hp	kW	hp				
ZF 15 M	1.556	1.955	0.0152	0.0204	46	61	55	73	55	74	13	29	SAE 4, 5, 6, B/W, Yanmar JH Max input power 55 kW. <b>Ratio 1.556 «B» Pos. max torque 120 Nm. Ratio 1.875 «B» Pos. max torque 120 Nm.</b>	
	1.875	1.955												

«A» POS = continuous running position (normally AHEAD).

«B» POS = reverse position.

B/W = Borg Warner adaptor.

Note = For all «M» (Mechanical) transmissions reduce power capacity by the following shock factors: 1 cylinder engine ÷ 1.25, 2 cylinder engine ÷ 1.20, 3 cylinder engine ÷ 1.15.



**K = 1.25 to be applied, if engine has 1 cylinder / K = 1.20 for 2 cylinders / K = 1.15 for 3 cylinders**

\*\* Max. 120 Nm (88.5 ft lb) admissible for main travelling direction with gear lever set to «B»

MODEL	RATIO		POWER / RPM		INPUT POWER CAPACITY						MAX RPM	WEIGHT		BELL HSGS. AND NOTES
	«A» Pos	«B»Pos	kW	hp	3000 rpm		3600 rpm		3800 rpm			kg	lb	
					kW	hp	kW	hp	kW	hp				
ZF 15 MA 8 degrees	1.875	1.955	0.0152	0.0204	46	61	55	73	55	74	5000	13.5	30	SAE 4, 5, 6, B/W, Yanmar JH Max input power 55 kW. <b>Ratio 1.875 «B» Pos. max torque 120 Nm. Ratio 2.136 «B» Pos. max torque 120 Nm.</b>
	2.136	1.955	0.0131	0.0176	39	53	47	63	50	67				
	2.632	1.955	0.0111	0.0149	33	45	40	54	42	57				

**K = 1.25 to be applied, if engine has 1 cylinder / K = 1.20 for 2 cylinders / K = 1.15 for 3 cylinders**

\* Max. 120 Nm (88.5 ft lb) admissible for main travelling direction with gear lever set to «B».

\*\* Max 45 kW for main travelling direction with gear lever set to «B».

MODEL	RATIO		POWER / RPM		INPUT POWER CAPACITY						MAX RPM	WEIGHT		BELL HSGS. AND NOTES
	«A» Pos	«B»Pos	kW	hp	3000 rpm		3600 rpm		3800 rpm			kg	lb	
					kW	hp	kW	hp	kW	hp				
ZF 15 MIV 8 degrees	2.134	2.224	0.0152	0.0204	46	61	55	73	55	74	5000	21	47	SAE 4, 5, B/W, Yanmar JH Max input power 55 kW. <b>Ratio 2.134 «B» Pos. max torque 120 Nm.</b>
	2.718	2.224	0.0111	0.0149	33	45	40	54	42	57				
	2.995	2.224												

**K = 1.25 to be applied, if engine has 1 cylinder - K = 1.20 for 2 cylinders - K = 1.15 for 3 cylinders**

\*\* Max. 230 Nm (170 ft lb) admissible for main travelling direction with gear lever set to «B»

MODEL	RATIO		POWER / RPM		INPUT POWER CAPACITY						MAX RPM	WEIGHT		BELL HSGS. AND NOTES
	«A» Pos	«B»Pos	kW	hp	3000 rpm		3600 rpm		3800 rpm			kg	lb	
					kW	hp	kW	hp	kW	hp				
ZF 25 M	1.880	2.095	0.0262	0.0351	79	105	80	107	80	107	5000	18.5	41	SAE 4, 5, B/W, Yanmar JH Max input power 80 kW. <b>Ratio 1.880 «B» Pos. max torque 230 Nm.</b>
	2.273	2.095	0.0216	0.0289	65	87	78	104	80	107				
	2.737	2.722	0.0177	0.0237	53	71	64	85	67	90				

**K = 1.25 to be applied, if engine has 1 cylinder / K = 1.20 for 2 cylinders / K = 1.15 for 3 cylinders**

\*\* Max. 169 Nm (125 ft lb) admissible for main travelling direction with gear lever set to «B»

MODEL	RATIO		POWER / RPM		INPUT POWER CAPACITY						MAX RPM	WEIGHT		BELL HSGS. AND NOTES
	«A» Pos	«B»Pos	kW	hp	3000 rpm		3600 rpm		3800 rpm			kg	lb	
					kW	hp	kW	hp	kW	hp				
ZF 25 MA 8 degrees	2.227	2.737	0.0215	0.0288	64	86	77	104	80	107	5000	21.1	47	SAE 4, 5, B/W, Yanmar JH Max input power 80 kW. <b>Ratio 2.227 «B» Pos. max torque 169 Nm.</b>
	2.737	2.737	0.0177	0.0237	53	71	64	85	67	90				

**K = 1.25 to be applied, if engine has 1 cylinder / K = 1.20 for 2 cylinders / K = 1.15 for 3 cylinders**

\*\* Max. 185 Nm (137 ft lb) admissible for main travelling direction with gear lever set to «B»

MODEL	RATIO		POWER / RPM		INPUT POWER CAPACITY						MAX RPM	WEIGHT		BELL HSGS. AND NOTES
	«A» Pos	«B»Pos	kW	hp	3000 rpm		3600 rpm		3800 rpm			kg	lb	
					kW	hp	kW	hp	kW	hp				
ZF 30 M	2.148	2.636	0.0241	0.0323	72	97	87	116	92	123	5000	23	51	4 & 5 Yanmar JH Max input power 95 kW. <b>Ratio 2.148 «B» Pos. max torque 185 Nm. Ratio 2.696 «B» Pos. max torque 185 Nm.</b>
	2.696	2.636												

«A» POS = continuous running position (normally AHEAD).

«B» POS = reverse position.

B/W = Borg Warner adaptor.

Note = For all «M» (Mechanical) transmissions reduce power capacity by the following shock factors: 1 cylinder engine ÷ 1.25, 2 cylinder engine ÷ 1.20, 3 cylinder engine ÷ 1.15.

## 9.1 Warranty

### 9.1.1 STANDARD WARRANTY

ZF Marine Arco S.p.A. warrants its type ZFM Reversing Marine Transmission to be free from defects in material and work-manship under normal use and maintenance, provided that this warranty shall apply if, and only if, the equipment has been properly installed and operated.

The obligation of ZF Marine Arco S.p.A. under this warranty shall be limited to the replacement or repair, at its choice, of any part or parts found to be defective by ZF Marine Arco S.p.A. upon its examination of same, provided that the part or parts are returned to the nearest official ZF Marine Arco S.p.A. distributor, freight prepaid, within the time:

Twenty-four (24) months from date of commissioning or thirty-six (36) months from date of delivery to engine manufacturer, whichever occurs first.

The obligations of ZF Marine Arco S.p.A. under this warranty as set forth herein shall also be subject to compliance by the distributor or engine manufacturer who has purchased the product with the Warranty Procedures which is made a part of this warranty. All warranties shall run to distributors and engine manufacturers who have purchased the type ZF Reversing Ma-

rine Transmission. This warranty shall not apply to any part or parts which have been repaired or altered, without the prior written consent of an official ZF Marine Arco S.p.A. dealer.

This warranty shall not apply if the product or any of its components or parts have been subject to misuse, abuse, negligence, alteration, or accident, or have not been operated in accordance with printed instructions of ZF Marine Arco S.p.A. or has been operated under conditions more severe than, or otherwise exceeding, those set forth in the specifications for said product, or has been improperly installed or reinstalled, or improperly maintained and operated.

This warranty is expressly in lieu of all other warranties expresses or implied including the warranties of merchantability and fitness for use and of all other obligations including without limitation, consequential damages, and ZF Marine Arco S.p.A. neither assumes nor authorizes any other person to assume for ZF Marine Arco S.p.A., any other liability in connection with the sale of the ZFM Reversing Marine Transmission.

ZF Marine Arco S.p.A. shall in no event be liable for any breach of warranty in an amount exceeding the purchase price of the ZFM Reversing Marine Transmission.

### 9.1.2 TORSIONAL RESPONSIBILITY AND TORSIONAL COUPLINGS

The responsibility for ensuring torsional compatibility rests with the assembler of the drive and driven equipment.

ZF Marine Arco S.p.A. can accept no liability for gearbox noise caused by vibrations or for damage to the gearbox, the flexible coupling or to other parts of the drive unit caused by this kind of vibration.

Contact ZF Marine Arco S.p.A. for further information and assistance.

ZF Marine Arco S.p.A. recommends the use of a torsional limit stop for single engine powered boats, wherein loss of propulsion power can result in loss of control. It is the buyer's responsibility to specify this option, which can result in additional cost and a possible increase in installation length.

ZF Marine Arco S.p.A. can accept no liability for personal injury, loss of life, or damage or loss of property due to the failure of the buyer to specify, a torsional limit stop.

ZF Marine Arco S.p.A. selects torsional couplings on the basis of nominal input torque ratings and commonly accepted rated engine governed speeds.

Consult ZF Marine Arco S.p.A. for details concerning speed limits of standard offering torsional couplings, which can be less than the transmission limit. Special torsional couplings may be required for Survey Society Ice Classification requirements.



## DEUTSCH

### Kapitel

1.1	Vorwort .....	19
2.1	Getriebe-Identifizierung .....	19
3.1	Beschreibung .....	19
4.1	Installation .....	19
5.1	Bedienung .....	20
6.1	Wartung .....	21
7.1	Fehlersuche .....	22
8.1	Technische Daten .....	23
9.1	Garantie .....	25
10.1	Öle empfehlungsliste .....	82
11.1	Händlerliste .....	83
12.1	Installationzeichnungen .....	84
13.1	Warranty Card .....	95

## 1.1 Vorwort

### 1.1.1 VERANTWORTUNG DES EIGENTÜMERS

Es liegt in der Verantwortung des Eigentümers und des Benutzers, die notwendigen Sicherheitsüberprüfungen durchzuführen und sicherzustellen, daß alle Schmier- und Kühlmittel in ausreichendem Maße vorhanden sind und die Wartung nach den vorgeschriebenen Richtlinien erfolgt.



#### ACHTUNG

**Der Hersteller haftet nicht für fehlerhafte Installation, nicht sachgemäße Behandlung und unzureichende Wartung.**

**Der Betreiber sollte sicherstellen, daß externe Kräfteinwirkung durch Dreh- oder Biegeeffekte vermieden wird, da dies Vibrationen erzeugt.**

**Die Wechselwirkung zwischen Motor, Welle und Propeller kann zu Drehschwingungen führen, die hammerschlagartige Geräusche verursachen und unter Umständen zu Schäden an Motor und Getriebe führen.**

**ZF Marine Arco S.p.A. ist nicht haftbar für solche, der Installation anhaftenden Drehschwingungen.**

Dieses Handbuch beinhaltet unter anderem die folgenden drei Hauptkapitel:

### 1.1.2 BESCHREIBUNG

Dieser Teil beschreibt in kurzer Form die Funktion und Handhabung sowie die Konstruktion des ZF M.

### 1.1.3 BEDIENUNG

Dieser Teil beschreibt die Bedienung sowie die notwendigen Sicherheitsmaßnahmen.

### 1.1.4 WARTUNG

Dieser Teil beinhaltet alle Reparatur- und Wartungsaufgaben, die der Betreiber durchzuführen hat.

Die in diesem Handbuch benutzten Begriffe "Steuerbord, Backbord, links, rechts" beziehen sich immer auf das installierte Getriebe in Vorwärtsrichtung.

Wichtige Informationen in Bezug auf technische Zuverlässigkeit und Betriebssicherheit werden hervorgehoben durch die folgenden Begriffe:



#### WARNUNG

**Eine Betriebs- oder Wartungsanweisung, Verfahrensweise, Darstellung, Bedingung usw., die nicht strikt beachtet wird, kann zu Verletzungen oder zum Tode von Menschen führen.**



#### ACHTUNG

**Eine Betriebs- oder Wartungsanweisung, Verfahrensweise, Darstellung, Bedingung usw., die nicht strikt beachtet wird, kann zu Schäden am Gerät oder zu seiner Zerstörung führen.**

**Anmerkung:** Gilt für technische Forderungen, auf die der Betreiber ganz besonders achten muß.

**WARNUNG, ACHTUNG und ANMERKUNG** stehen immer dem Text voran, für den sie gelten.

## 2.1 Getriebe-Identifizierung

Das Typenschild ist auf dem Wendegetriebe angebracht.

Die Abb. 1 gibt das Beispiel eines Typenschildes an:

- A** Seriennummer des Getriebes.
  - B** Identnummer des Getriebes.
  - C** Übersetzungsverhältnis Gleichlauf
  - D** Übersetzungsverhältnis Gegenlauf.
  - E** Jedes Jahr wird ein progressives Schriftzeichen verwendet.
  - F** Typ des Getriebes.
- Bedeutung der Getriebezeichnung:
- G** Typ des Getriebes.
  - H** Größe
  - I** Ausführung

## 3.1 Beschreibung

Die Bootsswendegetriebe ZF M sind automatisch schaltbare Stirnradgetriebe.

Sie sind robust und zuverlässig. Trotzdem verlangen sie, daß der Einbau gemäß dieser Anleitung erfolgt und daß der Benutzer die Vorschriften für Bedienung und Wartung einhält.

Bei Nichtbeachtung besteht kein Garantieanspruch.

Service-Handbuch vom Hersteller zu beziehen.

Bild. 2:

- 1) Austausch
- 2) Ausgangsflansch
- 3) Kennzeichen
- 4) Betätigungshebel.
- 5) Fernbedienungsbügel.
- 6) Glocke.
- 7) Eingangswelle
- 8) Ölmesstab

## 4.1 Installation

Bei der Installation der ZF M Getriebe im Boot sollten folgende Dinge beachtet werden:

- Die Montage sollte nur von einem Spezialisten durchgeführt werden.
- **SCHRÄGLAGE:** (Bild. 3): Die Position des Getriebes darf im Bezug zur Eingangswelle bei Dauerbetrieb keinen Winkel über 20° (15° bei ZF MIV) einnehmen. Zulässige seitliche Schräglage nach Rückfrage beim Hersteller.

• **KUPPLUNGEN:** Motorseitig notwendig-torsionselastisch mit radialem Freigang (min. 0,5 mm). Propellerseitig empfehlenswert biegeelastisch.

• **MOTOR-GETRIEBE-VERBINDUNG** (Bild. 4):

- 1) Motorflansch
  - 2) Schwungrad
  - 3) Kupplung
  - 4) Getriebewelle
  - 5) Getriebeflansch
  - 6) Schwungradgehäuse
- Zulässiger Radial- und Planschlag  
X: K- 0,1 mm

• **GETRIEBE PROPELLERWELLEN-VERBINDUNG:** (Bild. 5 - 6):

• Wählen Sie einen passenden Wärmeaustauscher.

Detaillierte Angaben entnehmen Sie bitte dem Installationshandbuch.

**Ölsorte:** ATF (Automatic Transmission Fluid) siehe kapitel 10.1.

## 5.1 Bedienung

Bei allen HSW-Getrieben wird vor Auslieferung ein Prüflauf durchgeführt.

Das Getriebe sollte im Normalbetrieb nur bei Motor-Leerlaufdrehzahl geschaltet werden. In Notsituationen sind auch Schaltungen bei höheren Drehzahlen zulässig. Der korrekte Betrieb des hydraulischen Kreislaufs wird nur dann gewährleistet, wenn die hydraulische Flüssigkeit regelmäßig erneuert wird, so wie es der Wartungsplan vorsieht. (Siehe Kapitel 6.1). Sichtprüfungen auf undichte Stellen sollten von Zeit zu Zeit durchgeführt werden.



### WARNUNG

Arbeiten am Getriebe und Propeller dürfen nur durchgeführt werden, wenn Getriebe und Propeller stillstehen.



### ACHTUNG

Vor Inbetriebnahme des Getriebes muß Getriebeöl eingefüllt werden. Die Vorgehensweise, Öltyp, Füllmenge usw. finden Sie in Kapitel 6.1.4.



### ACHTUNG

Das Betreiben des Getriebes mit zu niedrigem Ölstand führt zu Getriebeschäden. Das Betreiben des Getriebes mit überhöhtem Ölstand kann Undichtigkeiten an den Dichtungen und der Entlüftungsöffnung verursachen und die Betriebstemperatur erheblich steigern. Wir empfehlen in jedem Fall die Verwendung eines Temperaturfühlers.

#### 5.1.1 BEDIENUNGSHINWEISE



### ACHTUNG

Vor Inbetriebnahme Ölstand überprüfen (siehe Kapitel 6.1.1).



### ACHTUNG

Das Getriebe sollte im Normalbetrieb nur bei Motor-Leerlaufdrehzahl geschaltet werden. Schalten bei höheren Drehzahlen kann zu Überbeanspruchung der Kupplung führen und sollte daher im Normalbetrieb vermieden werden.

**ANMERKUNG:** In Notsituationen kann das Getriebe bis zu einer hohen Motordrehzahl von Vor- auf Rücklauf geschaltet werden.

#### SCHALTPPOSITIONEN (Bild 7):

- A = Gegenlauf  
N = Leerlauf (neutral)  
B = Gleichlauf



### WARNUNG

Den Motor nur in Schaltposition «N» (Leerlauf) starten.

Die normale Betriebstemperatur des Getriebeöls muss zwischen 50°C (122°F) und 80°C (176°F) liegen. Nur kurzfristig darf die höchstzulässige Temperatur von 100°C (212°F) für das Öl ATF erreicht werden.



### ACHTUNG

Wenn die Öltemperatur zu hoch ist, Motor abstellen, den Getriebeöl-

stand kontrollieren und den Ölkühler auf richtigen Wasserdurchlauf überprüfen.

#### 5.1.2 SEGELN, SCHLEPP ODER VERANKERUNG

Wenn der Motor abgestellt ist und das Boot segelt, geschleppt wird oder am Anker liegt, kann der Propeller sich in der Strömung drehen.

Dies stellt keine Gefahr für das Getriebe dar. Bei einem Boot mit zwei Motoren kann der freilaufende Propeller des nicht benutzten Getriebes keinen Schaden verursachen. Wenn der Motor abgeschaltet ist, ist die Stellung des Schalthebels unwesentlich.



### ACHTUNG

Bei leerdrehender Propellerwelle muß die Schaltstellung «N» (Bild.7) sein. Zum Blockieren der Propellerwelle muß die der Fahrtrichtung entgegengesetzte Schaltstellung benützt werden, sonst entsteht Getriebeschaden.



### WARNUNG

Arbeiten Sie nicht am Getriebe, wenn das Boot abgeschleppt wird oder in einem Fluß ankert, da sich der Propeller drehen kann.



### WARNUNG

Arbeiten Sie nicht am Getriebe eines zwei Motorenbootes, bei dem ein Motor läuft, da sich der Propeller des abgeschalteten Getriebes drehen kann.



### WARNUNG

Wenn der Motor im Leerlauf läuft und die Propellerwelle aber nicht angetrieben werden soll (z.B. beim Aufladen der Batterie durch den Generator), muß der Schalthebel (Bild 7) in der neutralen Position (N) gehalten werden, da das Boot sich sonst bewegt.

Bei hydraulischen Schiffsgetriebe ist der Betrieb mit hohen Drehzahlen über einen längeren Zeitraum in der Neutralstellung nicht zulässig.

### 5.1.3 STEUERSYSTEM



#### ACHTUNG

Auf Leichtgängigkeit Gestänge/Seilzug ist zu achten.

#### SCHALTWEG:

Mod: ZF 5 M - 6 M - 10 M - 12 M - 15 M  
- 15 MA - 15 MIV - 25 M - 25 MA  
- 30 M.

Mindestschaltweg am Getriebeschalt-  
hebel (N-A=N-B) = 35 mm für äußeren  
und 30 mm für inneren Anlenkpunkt  
muß sicher erreicht werden.

#### Bild. 8:

- 1) Klemmschraube Anzugsmoment  
22 ± 1 Nm
- 2) Mindestschaltweg für Bowdenzug
- 3) Schaltdeckel **nicht** lösen
- 4) Ölablaßschraube  
Anzugsmoment: Ma = 22 Nm (16  
lb-ft).

#### SCHALTWEG:

Mod: ZF 4-1 M

Schaltweg (N-A=N-B) = 38,5 ± 1,5 mm  
für äußeren und 33,5 ± 1,5 mm für in-  
neren Anlenkpunkt muß sicher erreicht  
werden.

Wenn der Schalthebel durch die  
Drehung einen Winkel von 10°-12°  
erreicht, fängt er an, auch in die recht-  
winklige Richtung sich nach außen zu  
bewegen und er hält beim Endanschlag  
(Winkel von 40°).

#### Bild. 9:

- 1) Klemmschraube Anzugsmoment  
22 ± 1 Nm
- 2) Mutter nicht lösen
- 3) Schaltdeckel **nicht** lösen

**HEBELSTELLUNG** in Schaltstellung  
Null rechtwinklig zu Seilzug/Gestän-  
ge. Schalthebel mit Klemmschraube  
beliebig einstellbar. Abstand Schalt-  
hebel/Schaltdeckel mindestens 0,5  
mm. Lösen Schaltdeckel erfordert  
erneutes Einstellen (nur durch Fach-  
personal).

#### Bild. 10:

- 1) Ölmeßstab und Öleinfüllschraube  
SW 17

Anzugsmoment: Ma = 20 Nm (15  
lb-ft).

- 2) Schalthebelabstand min 0,5 mm

**KONTROLLEN:** Um den guten Betrieb  
zu gewährleisten, ist es erforderlich,  
die Hebelposition regelmäßig zu  
prüfen.

## 6.1 Wartung

### 6.1.1 ÖLSTAND ÜBERPRÜFEN



#### WARNUNG

**Wartungsarbeiten am Getriebe nur  
bei Motorstillstand durchführen.  
Tragen Sie immer Handschuhe,  
wenn an einem heißen Getriebe  
gearbeitet wird.**

#### BESCHREIBUNG ÖLMESSTAB (Abb. 11):

- 1) Gehäuseoberfläche.
- 2) Meßstab.
- 3) Ölspiegel.
- 4) ATF-Öl
- 5) Dichtungsscheibe.

Der Ölstand kann in kaltem oder hei-  
ßen Zustand überprüft werden.

**HINWEIS:** Bevor Sie das Wendege-  
triebe in Betrieb nehmen, immer den  
Ölstand prüfen. Dazu folgendermaßen  
vorgehen.

- Den Griff des Ölmeßstabes (Bild 11)  
entgegen dem Uhrzeigersinn drehen  
und aus dem Gehäuse ziehen.
- Das Öl am Ölmeßstab mit einem  
sauberen und staubfreien Lappen  
abwischen.
- Den Ölmeßstab in die Gehäuseboh-  
rung einstecken, nicht zuschrauben  
(3-4 Bild 11), wieder herausziehen  
und Ölstand ablesen. Die Ölmenge  
muß zwischen Min.- und Max.-Mar-  
kierung am Ölmeßstab sein.
- Den Ölmeßstab einführen und im  
Uhrzeigersinn festdrehen.



#### ACHTUNG

**Je nach Art und Anordnung von  
Kühler und Leitungen ergibt sich**

**nach dem Abstellen des Motors eine  
bestimmte Ölmenge, die bei länge-  
rer Stillstandszeit in das Getriebe  
zurückfließt.**

**Dabei entsteht im Getriebe ein Öl-  
stand, der über der Max.-Markierung  
stehen kann.**

**Das über der Max.-Markierung ste-  
hende Getriebeöl nicht absaugen.  
Die Arbeitsfolgen durchführen.**

- Den Motor starten und kurze Zeit  
mit Leerlaufdrehzahl laufen lassen,  
damit sich Kühler und Leitungen mit  
Getriebeöl füllen können.
- Motor abstellen und erneut den Öl-  
stand überprüfen. Falls notwendig,  
Öl nachfüllen.  
Der richtige Ölstand ist erreicht,  
wenn das Öl am Ölmeßstab (Bild  
11) zwischen der Min.- und Max.-  
Markierung sichtbar ist. Den Ölstand  
nach kurzer Anfahrzeit nochmals  
überprüfen.

### 6.1.2 ÖLWECHSEL



#### ACHTUNG

**Der erste Ölwechsel muß nach  
25 Betriebsstunden durchgeführt  
werden.**

**Alle weiteren Ölwechsel nach je-  
weils 300 Betriebsstunden oder im  
Abstand von einem Jahr.**



#### ACHTUNG

**Der verbrauchte Schmierstoff ist als  
Sonderabfall zu behandeln, der für  
die Umwelt schädlich ist: Er ist da-  
her aufgrund seiner differenzierten  
Struktur zu behandeln.**

### 6.1.3 GETRIEBEÖL ABSAUGEN

Den Stopfen (1 Abb. 12) entfernen und  
das Öl aus dem Stopfen im unteren Teil  
des Gehäuses ablaufen lassen.

### 6.1.4 GETRIEBEÖL EINFÜLLEN

Die Automatikbetriebe ATF mit Öl  
füllen und dabei die untenstehend  
angegebene Menge benutzen.

Die Menge hinzufügen, die man als erforderlich betrachtet, um den Wärmeaustauscher und die entsprechenden Anschlussleitungen zu füllen

- ZF 4-1 M: ..... 0,42 Liter
  - ZF 5 M: ..... 0,42 Liter
  - ZF 6 M: ..... 0,42 Liter
  - ZF 10 M: ..... 0,42 Liter
  - ZF 12 M: ..... 0,60 Liter
  - ZF 15 M: ..... 0,60 Liter
  - ZF 15 MA: ..... 0,56 Liter
  - ZF 15 MIV: ..... 1,00 Liter
  - ZF 25 M: ..... 0,75 Liter
  - ZF 25 MA: ..... 0,75 Liter
  - ZF 30 M: mind. 0,90 - max. 1,10 Liter
- Gilt für Neigungen der unteren Welle bis zu 20 Grad (15° für ZF MIV).

Ausschließlich Öl für Automatikgetriebe benutzen, so wie es in der «Liste der empfohlenen Ölsorten» auf Seite 82 steht.

**6.1.5 PROBELAUF**

- 1) Nach dem Ölwechsel ist ein Probelauf durchzuführen.
- 2) Den Schalthebel auf Neutral-Position (N) stellen. Den Motor starten und kurze Zeit in Leerlaufdrehzahl laufen lassen, damit sich Kühler und Leitungen mit Getriebeöl füllen können.
- 3) Motor abstellen und erneut den Ölstand überprüfen. Falls notwendig, Öl nachfüllen. Zuviel eingefülltes Öl ist abzusaugen.

Der richtige Ölstand ist erreicht, wenn das Öl am Ölmeßstab zwischen der Min.- und Max.-Markierung sichtbar ist. Den Ölstand nach kurzer Anfahrzeit nochmals überprüfen.

**6.1.6 LAGERUNG**

Wenn das Getriebe für längere Zeit gelagert wird, zum Beispiel in der Winterzeit, ist das Getriebe durch die Öffnung des Ölmeßstabes bis zum Rand mit dem vorgeschriebenen ATF-Getriebeöl zu füllen, um es vor Korrosion zu schützen.



**ACHTUNG**

**Bei Wiederinbetriebnahme ist ein Ölwechsel durchzuführen.**

**7.1 Fehlersuche**

Überprüfen Sie zuerst ob alle Vorschriften der Bedienungsanleitung beachtet wurden.

STÖRUNG	MÖGLICHE URSACHE	ABHILFE
<b>1. Hohe Öltemperatur</b>	<ul style="list-style-type: none"> <li>- Ölstand während des Betriebs zu hoch</li> <li>- Ölstand zu niedrig</li> <li>- Verstopfter Kühler oder Leitungen durchspülen kein Kühlwasser im Kühlersystem</li> </ul>	<ul style="list-style-type: none"> <li>- Öl absaugen bis zur Maximalanzeige des Ölmeßstabes</li> <li>- Öl nachfüllen</li> <li>- Kühler austauschen und für Wasserdurchlauf sorgen</li> <li>- Kühlersystem überprüfen und ggf. reparieren</li> </ul>
<b>2. Öl auf dem Getriebegehäuse</b>	<ul style="list-style-type: none"> <li>- Lose Schrauben</li> <li>- Lose Verschraubungen</li> <li>- Ölmeßstab sitzt nicht fest</li> <li>- Ölstand während des Betriebs zu hoch</li> </ul>	<ul style="list-style-type: none"> <li>- Festziehen gemäß Spezifikation</li> <li>- Festziehen, auswechseln</li> <li>- Bis zum Anschlag einschrauben, auswechseln</li> <li>- Öl absaugen bis zur Maximalanzeige des Ölmeßstabes</li> </ul>
<b>3. Schwergängige Schaltung</b>	<ul style="list-style-type: none"> <li>- Schalteinrichtung</li> <li>- Gestänge</li> </ul>	<ul style="list-style-type: none"> <li>- Servicewerkstatt konsultieren</li> <li>- Einstellen/justieren</li> </ul>
<b>4. Langsames Einrasten der Gänge</b>	<ul style="list-style-type: none"> <li>- Schalteinrichtung</li> <li>- Gestänge</li> </ul>	<ul style="list-style-type: none"> <li>- Servicewerkstatt konsultieren</li> <li>- Einstellen/justieren</li> </ul>
<b>5. Keine Bootsbewegung</b>	<ul style="list-style-type: none"> <li>- Schalteinrichtung</li> <li>- Gang nicht richtig geschaltet</li> <li>- Propeller verloren</li> <li>- Propeller gebrochen</li> <li>- Fehlfunktion des Getriebes</li> <li>- Fehlfunktion des Motors</li> </ul>	<ul style="list-style-type: none"> <li>- Servicewerkstatt konsultieren</li> <li>- Korrekt schalten</li> <li>- Neuen Propeller montieren</li> <li>- Servicewerkstatt konsultieren</li> <li>- Servicewerkstatt konsultieren</li> <li>- Sercicewerkstatt konsultieren</li> </ul>



## 8.1 Technische daten

### Technical Data for Pleasure Craft Duty

Based on engine power B to DIN 6270; shock factor

K = 1.25 to be applied, if engine has 1 cylinder / K = 1.20 for 2 cylinders / K = 1.15 for 3 cylinders

MODEL	RATIO		POWER / RPM		INPUT POWER CAPACITY						MAX RPM	WEIGHT		BELL HSGS. AND NOTES
	«A» Pos	«B»Pos	kW	hp	2800 rpm		3000 rpm		3600 rpm			kg	lb	
					kW	hp	kW	hp	kW	hp				
ZF 5 M	2.045	1.864	0.0066	0.0088	18	25	20	27	20	27	8.5	19	SAE 6, B/W Max input power 20 kW	
	2.722	2.150	0.0047	0.0063	13	18	14	19	17	23				5000

K = 1.25 to be applied, if engine has 1 cylinder / K = 1.20 for 2 cylinders / K = 1.15 for 3 cylinders

MODEL	RATIO		POWER / RPM		INPUT POWER CAPACITY						MAX RPM	WEIGHT		BELL HSGS. AND NOTES
	«A» Pos	«B»Pos	kW	hp	2800 rpm		3000 rpm		3600 rpm			kg	lb	
					kW	hp	kW	hp	kW	hp				
ZF 6 M	2.045	1.864	0.0066	0.0088	18	25	20	27	20	27	10.3	23	SAE 4, 5, 6, B/W Max input power 20 kW	
	2.722	2.150	0.0047	0.0063	13	18	14	19	17	23				5000

K = 1.25 to be applied, if engine has 1 cylinder / K = 1.20 for 2 cylinders / K = 1.15 for 3 cylinders

\*\* Max. 95 Nm (70 ft lb) admissible for main travelling direction with gear lever set to «B»

MODEL	RATIO		POWER / RPM		INPUT POWER CAPACITY						MAX RPM	WEIGHT		BELL HSGS. AND NOTES						
	«A» Pos	«B»Pos	kW	hp	2800 rpm		3000 rpm		3600 rpm			kg	lb							
					kW	hp	kW	hp	kW	hp										
ZF 10 M	1.482	1.864	0.0109	0.0146	30	41	33	44	38	51	10.3	23	SAE 4, 5, 6, B/W Max input power 38 kW. Ratio 1.482 «B» Pos. max torque 95 Nm. Ratio 1.792 «B» Pos. max torque 95 Nm.							
	1.792	1.864																		
	2.045	1.864												27	36	29	38	34	46	5000
	2.722	2.150												0.0095	0.0128	19	26	20	27	25

K = 1.25 to be applied, if engine has 1 cylinder / K = 1.20 for 2 cylinders / K = 1.15 for 3 cylinders

MODEL	RATIO		POWER / RPM		INPUT POWER CAPACITY						MAX RPM	WEIGHT		BELL HSGS. AND NOTES
	«A» Pos	«B»Pos	kW	hp	2800 rpm		3000 rpm		3600 rpm			kg	lb	
					kW	hp	kW	hp	kW	hp				
ZF 12 M	2.136	1.955	0.0131	0.0176	37	49	39	53	47	63	13	29	SAE 4, 5, 6, B/W, Yanmar JH Max input power 55 kW	
	2.632	1.955	0.0111	0.0149	31	42	33	45	40	54				5000

K = 1.25 to be applied, if engine has 1 cylinder / K = 1.20 for 2 cylinders / K = 1.15 for 3 cylinders

\*\* Max. 120 Nm (88.5 ft lb) admissible for main travelling direction with gear lever set to «B»

MODEL	RATIO		POWER / RPM		INPUT POWER CAPACITY						MAX RPM	WEIGHT		BELL HSGS. AND NOTES
	«A» Pos	«B»Pos	kW	hp	3000 rpm		3600 rpm		3800 rpm			kg	lb	
					kW	hp	kW	hp	kW	hp				
ZF 15 M	1.556	1.955	0.0152	0.0204	46	61	55	73	55	74	13	29	SAE 4, 5, 6, B/W, Yanmar JH Max input power 55 kW. Ratio 1.556 «B» Pos. max torque 120 Nm. Ratio 1.875 «B» Pos. max torque 120 Nm.	
	1.875	1.955												

«A» POS = continuous running position (normally AHEAD).

«B» POS = reverse position.

B/W = Borg Warner adaptor.

Note = For all «M» (Mechanical) transmissions reduce power capacity by the following shock factors: 1 cylinder engine ÷ 1.25, 2 cylinder engine ÷ 1.20, 3 cylinder engine ÷ 1.15.





## Betriebsanleitung ZF 4-1 M / ZF 30 M

**K = 1.25 to be applied, if engine has 1 cylinder / K = 1.20 for 2 cylinders / K = 1.15 for 3 cylinders**

\*\* Max. 120 Nm (88.5 ft lb) admissible for main travelling direction with gear lever set to «B»

MODEL	RATIO		POWER / RPM		INPUT POWER CAPACITY						MAX RPM	WEIGHT		BELL HSGS. AND NOTES
	«A» Pos	«B»Pos	kW	hp	kW	hp	kW	hp	kW	hp		kg	lb	
					3000 rpm	3600 rpm	3800 rpm							
ZF 15 MA 8 degrees	1.875	1.955	0.0152	0.0204	46	61	55	73	55	74	13.5	30	SAE 4, 5, 6, B/W, Yanmar JH Max input power 55 kW. <b>Ratio 1.875 «B» Pos. max torque 120 Nm. Ratio 2.136 «B» Pos. max torque 120 Nm.</b>	
	2.136	1.955	0.0131	0.0176	39	53	47	63	50	67				
	2.632	1.955	0.0111	0.0149	33	45	40	54	42	57				

**K = 1.25 to be applied, if engine has 1 cylinder / K = 1.20 for 2 cylinders / K = 1.15 for 3 cylinders**

\* Max. 120 Nm (88.5 ft lb) admissible for main travelling direction with gear lever set to «B».

\*\* Max 45 kW for main travelling direction with gear lever set to «B».

MODEL	RATIO		POWER / RPM		INPUT POWER CAPACITY						MAX RPM	WEIGHT		BELL HSGS. AND NOTES
	«A» Pos	«B»Pos	kW	hp	kW	hp	kW	hp	kW	hp		kg	lb	
					3000 rpm	3600 rpm	3800 rpm							
ZF 15 MIV 8 degrees	2.134	2.224	0.0152	0.0204	46	61	55	73	55	74	21	47	SAE 4, 5, B/W, Yanmar JH Max input power 55 kW. <b>Ratio 2.134 «B» Pos. max torque 120 Nm.</b>	
	2.718	2.224	0.0111	0.0149	33	45	40	54	42	57				
	2.995	2.224												

**K = 1.25 to be applied, if engine has 1 cylinder - K = 1.20 for 2 cylinders - K = 1.15 for 3 cylinders**

\*\* Max. 230 Nm (170 ft lb) admissible for main travelling direction with gear lever set to «B»

MODEL	RATIO		POWER / RPM		INPUT POWER CAPACITY						MAX RPM	WEIGHT		BELL HSGS. AND NOTES
	«A» Pos	«B»Pos	kW	hp	kW	hp	kW	hp	kW	hp		kg	lb	
					3000 rpm	3600 rpm	3800 rpm							
ZF 25 M	1.880	2.095	0.0262	0.0351	79	105	80	107	80	107	18.5	41	SAE 4, 5, B/W, Yanmar JH Max input power 80 kW. <b>Ratio 1.880 «B» Pos. max torque 230 Nm.</b>	
	2.273	2.095	0.0216	0.0289	65	87	78	104	80	107				
	2.737	2.722	0.0177	0.0237	53	71	64	85	67	90				

**K = 1.25 to be applied, if engine has 1 cylinder / K = 1.20 for 2 cylinders / K = 1.15 for 3 cylinders**

\*\* Max. 169 Nm (125 ft lb) admissible for main travelling direction with gear lever set to «B»

MODEL	RATIO		POWER / RPM		INPUT POWER CAPACITY						MAX RPM	WEIGHT		BELL HSGS. AND NOTES
	«A» Pos	«B»Pos	kW	hp	kW	hp	kW	hp	kW	hp		kg	lb	
					3000 rpm	3600 rpm	3800 rpm							
ZF 25 MA 8 degrees	2.227	2.737	0.0215	0.0288	64	86	77	104	80	107	21.1	47	SAE 4, 5, B/W, Yanmar JH Max input power 80 kW. <b>Ratio 2.227 «B» Pos. max torque 169 Nm.</b>	
	2.737	2.737	0.0177	0.0237	53	71	64	85	67	90				

**K = 1.25 to be applied, if engine has 1 cylinder / K = 1.20 for 2 cylinders / K = 1.15 for 3 cylinders**

\*\* Max. 185 Nm (137 ft lb) admissible for main travelling direction with gear lever set to «B»

MODEL	RATIO		POWER / RPM		INPUT POWER CAPACITY						MAX RPM	WEIGHT		BELL HSGS. AND NOTES
	«A» Pos	«B»Pos	kW	hp	kW	hp	kW	hp	kW	hp		kg	lb	
					3000 rpm	3600 rpm	3800 rpm							
ZF 30 M	2.148	2.636	0.0241	0.0323	72	97	87	116	92	123	23	51	4 & 5 Yanmar JH Max input power 95 kW. <b>Ratio 2.148 «B» Pos. max torque 185 Nm. Ratio 2.696 «B» Pos. max torque 185 Nm.</b>	
	2.696	2.636												

«A» POS = continuous running position (normally AHEAD).

«B» POS = reverse position.

B/W = Borg Warner adaptor.

Note = For all «M» (Mechanical) transmissions reduce power capacity by the following shock factors: 1 cylinder engine ÷ 1.25, 2 cylinder engine ÷ 1.20, 3 cylinder engine ÷ 1.15.

## 9.1 Garantie

### 9.1.1 GARANTIEBEDINGUNGEN

ZF Marine Arco S.p.A. gewährleistet das ZFM Schiffswendegetriebe als frei von Mängeln in Bezug auf Material und Verarbeitung bei normalem Gebrauch und Wartung, mit dem Vorbehalt, daß diese Gewährleistung ausschließlich gilt, wenn die Anlage einwandfrei eingebaut wurde und betrieben wird. Die Verpflichtung von ZF Marine Arco S.p.A. im Rahmen dieser Gewährleistung ist nach eigenem Ermessen auf den Austausch oder die Instandsetzung sämtlicher Teile beschränkt, die von ZF Marine Arco S.p.A. bei deren Untersuchung als mangelhaft festgestellt wurden, sofern das bzw. die Teile an den nächsten autorisierten Händler von ZF Marine Arco S.p.A., Fracht bezahlt, fristgerecht zurück-gegeben wurden:

Vierundzwanzig (24) Monate ab dem Auftragsdatum bzw. sechsunddreißig (36) Monate ab dem Inbetriebnahmedatum an den Motorenhersteller, was jeweils zuerst eintritt.

Die Verpflichtungen von ZF Marine Arco S.p.A. im Rahmen dieser Gewährleistung gelten mit dem Vorbehalt, daß der Händler bzw. Motorhersteller, der das Produkt erworben hat, die Gewährleistungsmaßnahmen erfüllt hat aufgeführt sind, der einen Bestandteil des Vertrages bildet.

Sämtlich Garantieansprüche sind den Händlern und Motorenherstellern vorzulegen, die das Getriebe verkauft haben. Diese Gewährleistung gilt nicht für diejenigen Teile, die ohne vorherige schriftliche Zustimmung eines autorisierten ZF Marine Arco S.p.A. Händlers instandgesetzt oder abgeändert wurden.

Diese Gewährleistung gilt nicht, wenn das Produkt oder eines seiner Bestandteile oder Bauteile Gegenstand eines Mißbrauchs, Fahrlässigkeit, Änderung oder Unfalls geworden ist bzw. nicht nach Maßgabe der gedruckten Anweisungen von ZF Marine Arco S.p.A. betrieben wurde bzw. unter Bedingungen betrieben wurde, die als erschwerender gelten oder in anderer Weise diejenigen überschreiten, die in den Spezifikationen für dieses Produkt festgelegt wurden bzw. unsachgemäß eingebaut oder wieder eingebaut oder unsachgemäß gewartet und betrieben wurden. Diese Gewährleistung tritt ausdrücklich an die Stelle sonstiger ausdrücklicher oder implizierter Gewährleistungen einschließlich derjenigen für marktgängige Qualität und Tauglichkeit für die Benutzung sowie aller sonstigen Verpflichtungen, u.a. einschließlich indirekter Folgeschäden. Und ZF Marine Arco S.p.A. übernimmt keine weitere Verpflichtung im Zusammenhang mit dem Verkauf des Getriebes, noch beauftragt ZF Marine Arco S.p.A. eine andere Person damit, eine solche Verpflichtung zu übernehmen. ZF Marine Arco S.p.A. ist unter keinen Umständen haftbar für irgendwelche Garantieverletzungen für einen Betrag, der über dem Einkaufspreis des Schiffswendegetriebes liegt.

### 9.1.2 VERANTWORTUNG FÜR DREHSCHWINGUNGEN UND DREHSCHWINGUNGSKUPPLUNGEN

Die Verantwortung für die Zusicherung einer Verträglichkeit von Drehschwingungen liegt beim Zusammensteller der Antriebsanlage.

ZF Marine Arco S.p.A. übernimmt keine Haftung für Getriebegeräusche,

die durch Schwingungen verursacht werden, oder für Schäden an dem Getriebe, der flexiblen Kupplung oder anderen Komponenten der Antriebsanlage, die durch solche Schwingungen verursacht werden. Für weitere Informationen und Unterstützung nehmen Sie bitte mit ZF Marine Arco S.p.A. Kontakt auf.

ZF Marine Arco S.p.A. empfiehlt für Einmotorenanlagen, wo der Ausfall der Antriebsleistung zu einem Verlust der Manövrierbarkeit führen kann, die Verwendung von Kupplungen mit einer Durchdrehsicherung. Es obliegt der Verantwortung des Käufers diese Option zu spezifizieren, die zusätzliche Kosten und eine eventuelle Zunahme der Einbaulänge zur Folge hat.

ZF Marine Arco S.p.A. übernimmt keine Haftung für Personenschäden, Todesfolgen oder für Sachschäden und Vermögensverlusten, die aus dem Versäumnis des Käufers resultieren eine Durchdrehsicherung zu spezifizieren. ZF wählt Drehschwingungskupplungen auf der Basis der Eingangsnennleistungen und der allgemein üblichen Motordrehzahlen aus. Fragen Sie bei ZF Marine Arco S.p.A. Einzelheiten bezüglich der Drehzahlbeschränkungen von standardmäßig angebotenen Drehschwingungskupplungen an, die kleiner als die Drehzahlbegrenzung der Getriebe sein können. Besondere Drehschwingungskupplungen können von Abnahmegesellschaften und für Iceclass-Abnahmen gefordert werden.

# FRANÇAIS

## Section

1.1	Introduction.....	26
2.1	Identification de l'inverseur.....	26
3.1	Description .....	26
4.1	Installation .....	26
5.1	Fonctionnement.....	27
6.1	Entretien.....	28
7.1	Recherche des pannes .....	29
8.1	Caractéristiques techniques.....	30
9.1	Garantie.....	32
10.1	Liste des huiles recommandées.....	82
11.1	Liste de distributeurs .....	83
12.1	Dessins d'installation.....	84
13.1	Warranty Card .....	95

## 1.1 Introduction

### 1.1.1 RESPONSABILITÉ DE L'UTILISATEUR

Il incombe à l'utilisateur de procéder aux contrôles de sécurité nécessaires pour s'assurer que toutes les conditions de lubrification, de refroidissement, d'entretien et autres soient respectées, afin de garantir une exploitation sans problème. Toutes les transmissions sont couvertes par une garantie. Par conséquent: Les instructions contenues dans le présent manuel doivent être strictement observées pour manipuler les transmissions.



#### ATTENTION

**Le fabricant ne saurait être tenu pour responsable des détériorations dues à une mauvaise installation, une manipulation incorrecte et un entretien insuffisant.**

**Le client doit s'assurer que des efforts excessifs tels que les vibrations causées par torsion et alignement défectueux soient évitées.**

**L'interaction entre le moteur, la ligne d'arbre et l'hélice peut conduire à des vibrations de torsion provoquant le martèlement des engrenages et risquant de détériorer le moteur et/ou la transmission. Le fournisseur ne saurait être tenu pour responsable des dites vibrations de torsion inhérentes à l'installation.**

Le présent manuel comprend entre autres les chapitres principaux suivants:

### 1.1.2 DESCRIPTION

Cette brève partie décrit des fonctions de l'exploitation et la conception des ZF M.

### 1.1.3 FONCTIONNEMENT

Cette partie décrit les procédures nécessaires au fonctionnement, de même que toutes les mesures de sécurité.

### 1.1.4 ENTRETIEN

Cette partie contient toutes les opérations d'entretien que l'utilisateur devra effectuer.

Les termes "droite, gauche, tribord, babord" utilisés dans le présent manuel se rapportent à la transmission installée dans le sens de déplacement vers l'avant.

Les informations importantes du point de vue technique et de la sécurité sont mises en relief comme suit:



#### DANGER

**Opération ou procédure de maintenance, pratique, condition, instruction etc., dont la non observation peut entraîner de graves blessures ou même des accidents mortels pour le personnel.**



#### ATTENTION

**Opération ou procédure de maintenance, pratique, condition, instruction etc., dont la non-observation peut détériorer ou détruire de l'équipement.**

**Remarque:** S'applique aux obligations techniques que l'utilisateur de l'équipement devra strictement respecter.

Les mots **DANGER**, **ATTENTION** et **REMARQUE** précèdent toujours le texte auxquels ils s'appliquent.

## 2.1 Identification de l'inverseur

La plaque signalétique est apposée sur l'inverseur. La Fig. 1 montre un exemple de plaque signalétique :

- A** Numéro de série de la transmission.
- B** Référence de la transmission.
- C** Rapport de transmission sens de

rotation de l'hélice identique au sens de rotation du moteur.

**D** Rapport de réduction sens de rotation de l'hélice inverse à celui du moteur.

**E** Chaque année nous utilisons une nouvelle lettre progressive.

**F** Type de transmission.

Signification des désignations de la transmission:

**G** Type de transmission.

**H** Taille de la transmission

**I** Version de la transmission

## 3.1 Description

Les inverseurs marins ZF M sont des transmissions à engrenages cylindriques, commandées par un mécanisme automatique.

Elle se distinguent par leur robustesse et leur grande fiabilité. Néanmoins, il est fortement recommandé de faire leur installation dans le respect absolu des directives figurant dans ce petit manuel et de suivre étroitement les consignes relatives à leur maniement et leur entretien. La non-observation de ces règles ou toute modification opérée sur l'inverseur entraînera la déchéance de la garantie du constructeur.

Sur demande, le constructeur vous fournira un manuel d'entretien.

Fig. 2:

- 1) Échangeur
- 2) Bride de sortie
- 3) Plaque signalétique d'identification
- 4) Levier de commande.
- 5) Support de la télécommande.
- 6) Cloche.
- 7) Arbre d'entrée
- 8) Jauge d'huile

## 4.1 Installation

Les points suivants doivent faire l'objet d'une attention particulière lors du montage des transmissions ZFM:

- Le montage doit être confié uniquement à un spécialiste.
- **INCLINAISON** (Fig. 3): La position de la transmission, par rapport à l'arbre d'entrée, ne doit pas dépasser d'un angle de 20° (15° pour ZF MIV), en service continu. Quant à l'inclinaison latérale admissible, prière de contacter le constructeur.
- **ACCOUPLLEMENTS:** Du côté moteur-obligatoire: accouplement élastique

à la torsion présentant un écart radial minimum de 0,5 mm; du côté hélice-recommandé: accouplement élastique à la flexion.

• **RACCORDEMENT MOTEUR-BOÎTE** (Fig. 4):

- 1) Flasque du moteur
- 2) Volant
- 3) Accouplement
- 4) Albero dell'invertitore
- 5) Flasque de la boîte
- 6) Boîtier du volant

Voilures admissible en directions radiale et axiale X: P- 0,1 mm

• **RACCORDEMENT BOÎTE-ARBRE D'HÉLICE** (Fig. 5 - 6):

• Choisir un refroidisseur adéquat.

Pour de plus amples informations, se reporter au Manuel d'Installation.

**Type d'huile:** ATF (Fluide de transmission automatique) voir chap. 10.1.

## 5.1 Fonctionnement

Toutes les transmissions ont fait l'objet d'essai avant l'expédition.

En utilisation normale, la transmission doit être enclenchée avec le moteur fonctionnant au ralenti.

En cas d'urgence, il est aussi possible d'inverser à des régimes élevés.

Vérifier visuellement les fuites d'huile de temps en temps.

Pour le bon fonctionnement du circuit hydraulique, il suffit de changer régulièrement le fluide hydraulique, conformément aux indications de l'entretien programmé. (Voir chapitre 6.1).

Vérifier visuellement les fuites d'huile de temps en temps.



### DANGER

**Le travail sur la transmission doit être pratiqué avec le moteur et la transmission à l'arrêt.**



### ATTENTION

**Avant la première mise en route, la transmission doit être remplie avec du fluide de transmission.**

**Pour la procédure de remplissage, type de fluide, quantité et niveau, se référer aux chapitres 6.1.4.**



### ATTENTION

**Utiliser la transmission avec un niveau d'huile insuffisant pourrait**

**endommager les engrenages. Un niveau d'huile excessif peut causer des fuites au niveau des bagues d'étanchéité et du reniflard, et augmenter considérablement la température en fonctionnement.**

### 5.1.1 PROCÉDURE D'EXPLOITATION



#### ATTENTION

**Vérifier le niveau d'huile avant d'utiliser la transmission (voir chapitre 6.1.1).**



#### ATTENTION

**En utilisation normale, il est préférable de manoeuvrer la transmission, le moteur étant au régime de ralenti. Manoeuvrer à des régimes moteur plus élevés peut entraîner une contrainte excessive sur les garnitures de friction, il convient donc de l'éviter en exploitation normale.**

**REMARQUE:** En cas d'urgence, il est possible de passer de marche avant en marche arrière, à un régime de vitesse élevé.

#### POSITIONS DU LEVIER (figure 7):

A = Rotation de l'hélice dans le sens opposé du moteur.

N = Position neutre (Point Mort).

B = Rotation de l'hélice dans le même sens que le moteur.



### DANGER

**Démarrer le moteur avec la transmission en position neutre.**

La température normale de service de l'huile de la transmission doit être comprise entre 50°C (122°F) et 80°C (176°F). Il est permis d'atteindre la température maximum admissible pour l'huile ATF de 100°C (212°F) que pour une brève période.



### ATTENTION

**Si la température du fluide est trop élevée, arrêter le moteur immédiatement, vérifier le niveau d'huile dans la transmission, et le débit d'eau dans le refroidisseur d'huile.**

**Ne pas démarrer le moteur avant d'avoir supprimé le défaut.**

### 5.1.2 NAVIGATION A VOILE, REMORQUE OU MOUILLAGE

Quand le moteur est arrêté, le bateau navigue à la voile, aussi bien remorqué que mouillé, l'hélice pouvant tourner par effet du courant.

Ceci ne présente aucun danger pour la transmission.

Dans un bateau à deux moteurs, l'hélice de la transmission non-utilisée peut tourner à vide librement.

Quand le moteur ne fonctionne pas, la position du levier de commande n'a aucune importance.



### ATTENTION

**Avec l'arbre d'hélice en marche à vide, le levier de commande doit être dans la position «N» (Fig.7).**

**Utilisez la position de commande contraire à la direction de course pour bloquer l'arbre de l'hélice, pour éviter un endommagement de la transmission.**



### DANGER

**Ne pas travailler sur une transmission pendant que le bateau est remorqué, ou ancré dans une rivière car l'hélice peut tourner.**



### DANGER

**Ne pas travailler sur une transmission dans un bateau à deux moteurs, lorsque l'un des deux fonctionne. L'arbre d'hélice de la transmission inopérante peut tourner.**



### DANGER

**Quand le moteur tourne à vide, tandis que l'arbre d'hélice est arrêté (par exemple quand les batteries se chargent avec l'alternateur), le levier de commande (figure 7) doit être en position neutre (N), pour que le bateau ne se déplace pas.**

**Éviter de faire tourner le moteur à haut régime longtemps en ayant le bloc hydraulique en position neutre.**



### 5.1.3 SYSTÈME DE COMMANDE



#### ATTENTION

La course utile du levier doit s'obtenir sans difficulté.

#### COURSE UTILE:

Mod: **ZF 5 M - 6 M - 10 M - 12 M - 15 M - 15 MA - 15 MIV - 25 M - 25 MA - 30 M.**

La course utile minimale (N-A=N-B) du levier de commande, soit 35 mm pour le point de raccordement extérieur, soit 30 mm pour le point de raccordement intérieur.

#### Fig. 8:

- 1) Vis de serrage moment de serrage  $22 \pm 1$  Nm
- 2) Course utile minima pour tirant à câble
- 3) **Ne pas démonter** le couvercle de commande
- 4) Bouchon de vidange d'huile  
Couple de serrage: Ma = 22 Nm (16 lb-ft).

#### COURSE UTILE:

Mod: **ZF 4-1 M**

La course utile(N-A=N-B) du levier de commande, soit  $38,5 \pm 1,5$  mm pour le point de raccordement extérieur, soit 33,5 mm pour le point de raccordement intérieur.

En partant de la position neutre, quand la levier du command pass par la position de  $10^\circ$ - $12^\circ$  elle commence a se déplacer vers l'extérieur in direction perpendiculaire, pour s'arrêter au but de la course ( $40^\circ$  angle).

#### Fig. 9:

- 1) Vis de serrage moment de serrage  $22 \pm 1$  Nm
- 2) Ne pas devisser l'écrou
- 3) **Ne pas démonter** le couvercle de commande

#### ORIENTATION DU LEVIER DE COMMANDE.

En position neutre, le levier doit être perpendiculaire aux tringles ou au câble. La facilité de mouvement du levier peut être réglée à volonté, à l'aide d'une vis de serrage. Respecter une distance minimale de 0,5 mm entre le levier et le couvercle de commande.

Après démontage et remontage de ce couvercle, faire procéder à un nouveau réglage (à effectuer par des spécialistes seulement).

#### Fig. 10:

- 1) Jauge et bouchon de remplissage d'huile (17 mm)  
Couple de serrage: Ma = 20 Nm (15 lb-ft).
- 2) Ecartement du lever 0,5 mm au minimum

**CONTRÔLES :** Afin de garantir le bon fonctionnement, il est nécessaire de contrôler régulièrement la position du levier.

## 6.1 Entretien

### 6.1.1 CONTRÔLE DU NIVEAU D'HUILE



#### DANGER

**Ne pas travailler sur une transmission en remorque ou au mouillage dans une rivière, car l'arbre d'hélice peut tourner.**

#### DESCRIPTION DE LA JAUGE D'HUILE (Fig. 11):

- 1) Face supérieure du boîtier
- 2) Jauge niveau d'huile
- 3) Niveau d'huile
- 4) Huile ATF
- 5) Rondelle d'étanchéité

Le niveau d'huile peut être contrôlé à chaud ou à froid.

**REMARQUE:** Contrôler toujours le niveau de l'huile avant la mise en service de l'inverseur en intervenant de la manière suivante :

- Desserrer la jauge (fig. 11) en tournant la poignée dans le sens inverse des aiguilles d'une montre.
- Essuyer la jauge avec un chiffon propre et sans poussière.
- Enfoncer la jauge sans visser, la retirer et contrôler le niveau d'huile. La niveau d'huile doit être entre le minimum et le maximum (3-4 fig. 11).
- Enfoncer la jauge et la verrouiller en tournant la poignée dans le sens des aiguilles d'une montre.



#### ATTENTION

Selon le type et la disposition du refroidisseur et des canalisations, une certaine quantité d'huile s'accumulera puis s'écoulera dans la transmission après un temps de repos. Ceci peut être la raison d'un niveau d'huile dans la transmission supérieur à la marque du maximum.

**Ne pas retirer l'excédent d'huile mais procéder comme l'indiquent les paragraphes.**

- Faire tourner le moteur au ralenti avec le levier de commande en position neutre afin que le refroidisseur et les canalisations soient remplis de fluide.
- Arrêter le moteur et vérifier à nouveau le niveau d'huile. Si nécessaire, compléter le niveau d'huile jusqu'à la marque sur la jauge. Le niveau d'huile sur la jauge (fig. 11) devra se situer entre les marques mini et maxi. Le niveau d'huile devra être vérifié à nouveau après une courte période de fonctionnement.

### 6.1.2 VIDANGE



#### ATTENTION

**La première vidange de l'huile s'effectuent après 25 heures de fonctionnement. Le suivant vidange s'effectuent toutes les 300 heures ou, au minimum, une fois par an.**



#### ATTENZIONE

**Le lubrifiant épuisé doit être traité comme un déchet spécial qui pollue l'environnement en donc éliminé en tenant compte de la structure différenciée.**

### 6.1.3 VIDANGE DE L'HUILE

Enlever le bouchon (1 Fig. 12) et laisser couler l'huile par l'orifice qui se trouve dans la partie basse de la boîte.

### 6.1.4 REMPLISSAGE D'HUILE

Remplir avec de l'huile pour boîte de vitesses automatiques ATF, en respectant les quantités indiquées.





Ajouter la quantité retenue nécessaire pour le remplissage de l'échangeur de chaleur et des tubes de raccord correspondants.

ZF 4-1 M: .....	0,42 litres
ZF 5 M: .....	0,42 litres
ZF 6 M: .....	0,42 litres
ZF 10 M: .....	0,42 litres
ZF 12 M: .....	0,60 litres
ZF 15 M: .....	0,60 litres
ZF 15 MA: .....	0,56 litres
ZF 15 MIV: .....	1,00 litres
ZF 25 M: .....	0,75 litres
ZF 25 MA: .....	0,75 litres
ZF 30 M: .min. 0,90 - max. 1,10 litres	

• Valable pour une inclinaison de l'arbre de moins de 20 degrés (15° pour ZF MIV).

Utiliser uniquement de l'huile pour boîte de vitesses automatiques sui-

vant les spécifications indiquées dans la «Liste des huiles recommandée» page 82.

### 6.1.5 ESSAI

- 1) Effectuer un essai après le changement d'huile.
- 2) Vérifier que le levier de commande est en position neutre (N). Démarrer le moteur et le laisser tourner au ralenti peu de temps afin que le refroidisseur et les canalisations soient remplis d'huile.
- 3) Arrêter le moteur et vérifier à nouveau le niveau d'huile. Si nécessaire, compléter le niveau avec de l'huile, l'huile excessive devra être aspirée. Le niveau d'huile sur la jauge devra être entre les marques mini et maxi.

Le niveau d'huile devra être contrôlé à nouveau après une courte période de fonctionnement.

### 6.1.6 STOCKAGE

Si la transmission reste longtemps sans fonctionner, par exemple pour hivernage, il convient de la remplir complètement par l'orifice de jauge avec de l'huile ATF pour la protéger contre la corrosion. Il est recommandé de vider l'eau du circuit de refroidissement.



#### ATTENTION

**Changer l'huile lors de la nouvelle mise en fonction de la transmission.**

## 7.1 Recherche des pannes

Commencer par vérifier que tous les points des présentes instructions d'exploitation ont été observés.

SYMPTOME	CAUSE POSSIBLE	REMÈDE
<b>1. Température d'huile élevée</b>	<ul style="list-style-type: none"> <li>- Niveau d'huile élevé durant le fonctionnement</li> <li>- Niveau d'huile bas</li> <li>- Refroidisseur encrassé</li> <li>- Pas d'eau dans le circuit de refroidissement</li> </ul>	<ul style="list-style-type: none"> <li>- Pomper l'huile pour redescendre au repère max. de la jauge</li> <li>- Ajouter de l'huile</li> <li>- Remplacer le refroidisseur et rincer les canalisations</li> <li>- Vérifier le circuit de refroidissement</li> </ul>
<b>2. Fuite d'huile</b>	<ul style="list-style-type: none"> <li>- Boulons desserrés</li> <li>- Raccords desserrés</li> <li>- Jauge desserrée</li> <li>- Niveau d'huile trop élevé</li> </ul>	<ul style="list-style-type: none"> <li>- Serrer selon les caractéristiques</li> <li>- Serrer, remplacer</li> <li>- Serrer, (remplacer)</li> <li>- Pomper l'huile pour abaisser le niveau au repère max. de la jauge</li> </ul>
<b>3. Enclenchements difficiles</b>	<ul style="list-style-type: none"> <li>- Commande du sélecteur</li> <li>- Liaison câble de commande</li> </ul>	<ul style="list-style-type: none"> <li>- Service d'entretien</li> <li>- Ajuster</li> </ul>
<b>4. Enclenchement trop lent</b>	<ul style="list-style-type: none"> <li>- Commande du sélecteur</li> <li>- Liaison câble de commande</li> </ul>	<ul style="list-style-type: none"> <li>- Service d'entretien</li> <li>- Ajuster</li> </ul>
<b>5. Le bateau ne démarre pas</b>	<ul style="list-style-type: none"> <li>- Hélice manquante</li> <li>- Arbre d'hélice cassé</li> <li>- Mauvais fonctionnement de la transmission</li> <li>- Mauvais fonctionnement du moteur</li> <li>- Liaison câble de commande</li> </ul>	<ul style="list-style-type: none"> <li>- Remplacer</li> <li>- Service d'entretien</li> <li>- Service d'entretien</li> <li>- Service d'entretien</li> <li>- Ajuster</li> </ul>



## 8.1 Caractéristiques techniques

### Technical Data for Pleasure Craft Duty

Based on engine power B to DIN 6270; shock factor

**K = 1.25 to be applied, if engine has 1 cylinder / K = 1.20 for 2 cylinders / K = 1.15 for 3 cylinders**

MODEL	RATIO		POWER / RPM		INPUT POWER CAPACITY						MAX RPM	WEIGHT		BELL HSGS. AND NOTES
	«A» Pos	«B»Pos	kW	hp	2800 rpm		3000 rpm		3600 rpm			kg	lb	
					kW	hp	kW	hp	kW	hp				
ZF 5 M	2.045	1.864	0.0066	0.0088	18	25	20	27	20	27	5000	8.5	19	SAE 6, B/W Max input power 20 kW
	2.722	2.150	0.0047	0.0063	13	18	14	19	17	23				

**K = 1.25 to be applied, if engine has 1 cylinder / K = 1.20 for 2 cylinders / K = 1.15 for 3 cylinders**

MODEL	RATIO		POWER / RPM		INPUT POWER CAPACITY						MAX RPM	WEIGHT		BELL HSGS. AND NOTES
	«A» Pos	«B»Pos	kW	hp	2800 rpm		3000 rpm		3600 rpm			kg	lb	
					kW	hp	kW	hp	kW	hp				
ZF 6 M	2.045	1.864	0.0066	0.0088	18	25	20	27	20	27	5000	10.3	23	SAE 4, 5, 6, B/W Max input power 20 kW
	2.722	2.150	0.0047	0.0063	13	18	14	19	17	23				

**K = 1.25 to be applied, if engine has 1 cylinder / K = 1.20 for 2 cylinders / K = 1.15 for 3 cylinders**

\*\* Max. 95 Nm (70 ft lb) admissible for main travelling direction with gear lever set to «B»

MODEL	RATIO		POWER / RPM		INPUT POWER CAPACITY						MAX RPM	WEIGHT		BELL HSGS. AND NOTES
	«A» Pos	«B»Pos	kW	hp	2800 rpm		3000 rpm		3600 rpm			kg	lb	
					kW	hp	kW	hp	kW	hp				
ZF 10 M	1.482	1.864	0.0109	0.0146	30	41	33	44	38	51	5000	10.3	23	SAE 4, 5, 6, B/W Max input power 38 kW. <b>Ratio 1.482 «B» Pos. max torque 95 Nm. Ratio 1.792 «B» Pos. max torque 95 Nm.</b>
	1.792	1.864												
	2.045	1.864	0.0095	0.0128	27	36	29	38	34	46				
	2.722	2.150	0.0068	0.0091	19	26	20	27	25	33				

**K = 1.25 to be applied, if engine has 1 cylinder / K = 1.20 for 2 cylinders / K = 1.15 for 3 cylinders**

MODEL	RATIO		POWER / RPM		INPUT POWER CAPACITY						MAX RPM	WEIGHT		BELL HSGS. AND NOTES
	«A» Pos	«B»Pos	kW	hp	2800 rpm		3000 rpm		3600 rpm			kg	lb	
					kW	hp	kW	hp	kW	hp				
ZF 12 M	2.136	1.955	0.0131	0.0176	37	49	39	53	47	63	5000	13	29	SAE 4, 5, 6, B/W, Yanmar JH Max input power 55 kW
	2.632	1.955	0.0111	0.0149	31	42	33	45	40	54				

**K = 1.25 to be applied, if engine has 1 cylinder / K = 1.20 for 2 cylinders / K = 1.15 for 3 cylinders**

\*\* Max. 120 Nm (88.5 ft lb) admissible for main travelling direction with gear lever set to «B»

MODEL	RATIO		POWER / RPM		INPUT POWER CAPACITY						MAX RPM	WEIGHT		BELL HSGS. AND NOTES
	«A» Pos	«B»Pos	kW	hp	3000 rpm		3600 rpm		3800 rpm			kg	lb	
					kW	hp	kW	hp	kW	hp				
ZF 15 M	1.556	1.955	0.0152	0.0204	46	61	55	73	55	74	5000	13	29	SAE 4, 5, 6, B/W, Yanmar JH Max input power 55 kW. <b>Ratio 1.556 «B» Pos. max torque 120 Nm. Ratio 1.875 «B» Pos. max torque 120 Nm.</b>
	1.875	1.955												

«A» POS = continuous running position (normally AHEAD).

«B» POS = reverse position.

B/W = Borg Warner adaptor.

Note = For all «M» (Mechanical) transmissions reduce power capacity by the following shock factors: 1 cylinder engine ÷ 1.25, 2 cylinder engine ÷ 1.20, 3 cylinder engine ÷ 1.15.



**K = 1.25 to be applied, if engine has 1 cylinder / K = 1.20 for 2 cylinders / K = 1.15 for 3 cylinders**

\*\* Max. 120 Nm (88.5 ft lb) admissible for main travelling direction with gear lever set to «B»

MODEL	RATIO		POWER / RPM		INPUT POWER CAPACITY						MAX RPM	WEIGHT		BELL HSGS. AND NOTES
	«A» Pos	«B»Pos	kW	hp	3000 rpm		3600 rpm		3800 rpm			kg	lb	
					kW	hp	kW	hp	kW	hp				
ZF 15 MA 8 degrees	1.875	1.955	0.0152	0.0204	46	61	55	73	55	74	5000	13.5	30	SAE 4, 5, 6, B/W, Yanmar JH Max input power 55 kW. <b>Ratio 1.875 «B» Pos. max torque 120 Nm. Ratio 2.136 «B» Pos. max torque 120 Nm.</b>
	2.136	1.955	0.0131	0.0176	39	53	47	63	50	67				
	2.632	1.955	0.0111	0.0149	33	45	40	54	42	57				

**K = 1.25 to be applied, if engine has 1 cylinder / K = 1.20 for 2 cylinders / K = 1.15 for 3 cylinders**

\* Max. 120 Nm (88.5 ft lb) admissible for main travelling direction with gear lever set to «B».

\*\* Max 45 kW for main travelling direction with gear lever set to «B».

MODEL	RATIO		POWER / RPM		INPUT POWER CAPACITY						MAX RPM	WEIGHT		BELL HSGS. AND NOTES
	«A» Pos	«B»Pos	kW	hp	3000 rpm		3600 rpm		3800 rpm			kg	lb	
					kW	hp	kW	hp	kW	hp				
ZF 15 MIV 8 degrees	2.134	2.224	0.0152	0.0204	46	61	55	73	55	74	5000	21	47	SAE 4, 5, B/W, Yanmar JH Max input power 55 kW. <b>Ratio 2.134 «B» Pos. max torque 120 Nm.</b>
	2.718	2.224	0.0111	0.0149	33	45	40	54	42	57				
	2.995	2.224												

**K = 1.25 to be applied, if engine has 1 cylinder - K = 1.20 for 2 cylinders - K = 1.15 for 3 cylinders**

\*\* Max. 230 Nm (170 ft lb) admissible for main travelling direction with gear lever set to «B»

MODEL	RATIO		POWER / RPM		INPUT POWER CAPACITY						MAX RPM	WEIGHT		BELL HSGS. AND NOTES
	«A» Pos	«B»Pos	kW	hp	3000 rpm		3600 rpm		3800 rpm			kg	lb	
					kW	hp	kW	hp	kW	hp				
ZF 25 M	1.880	2.095	0.0262	0.0351	79	105	80	107	80	107	5000	18.5	41	SAE 4, 5, B/W, Yanmar JH Max input power 80 kW. <b>Ratio 1.880 «B» Pos. max torque 230 Nm.</b>
	2.273	2.095	0.0216	0.0289	65	87	78	104	80	107				
	2.737	2.722	0.0177	0.0237	53	71	64	85	67	90				

**K = 1.25 to be applied, if engine has 1 cylinder / K = 1.20 for 2 cylinders / K = 1.15 for 3 cylinders**

\*\* Max. 169 Nm (125 ft lb) admissible for main travelling direction with gear lever set to «B»

MODEL	RATIO		POWER / RPM		INPUT POWER CAPACITY						MAX RPM	WEIGHT		BELL HSGS. AND NOTES
	«A» Pos	«B»Pos	kW	hp	3000 rpm		3600 rpm		3800 rpm			kg	lb	
					kW	hp	kW	hp	kW	hp				
ZF 25 MA 8 degrees	2.227	2.737	0.0215	0.0288	64	86	77	104	80	107	5000	21.1	47	SAE 4, 5, B/W, Yanmar JH Max input power 80 kW. <b>Ratio 2.227 «B» Pos. max torque 169 Nm.</b>
	2.737	2.737	0.0177	0.0237	53	71	64	85	67	90				

**K = 1.25 to be applied, if engine has 1 cylinder / K = 1.20 for 2 cylinders / K = 1.15 for 3 cylinders**

\*\* Max. 185 Nm (137 ft lb) admissible for main travelling direction with gear lever set to «B»

MODEL	RATIO		POWER / RPM		INPUT POWER CAPACITY						MAX RPM	WEIGHT		BELL HSGS. AND NOTES
	«A» Pos	«B»Pos	kW	hp	3000 rpm		3600 rpm		3800 rpm			kg	lb	
					kW	hp	kW	hp	kW	hp				
ZF 30 M	2.148	2.636	0.0241	0.0323	72	97	87	116	92	123	5000	23	51	4 & 5 Yanmar JH Max input power 95 kW. <b>Ratio 2.148 «B» Pos. max torque 185 Nm. Ratio 2.696 «B» Pos. max torque 185 Nm.</b>
	2.696	2.636												

«A» POS = continuous running position (normally AHEAD).

«B» POS = reverse position.

B/W = Borg Warner adaptor.

Note = For all «M» (Mechanical) transmissions reduce power capacity by the following shock factors: 1 cylinder engine ÷ 1.25, 2 cylinder engine ÷ 1.20, 3 cylinder engine ÷ 1.15.

## 9.1 Garantie

### 9.1.1 GARANTI LIMITÉE

ZF Marine Arco S.p.A. garantit les inverseurs marins de type ZFM afin d'éliminer les défauts du matériel et de main d'oeuvre; ceci dans des conditions d'utilisation et d'entretien normales. Cette garantie ne sera appliquée que si, et seulement si, le matériel a été installé et entretenu correctement.

L'engagement que prend ZF Marine Arco S.p.A. dans le cadre de cette garantie se limite au remplacement ou à la réparation, au choix, du/des éléments reconnus défectueux par ZF Marine Arco S.p.A.

Ces éléments doivent être renvoyés au distributeur officiel ZF Marine Arco S.p.A. plus proche, en port payé, dans un délai limité à:

Vingt-quatre (24) mois à partir de mise en service ou trente-six (36) mois à partir de la date de livraison chez le fabricant de moteurs, que ce soit l'une ou l'autre des actions qui se passe en premier.

Les engagements de ZF Marine Arco S.p.A. dans le cadre de la garantie présentée ci-dessus doivent être comparés aux Procédures de Garantie qui fait entièrement partie de cette garantie - comparaison qui doit être effectuée par le distributeur ou le fabricant de moteurs ayant acheté le produit.

Toutes les pièces en garantie doivent revenir aux distributeurs et aux constructeurs de moteurs qui ont acheté l'inverseur ZF.

Cette garantie ne s'appliquera pas aux pièces réparées ou abimées qui

n'auraient pas obtenu préalablement l'accord écrit d'un distributeur officiel de ZF Marine Arco S.p.A..

Cette garantie ne s'appliquera pas si le produit ou l'un de ces composants a fait l'objet d'une mauvaise utilisation, d'une négligence, d'une modification ou d'un accident. Elle ne s'appliquera pas non plus si le produit n'a pas été utilisé conformément aux instructions imprimées par ZF Marine Arco S.p.A. ou dans des conditions plus sévères dépassant celles mentionnées. Elle ne s'appliquera pas non plus si le produit a été mal installé, réinstallé, mal entretenu ou encore mal utilisé. Cette garantie remplace expressément toutes les autres garanties énoncées ou implicites y compris les garanties commerciales, les garanties d'utilisation appropriées et toute autre garantie sans dégât consécutif. ZF Marine Arco S.p.A. n'autorisera aucune autre personne à assumer, à sa place, une quelconque responsabilité en relation avec la vente d'inverseurs ZFM.

ZF Marine Arco S.p.A. ne pourra en aucun cas être tenu responsable de violation de contrat si le montant de la réparation dépasse le prix d'achat de l'inverseur réducteur marin ZFM.

### 9.1.2 RESPONSABILITÉ TORSIONNELLE ET ACCOUPLEMENTS TORSIONNELLE

Celui qui est chargé de l'assemblage du système de propulsion et de la partie entraînée porte la responsabilité de la compatibilité torsionnelle.

ZF Marine Arco S.p.A. se dégage de toute responsabilité en cas de bruit

de l'inverseur/réducteur causé par des vibrations ou en cas de dommage causé à l'inverseur/réducteur, à l'accouplement élastique ou à d'autres composants du système de propulsion en raison de ce type de vibration.

Veillez contacter ZF Marine Arco S.p.A. pour toutes informations et assistance complémentaires.

ZF Marine Arco S.p.A. recommande l'utilisation d'une sécurité positive sur accouplement élastique pour les bateaux équipés d'un seul moteur, d'où perte de puissance de propulsion pouvant entraîner perte de contrôle. Il est de la responsabilité de l'acheteur de spécifier cette option qui peut engendrer surcoût et augmentation possible de la longueur d'installation. La responsabilité de ZF Marine Arco S.p.A. ne peut être engagée en cas de blessure, décès, dommage ou perte de propriété dus au fait que l'acheteur n'a pas demandé de sécurité positive sur l'accouplement élastique situé entre moteur et inverseur-réducteur.

ZF Marine Arco S.p.A. sélectionne les accouplements sur la base des valeurs de définition du couple d'entraînement nominal et du régime nominal du moteur communément accepté. Veillez contacter ZF Marine Arco S.p.A. pour toutes informations concernant les limites de vitesse des accouplements torsionnels de la gamme standard qui peuvent être inférieurs à la limite de transmission. Des accouplements spéciaux peuvent être demandés par les Sociétés de Classification.

# ESPAÑOL

## Contenido

1.1	Introducción.....	33
2.1	Identificación del inversor.....	33
3.1	Descripción.....	33
4.1	Instalación.....	33
5.1	Funcionamiento.....	34
6.1	Mantenimiento.....	35
7.1	Búsqueda fallos.....	36
8.1	Datos técnicos.....	37
9.1	Garantía.....	39
10.1	Lista de aceites recomendados.....	82
11.1	Lista puntos de asistencia.....	83
12.1	Planos de instalación.....	84
13.1	Warranty Card.....	95

## 1.1 Introducción

### 1.1.1 RESPONSABILIDAD DEL CLIENTE

El cliente/usuario es responsable de efectuar los controles para asegurar que la lubricación, la refrigeración, el mantenimiento y todo lo recomendado en el presente manual se cumplan estrictamente a fin de lograr que el inversor funcione de manera correcta y con total seguridad. Cada inversor está cubierto por una garantía, por lo tanto, para que ésta sea válida, es necesario seguir estrictamente las instrucciones presentes en este manual.



#### ATENCIÓN

**El fabricante no se hace responsable de los daños o las pérdidas derivadas de una mala instalación, empleo incorrecto del equipo e insuficiente mantenimiento del mismo. El Cliente debe verificar que no haya ningún tipo de fuerza externa ni vibraciones torsionales, causadas por torsión o flexión.**

**La interacción entre motor, eje de cola y hélice puede ocasionar vibraciones torsionales produciendo un ruido constante de los engranajes que puede dañar el motor y/o el inversor.**

**El Fabricante no se hace responsable de dichas vibraciones torsionales inherentes a la instalación.**

Este manual se compone de tres capítulos principales:

### 1.1.2 DESCRIPCIÓN

Esta parte describe brevemente la función, la utilización y las partes del inversor ZF M.

### 1.1.3 UTILIZACIÓN

En esta parte se describen todas las instrucciones de uso y todas las medidas de seguridad necesarias.

### 1.1.4 MANTENIMIENTO

Esta parte contiene todas las tareas de mantenimiento y de servicio que debe efectuar el usuario.

Los términos «izquierdo, derecho, babor y estribor» utilizados en este manual, se refieren siempre a inversores instalados con dirección de marcha avante.

La información importante concerniente la fiabilidad técnica y la seguridad de empleo está evidenciada de la siguiente manera:



#### PELIGRO

**Todos los procedimientos, usos, condiciones y recomendaciones, etc., que no se respeten escrupulosamente, pueden causar daño o la muerte del usuario.**



#### ATENCIÓN

**Todos los procedimientos, usos, condiciones y recomendaciones, etc., que no se respeten escrupulosamente, pueden dañar o destruir el equipo.**

**NOTA:** Están referidas a aspectos técnicos a los cuales el usuario del equipo debe prestar particular atención.

**PELIGRO, ATENCIÓN y NOTA** preceden siempre el texto al que se refieren.

## 2.1 Identificación del inversor

La placa de identificación está aplicada sobre el inversor.

La Fig. 1 expone un ejemplo de placa de identificación.

**A** Número de serie del inversor.

**B** Referencia de la transmisión

**C** Relación de transmisión de hélice que gira en la misma dirección del motor.

**D** Relación de transmisión de hélice que gira en dirección opuesta a la del motor.

**E** Cada año se asigna una letra diferente y progresiva.

**F** Tipo de inversor.

Significado de la denominación de los inversores:

**G** Tipo de inversor.

**H** Dimensión del inversor

**I** Versión del inversor

## 3.1 Descripción

Los inversores marinos ZF M son transmisiones de engranajes helicoidales comandadas por un mecanismo automático.

Estos se distinguen por su robustez y fiabilidad. Aún así aconsejamos que se observen escrupulosamente las siguientes instrucciones para la instalación, el uso y el mantenimiento.

El incumplimiento de las instrucciones contenidas en este manual o toda modificación al inversor no autorizada, quita toda validez a la garantía.

Bajo pedido el fabricante puede suministrar el manual de reparación.

Fig. 2:

- 1) Intercambiador
- 2) Brida de salida
- 3) Placa de identificación
- 4) Palanca de accionamiento.
- 5) Soporte telemando.
- 6) Campana
- 7) Árbol de entrada
- 8) Varilla nivel aceite

## 4.1 Instalación

Cuando se instala un inversor ZF M se deben seguir escrupulosamente las siguientes indicaciones:

- La instalación la debe efectuar solamente el personal especializado.
- **POSICIÓN INCLINADA** (Fig. 3): La posición de la transmisión, respecto al árbol de entrada, no debe exceder de un ángulo de 20° (15° para ZF MIV), en servicio continuo. Para lo que se refiere a la inclinación lateral permitida contactar al fabricante.
- **JUNTA ELÁSTICA:** Entre motor e inversor es necesario montar una junta de unión elástica con juego radial mínimo (0.5 mm); entre inversor y eje hélice, aconsejamos una unión con junta flexible.



• **ACOPLAMIENTO MOTOR-TRANSMISIÓN:** (Fig. 4):

- 1) Brida motor
- 2) Volante
- 3) Junta elástica
- 4) Árbol del inversor
- 5) Brida inversor
- 6) Brida volante

Valores máximos admisibles radiales y axiales X: K- 0,1 mm

• **ACOPLAMIENTO TRANSMISIÓN - EJE DE HÉLICE:** (Fig. 5 - 6):

- Instalar un enfriador de aceite adecuado.

Para más información, consultar el manual de instalación.

**Tipo de aceite:** ATF (Fluido Automático para Transmisión) ver Cáp. 10.1.

## 5.1 Funcionamiento

Todas las transmisiones pasan una prueba final de funcionamiento antes del envío.

En condiciones normales de funcionamiento está permitida la inversión de marcha sólo cuando el motor se encuentra al ralentí. De todas formas, en caso de emergencia está permitida la inversión también a revoluciones más altas.

La correcta funcionalidad del circuito hidráulico está garantizada sólo si se cambia regularmente el fluido hidráulico, como está previsto en el mantenimiento programado (véase capítulo 6.1).

Controlar visualmente, de vez en cuando, la presencia de eventuales pérdidas de aceite.



### PELIGRO

Intervenir en el inversor solamente cuando el motor y la hélice se encuentran parados.



### ATENCIÓN

En el momento de la puesta en marcha la transmisión se debe llenar con el aceite hidráulico indicado. Para el procedimiento de llenado, tipo de fluido, cantidad y nivel, ver los capítulos 6.1.4.



### ATENCIÓN

El uso del inversor con una cantidad insuficiente de aceite dañará los engranajes. Una cantidad excesiva

de aceite puede causar pérdidas por los retenes de los ejes y el respiradero y puede hacer aumentar considerablemente la temperatura de funcionamiento.

### 5.1.1 PUESTA EN MARCHA



### ATENCIÓN

Antes de poner en funcionamiento el inversor controlar el nivel del aceite (ver capítulo 6.1.1)



### ATENCIÓN

En condiciones normales, la palanca de inversión se debe accionar con el motor al ralentí. Las inversiones efectuadas a un número de revoluciones más elevado pueden provocar una sobrecarga de los discos del embrague y esto se debe evitar durante el funcionamiento normal.

**NOTA:** En caso de emergencia se puede efectuar la inversión, de marcha adelante a marcha atrás con el motor a gran velocidad.

### POSICIONES DE FUNCIONAMIENTO (figura 7):

A = Dirección de rotación de la hélice opuesta a la del motor.

N = Posición neutral

B = Dirección de rotación de la hélice igual a la del motor.



### PELIGRO

Arrancar el motor solamente cuando la palanca de accionamiento se encuentra en posición neutral.

La temperatura normal de trabajo del aceite de la transmisión debe estar comprendida entre los 50°C (122°F) y 80°C (176°F). Es posible alcanzar sólo durante un breve periodo de tiempo la máxima temperatura de 100°C (212°F) admitida para el aceite ATF.



### ATENCIÓN

Si la temperatura es demasiado elevada, detenga inmediatamente el motor, controle el nivel del fluido en el inversor y asegúrese de que el enfriador de aceite trabaja correctamente.

No arranque de nuevo el motor haber que se haya eliminado la causa del mal funcionamiento.

### 5.1.2 NAVEGACIÓN A VELA REMOLQUE O ANCLAJE

Cuando el motor está apagado y la embarcación navega a vela, ya sea que se la remolca o bien que esté anclada, la hélice puede girar por efecto de la corriente. Esto no daña la transmisión.

En una embarcación con dos motores, cuando sólo funciona uno, la hélice del motor que está apagado puede girar libremente.

Cuando el motor está apagado la posición de la palanca de mando es irrelevante.



### ATENCIÓN

Con el eje de la hélice en posición libre la posición de la palanca de mando debe estar en «N» (Fig. 7). Utilizar la posición de mando contraria a la de avance si se quiere bloquear el eje de la hélice, de lo contrario se provocan daños a la transmisión.



### PELIGRO

No efectuar ninguna intervención en la transmisión durante el remolque o cuando la embarcación esté anclada en un río ya que la hélice puede girar.



### PELIGRO

No efectuar ninguna intervención en la transmisión de una instalación doble cuando uno de los dos motores esté encendido. La hélice del que está parado puede girar.



### PELIGRO

Cuando el motor gira al ralentí y se desea que la hélice no gire (por ejemplo, al cargar la batería con la embarcación parada), la palanca de accionamiento debe encontrarse en posición neutral N (Fig. 7). Prohibido utilizar los reductores hidráulicos en neutro a altas revoluciones durante tiempos prolongados.

### 5.1.3 SISTEMA DE MANDO



#### ATENCIÓN

Controlar que el cable de mando se mueva libremente.

#### CARRERA ÚTIL:

Mod: ZF 5 M - 6 M - 10 M - 12 M - 15 M - 15 MA - 15 MIV - 25 M - 25 MA - 30 M.

El trayecto útil mínimo (N-A=N-B) de la palanca de mando, medida en el orificio de anclaje externo, debe ser al menos de 35 mm; y medida en el orificio interno de al menos 30 mm.

#### Fig. 8:

- 1) Tornillos de ajuste palanca  
Par de apriete  $22 \pm 1$  Nm
- 2) Carrera mínima para el cable de mando
- 3) **No** desmontar la tapa de mando
- 4) Tapón descarga aceite  
Par de apriete:  $M_a = 22$  Nm (16 lb-ft).

#### CARRERA ÚTIL:

Mod: ZF 4-1 M

La carrera útil (N-A=N-B) de la palanca de mando, medida en el orificio de anclaje externo, debe ser de  $38,5 \pm 1,5$  mm, si se mide en el orificio interno de 33,5 mm. Cuando, de la posición neutra, la palanca girando efectúa un ángulo de  $10^\circ$ - $12^\circ$ , la misma comienza a moverse también en dirección perpendicular hacia el externo y se para al final de carrera (ángulo de  $40^\circ$ ).

#### Fig. 9:

- 1) Tornillos de ajuste palanca  
Par de apriete  $22 \pm 1$  Nm
- 2) No aflojar la tuerca
- 3) **No** desmontar la tapa de mando

**POSICIÓN DE LA PALANCA:** En posición neutra se debe encontrar en posición perpendicular al cable de mando. La palanca se puede girar y fijar después en cualquier posición mediante el tornillo de ajuste.

La palanca se debe encontrar a la distancia mínima de la tapa de 0,5 mm. El desmontaje, o aún solo el aflojamiento de los tornillos de la tapa, requieren un nuevo ajuste de los mismos (que debe efectuar sólo el personal autorizado).

#### Fig. 10:

- 1) Varilla de aceite y tapón de llenado del aceite (17 mm)  
Par de apriete:  $M_a = 20$  Nm (15 lb-ft).

- 2) Distancia palanca mando de la tapa mín 0,5 mm

**CONTROLES:** Para garantizar el buen funcionamiento es necesario controlar con regularidad la posición de la palanca.

## 6.1 Mantenimiento

### 6.1.1 CONTROL DEL NIVEL DE ACEITE



#### PELIGRO

No efectuar ninguna intervención en la transmisión durante el remolque o cuando la embarcación esté anclada en un río ya que la hélice puede girar.

#### DESCRIPCIÓN VARILLA ACEITE (Fig. 11):

- 1) Superficie caja
- 2) Varilla nivel aceite
- 3) Nivel aceite
- 4) Aceite ATF
- 5) Arandela estanca

El nivel de aceite se puede controlar en frío o en caliente.

**NOTA:** Controlar siempre el nivel del aceite antes de la puesta en función del inversor operando del siguiente modo:

- Aflojar la varilla del aceite (Fig. 11) girándola manualmente en sentido antihorario y extraerla.
- Limpiar la varilla con un trapo limpio y sin polvo.
- Meter la varilla sin ajustarla; sacarla y controlar que el nivel del aceite se encuentre entre las marcas de mínimo y de máximo (3-4 Fig. 11).
- Volver a introducir la varilla y bloquearla girando en sentido horario.



#### ATENCIÓN

**Al apagar el motor, el aceite presente en el circuito hidráulico comenzará a fluir a la transmisión; dicha cantidad depende del tipo de enfriador y del circuito hidráulico usados para la refrigeración.**

**Después de cierto tiempo el aceite se habrá recogido en el inversor y esto alzará el nivel. No retirar el exceso de aceite, sino proceder de acuerdo.**

- Dejar girar el motor al ralentí con el inversor en posición neutral hasta que el enfriador de aceite y los tubos del circuito hidráulico se hayan llenado de aceite.

- Apagar el motor y enseguida controlar el nivel del aceite; si es necesario restablecer el nivel. El nivel del fluido debe estar comprendido entre las marcas de máximo y mínimo presentes en la varilla (Fig. 11). Repetir la operación después de un breve periodo de funcionamiento.

### 6.1.2 CAMBIO DEL ACEITE



#### ATENCIÓN

El primer cambio de aceite se debe efectuar después de 25 horas de funcionamiento. Los sucesivos cambios de aceite se deben efectuar al menos cada 300 horas de funcionamiento y de todas maneras no debe pasar más de un año entre un cambio y otro.



#### ATENCIÓN

El lubricante usado se deberá tratar como desecho especial que contamina el ambiente: se deberá por lo tanto eliminar en función de su estructura diferenciada.

### 6.1.3 VACIADO DEL ACEITE

Quitar el tapón (1 Fig. 12) y hacer salir el aceite por el respectivo orificio situado en la parte inferior de la caja.

### 6.1.4 LLENADO CON ACEITE ATF

Llenar con aceite para cambios automáticos ATF respetando las cantidades indicadas a continuación. Agregar la cantidad que se considere necesaria par el llenado del cambiador de calor y de los respectivos tubos de unión.

ZF 4-1 M: .....	0,42 litros
ZF 5 M: .....	0,42 litros
ZF 6 M: .....	0,42 litros
ZF 10 M: .....	0,42 litros
ZF 12 M: .....	0,60 litros
ZF 15 M: .....	0,60 litros
ZF 15 MA: .....	0,56 litros
ZF 15 MIV: .....	1,00 litros
ZF 25 M: .....	0,75 litros
ZF 25 MA: .....	0,75 litros
ZF 30 M: .min. 0,90 - max. 1,10 litros	

• Válido para inclinación del árbol inferior a 20 grados ( $15^\circ$  para ZF MIV).

Usar únicamente aceite para cambios automáticos como se especifica en la “Lista de los aceites aconsejados” en la pág.82.

### 6.1.5 PRUEBA DE FUNCIONAMIENTO

- 1) Efectuar una prueba de funcionamiento después del cambio de aceite.
- 2) Posicionar la palanca de mando en posición neutral (N).  
Arrancar el motor y dejarlo girar al

ralentí durante un breve periodo hasta que el enfriador de aceite y también el circuito hidráulico se llenen de aceite de la transmisión.

- 3) Parar el motor y controlar de nuevo el nivel de aceite. Si es necesario, restablecer el nivel. El aceite en exceso se debe eliminar.  
El nivel en la varilla de aceite debe encontrarse entre las marcas Mín y Máx. Es necesario volver a controlar el nivel de aceite después de un breve periodo de funcionamiento.

### 6.1.6 ALMACENAMIENTO

Si la transmisión se almacena durante un largo periodo, por ejemplo, durante el invierno, se debe llenar completamente de aceite ATF por el orificio de la varilla de nivel, de este modo se protege el grupo de la corrosión.



#### ATENCIÓN

**Cambiar el aceite cuando la transmisión se vuelva a poner en funcionamiento.**

## 7.1 Búsqueda fallos

Antes que nada controlar si se han llevado a cabo las instrucciones indicadas en los puntos precedentes.

ANOMALÍA	POSIBLE CAUSA	SOLUCIÓN
1. Alta temperatura del aceite	<ul style="list-style-type: none"> <li>- Nivel de aceite demasiado alto.</li> <li>- Nivel de aceite bajo</li> <li>- Enfriador de aceite obstruido</li> <li>- Falta de agua en el circuito.</li> </ul>	<ul style="list-style-type: none"> <li>- Quitar el exceso de aceite hasta alcanzar la marca max. en la varilla de nivel.</li> <li>- Restablecer el nivel</li> <li>- Sustituir el enfriador y controlar el circuito del agua.</li> <li>- Controlar el circuito y reparar la pérdida.</li> </ul>
2. Presencia de aceite en la carcasa	<ul style="list-style-type: none"> <li>- Tornillos flojos</li> <li>- Uniones flojas</li> <li>- Varilla del aceite floja</li> <li>- Nivel de aceite demasiado alto durante el funcionamiento</li> </ul>	<ul style="list-style-type: none"> <li>- Apretar al par recomendado.</li> <li>- Apretar o sustituir.</li> <li>- Apretar o sustituir.</li> <li>- Aspirar hasta la marca máx.</li> </ul>
3. Embragada dura	<ul style="list-style-type: none"> <li>- Bloqueo distribuidor</li> <li>- Telemando</li> </ul>	<ul style="list-style-type: none"> <li>- Consultar un centro de asistencia</li> <li>- Regulación</li> </ul>
4. Embragada lenta	<ul style="list-style-type: none"> <li>- Bloqueo distribuidor</li> <li>- Telemando</li> </ul>	<ul style="list-style-type: none"> <li>- Consultar un centro de asistencia</li> <li>- Regulación</li> </ul>
5. La embarcación no se mueve	<ul style="list-style-type: none"> <li>- Bloqueo distribuidor</li> <li>- Posición errónea de palanca</li> <li>- Pérdida de la hélice</li> <li>- Rotura del eje hélice</li> <li>- La transmisión no funciona bien</li> <li>- El motor funciona mal</li> </ul>	<ul style="list-style-type: none"> <li>- Consultar un centro de asistencia</li> <li>- Regulación de la palanca de mando</li> <li>- Volver a instalar</li> <li>- Consultar un centro de asistencia</li> <li>- Consultar un centro de asistencia</li> <li>- Consultar un centro de asistencia</li> </ul>

## 8.1 Datos técnicos

### Technical Data for Pleasure Craft Duty

Based on engine power B to DIN 6270; shock factor

K = 1.25 to be applied, if engine has 1 cylinder / K = 1.20 for 2 cylinders / K = 1.15 for 3 cylinders

MODEL	RATIO		POWER / RPM		INPUT POWER CAPACITY						MAX RPM	WEIGHT		BELL HSGS. AND NOTES
	«A» Pos	«B»Pos	kW	hp	2800 rpm		3000 rpm		3600 rpm			kg	lb	
					kW	hp	kW	hp	kW	hp				
ZF 5 M	2.045	1.864	0.0066	0.0088	18	25	20	27	20	27	8.5	19	SAE 6, B/W Max input power 20 kW	
	2.722	2.150	0.0047	0.0063	13	18	14	19	17	23				5000

K = 1.25 to be applied, if engine has 1 cylinder / K = 1.20 for 2 cylinders / K = 1.15 for 3 cylinders

MODEL	RATIO		POWER / RPM		INPUT POWER CAPACITY						MAX RPM	WEIGHT		BELL HSGS. AND NOTES
	«A» Pos	«B»Pos	kW	hp	2800 rpm		3000 rpm		3600 rpm			kg	lb	
					kW	hp	kW	hp	kW	hp				
ZF 6 M	2.045	1.864	0.0066	0.0088	18	25	20	27	20	27	10.3	23	SAE 4, 5, 6, B/W Max input power 20 kW	
	2.722	2.150	0.0047	0.0063	13	18	14	19	17	23				5000

K = 1.25 to be applied, if engine has 1 cylinder / K = 1.20 for 2 cylinders / K = 1.15 for 3 cylinders

\*\* Max. 95 Nm (70 ft lb) admissible for main travelling direction with gear lever set to «B»

MODEL	RATIO		POWER / RPM		INPUT POWER CAPACITY						MAX RPM	WEIGHT		BELL HSGS. AND NOTES
	«A» Pos	«B»Pos	kW	hp	2800 rpm		3000 rpm		3600 rpm			kg	lb	
					kW	hp	kW	hp	kW	hp				
ZF 10 M	1.482	1.864	0.0109	0.0146	30	41	33	44	38	51	10.3	23	SAE 4, 5, 6, B/W Max input power 38 kW. <b>Ratio 1.482 «B» Pos.</b> <b>max torque 95 Nm. Ratio</b> <b>1.792 «B» Pos. max</b> <b>torque 95 Nm.</b>	
	1.792	1.864												
	2.045	1.864	0.0095	0.0128	27	36	29	38	34	46				5000
	2.722	2.150	0.0068	0.0091	19	26	20	27	25	33				5000

K = 1.25 to be applied, if engine has 1 cylinder / K = 1.20 for 2 cylinders / K = 1.15 for 3 cylinders

MODEL	RATIO		POWER / RPM		INPUT POWER CAPACITY						MAX RPM	WEIGHT		BELL HSGS. AND NOTES
	«A» Pos	«B»Pos	kW	hp	2800 rpm		3000 rpm		3600 rpm			kg	lb	
					kW	hp	kW	hp	kW	hp				
ZF 12 M	2.136	1.955	0.0131	0.0176	37	49	39	53	47	63	13	29	SAE 4, 5, 6, B/W, Yanmar JH Max input power 55 kW	
	2.632	1.955	0.0111	0.0149	31	42	33	45	40	54				5000

K = 1.25 to be applied, if engine has 1 cylinder / K = 1.20 for 2 cylinders / K = 1.15 for 3 cylinders

\*\* Max. 120 Nm (88.5 ft lb) admissible for main travelling direction with gear lever set to «B»

MODEL	RATIO		POWER / RPM		INPUT POWER CAPACITY						MAX RPM	WEIGHT		BELL HSGS. AND NOTES
	«A» Pos	«B»Pos	kW	hp	3000 rpm		3600 rpm		3800 rpm			kg	lb	
					kW	hp	kW	hp	kW	hp				
ZF 15 M	1.556	1.955	0.0152	0.0204	46	61	55	73	55	74	13	29	SAE 4, 5, 6, B/W, Yanmar JH Max input power 55 kW. <b>Ratio 1.556 «B» Pos.</b> <b>max torque 120 Nm.</b> <b>Ratio 1.875 «B» Pos.</b> <b>max torque 120 Nm.</b>	
	1.875	1.955												

«A» POS = continuous running position (normally AHEAD).

«B» POS = reverse position.

B/W = Borg Warner adaptor.

Note = For all «M» (Mechanical) transmissions reduce power capacity by the following shock factors: 1 cylinder engine ÷ 1.25, 2 cylinder engine ÷ 1.20, 3 cylinder engine ÷ 1.15.



**K = 1.25 to be applied, if engine has 1 cylinder / K = 1.20 for 2 cylinders / K = 1.15 for 3 cylinders**

\*\* Max. 120 Nm (88.5 ft lb) admissible for main travelling direction with gear lever set to «B»

MODEL	RATIO		POWER / RPM		INPUT POWER CAPACITY						MAX RPM	WEIGHT		BELL HSGS. AND NOTES
	«A» Pos	«B»Pos	kW	hp	kW	hp	kW	hp	kW	hp		kg	lb	
					3000 rpm	3600 rpm	3800 rpm							
ZF 15 MA 8 degrees	1.875	1.955	0.0152	0.0204	46	61	55	73	55	74	13.5	30	SAE 4, 5, 6, B/W, Yanmar JH Max input power 55 kW. <b>Ratio 1.875 «B» Pos. max torque 120 Nm. Ratio 2.136 «B» Pos. max torque 120 Nm.</b>	
	2.136	1.955	0.0131	0.0176	39	53	47	63	50	67				
	2.632	1.955	0.0111	0.0149	33	45	40	54	42	57				

**K = 1.25 to be applied, if engine has 1 cylinder / K = 1.20 for 2 cylinders / K = 1.15 for 3 cylinders**

\* Max. 120 Nm (88.5 ft lb) admissible for main travelling direction with gear lever set to «B».

\*\* Max 45 kW for main travelling direction with gear lever set to «B».

MODEL	RATIO		POWER / RPM		INPUT POWER CAPACITY						MAX RPM	WEIGHT		BELL HSGS. AND NOTES
	«A» Pos	«B»Pos	kW	hp	kW	hp	kW	hp	kW	hp		kg	lb	
					3000 rpm	3600 rpm	3800 rpm							
ZF 15 MIV 8 degrees	2.134	2.224	0.0152	0.0204	46	61	55	73	55	74	21	47	SAE 4, 5, B/W, Yanmar JH Max input power 55 kW. <b>Ratio 2.134 «B» Pos. max torque 120 Nm.</b>	
	2.718	2.224	0.0111	0.0149	33	45	40	54	42	57				
	2.995	2.224												

**K = 1.25 to be applied, if engine has 1 cylinder - K = 1.20 for 2 cylinders - K = 1.15 for 3 cylinders**

\*\* Max. 230 Nm (170 ft lb) admissible for main travelling direction with gear lever set to «B»

MODEL	RATIO		POWER / RPM		INPUT POWER CAPACITY						MAX RPM	WEIGHT		BELL HSGS. AND NOTES
	«A» Pos	«B»Pos	kW	hp	kW	hp	kW	hp	kW	hp		kg	lb	
					3000 rpm	3600 rpm	3800 rpm							
ZF 25 M	1.880	2.095	0.0262	0.0351	79	105	80	107	80	107	18.5	41	SAE 4, 5, B/W, Yanmar JH Max input power 80 kW. <b>Ratio 1.880 «B» Pos. max torque 230 Nm.</b>	
	2.273	2.095	0.0216	0.0289	65	87	78	104	80	107				
	2.737	2.722	0.0177	0.0237	53	71	64	85	67	90				

**K = 1.25 to be applied, if engine has 1 cylinder / K = 1.20 for 2 cylinders / K = 1.15 for 3 cylinders**

\*\* Max. 169 Nm (125 ft lb) admissible for main travelling direction with gear lever set to «B»

MODEL	RATIO		POWER / RPM		INPUT POWER CAPACITY						MAX RPM	WEIGHT		BELL HSGS. AND NOTES
	«A» Pos	«B»Pos	kW	hp	kW	hp	kW	hp	kW	hp		kg	lb	
					3000 rpm	3600 rpm	3800 rpm							
ZF 25 MA 8 degrees	2.227	2.737	0.0215	0.0288	64	86	77	104	80	107	21.1	47	SAE 4, 5, B/W, Yanmar JH Max input power 80 kW. <b>Ratio 2.227 «B» Pos. max torque 169 Nm.</b>	
	2.737	2.737	0.0177	0.0237	53	71	64	85	67	90				

**K = 1.25 to be applied, if engine has 1 cylinder / K = 1.20 for 2 cylinders / K = 1.15 for 3 cylinders**

\*\* Max. 185 Nm (137 ft lb) admissible for main travelling direction with gear lever set to «B»

MODEL	RATIO		POWER / RPM		INPUT POWER CAPACITY						MAX RPM	WEIGHT		BELL HSGS. AND NOTES
	«A» Pos	«B»Pos	kW	hp	kW	hp	kW	hp	kW	hp		kg	lb	
					3000 rpm	3600 rpm	3800 rpm							
ZF 30 M	2.148	2.636	0.0241	0.0323	72	97	87	116	92	123	23	51	4 & 5 Yanmar JH Max input power 95 kW. <b>Ratio 2.148 «B» Pos. max torque 185 Nm. Ratio 2.696 «B» Pos. max torque 185 Nm.</b>	
	2.696	2.636												

«A» POS = continuous running position (normally AHEAD).

«B» POS = reverse position.

B/W = Borg Warner adaptor.

Note = For all «M» (Mechanical) transmissions reduce power capacity by the following shock factors: 1 cylinder engine ÷ 1.25, 2 cylinder engine ÷ 1.20, 3 cylinder engine ÷ 1.15.



## 9.1 Garantía

### 9.1.1 CONDICIONES DE LA GARANTÍA

ZF Marine Arco S.p.A. garantiza sus inversores serie ZFM ante cualquier defecto del material y/o de mano de obra siempre que se hayan utilizado en condiciones normales y se haya efectuado un mantenimiento correcto. Esta garantía es válida sólo si la instalación se ha realizado correctamente y la transmisión se ha utilizado de manera correcta.

ZF Marine Arco S.p.A. se obliga con esta garantía a la sustitución o a la reparación, a su elección, de la parte o de las partes reconocidas como defectuosas por ZF Marine Arco S.p.A., después de haberlas examinado, a condición de que la parte o las partes se entreguen al distribuidor oficial ZF Marine Arco S.p.A. más cercano, con los gastos de transporte pre-pagados, dentro de: Veinticuatro (24) meses a partir de la fecha instalación o treinta y seis (36) meses desde la fecha de expedición al fabricante de motores, lo que antes suceda primero.

Las obligaciones de ZF Marine Arco S.p.A. bajo la presente garantía, tal y como está expresado, están además condicionadas al respeto escrupuloso de los Procedimientos de Garantía por parte del distribuidor o fabricante de motores que ha comercializado el producto.

Todas las solicitudes de garantía se deberán presentar al distribuidor o fabricante de motores que ha comercializado la transmisión ZF.

Esta garantía no es válida en el caso de que una o más partes hayan sido reparadas o modificadas sin el consentimiento escrito de un vendedor oficial ZF Marine Arco S.p.A.

Asimismo, la garantía no es válida si el producto o alguno de sus componentes o partes no se han usado correctamente, ante negligencia, modificaciones o accidentes y si no se han seguido las instrucciones escritas de ZF Marine Arco S.p.A. o han funcionado en condiciones más difíciles o no especificadas para el mencionado producto, o han sido instalados y utilizados de manera incorrecta o han tenido un mantenimiento deficiente.

Esta garantía sustituye cualquier otra garantía explícita o implícita incluyendo la garantía de comercialización y de buen uso y otras eventuales obligaciones que comprendan daños indirectos derivados de la utilización del producto. ZF Marine Arco S.p.A. no se responsabiliza ni autoriza a otras personas a asumir en su nombre responsabilidades relacionadas con la venta del inversor ZFM. ZF Marine Arco S.p.A. en ningún caso es responsable de daños que superen el precio de compra del inversor ZFM.

### 9.1.2 RESPONSABILIDAD POR TORSIONALES Y ACOPLAMIENTOS ELÁSTICOS

La responsabilidad de asegurar la compatibilidad torsional recae sobre el montador del conjunto motor.

ZF Marine Arco S.p.A. no acepta ninguna responsabilidad por el ruido de

la transmisión causado por las vibraciones o el daño a la transmisión, el acoplamiento elástico o cualquier otra parte del conjunto motor causada por este tipo de vibración.

Contacte con ZF Marine Arco S.p.A. para una mayor información o asistencia.

ZF Marine Arco S.p.A. recomienda la aplicación de un límite torsional para embarcaciones con un solo motor, en donde la pérdida de potencia puede dar lugar a la pérdida de control.

Es responsabilidad del comprador especificar esta aplicación que puede resultar en costes adicionales y en incrementos de la instalación.

ZF Marine Arco S.p.A. no acepta ninguna responsabilidad por daños personales, pérdida de vidas o daños en la propiedad debido a un fallo del comprador al especificar el límite torsional.

ZF Marine Arco S.p.A. selecciona los acoplamientos elásticos basándose en el par de entrada nominal y son comúnmente aceptados para los diferentes regímenes de velocidad de los motores.

Consulte a ZF Marine Arco S.p.A. para los detalles relativos a los límites de velocidad para los acoplamientos standard, que pueden ser menos que los límites de la transmisión.

Las Sociedades de Clasificación para la clase hielo pueden exigir acoplamientos especiales.

## NORSK

### Kapittel

1.1	Eiers ansvar .....	40
2.1	Identifisering av giret .....	40
3.1	Beskrivelse .....	40
4.1	Installasjon .....	40
5.1	Betjening .....	41
6.1	Vedlikehold .....	42
7.1	Feilsøking .....	42
8.1	Tekniske data .....	44
9.1	Garanti .....	46
10.1	Liste over anbefalt smøreolje ...	82
11.1	Forhandlerliste .....	83
12.1	Installasjons tegning .....	84
13.1	Warranty Card .....	95

## 1.1 Eiers ansvar

### 1.1.1 KUNDENS ANSVAR

Eieren og brukeren har ansvar for å foreta nødvendige sikkerhetskontroller, påse at det er tilstrekkelig smøre- og kjølemedler, samt å overholde foreskrevne vedlikeholdsforskrifter. Alle girenheter er dekket av en garanti. Derfor: Når det gjelder håndteringen av girenhetene, må instruksjonene i håndboken følges nøye.



**VIKTIG**

**Produsenten er hverken ansvarlig for feil installering, feil behandling av utstyret eller utilstrekkelig vedlikehold.**

**Eieren må sikre at ytre krefter ikke virker på utstyret gjennom torsjon eller bøyning, da det skaper vibrasjon.**

**Vekselvirkningen mellom motor, aksel og propell kan medføre torsjonsvridning, som forårsaker hammerlignende støy og, under visse omstendigheter, fører til skader på giret og motoren.**

**ZF Marine Arco S.p.A. er ikke ansvarlig for torsjonsvridninger som skyldes installeringen.**

Brukermanualen inneholder bl.a. følgende tre hovedkapitler:

### 1.1.2 BESKRIVELSE

Denne delen beskriver kort ZFM's funksjon, betjening og konstruksjon.

### 1.1.3 BETJENING

Denne delen beskriver betjening og nødvendige sikkerhetstiltak.

### 1.1.4 VEDLIKEHOLD

Denne delen inneholder alle reparasjons- og vedlikeholdsoppgaver som eieren må utføre.

Begrepene «styrbord, babord, høyre, venstre», som brukes i håndboken, refererer alltid til det installerte giret i retning fremover.

Når det gjelder viktig informasjon om teknisk pålitelighet og driftssikkerhet, understrekes følgende begreper:



**ADVARSEL!**

**En drifts- eller vedlikeholdsanvisning, bruksanvisning, beskrivelse, betingelse osv., som ikke følges nøye, kan føre til personskader eller dødsfall.**



**OBS!**

**En drifts- eller vedlikeholdsanvisning, bruksanvisning, beskrivelse, betingelse osv., som ikke følges nøye, kan føre til at utstyret blir skadet eller ødelagt.**

**MERK:** Gjelder tekniske krav som brukeren spesielt må passe på.

**ADVARSEL!, OBS! og MERK:** står alltid foran den teksten det gjelder for.

## 2.1 Identifisering av giret

Identifikasjonsskiltet er festet på retningsvenderen.

På fig. 1 ser du et eksempel på et identifikasjonsskilt:

- A** Girets serienr.
  - B** Gir delenummer
  - C** Utvekslingsforhold Propell, samme rotasjon som motoren
  - D** Utvekslingsforhold Propell, motsatt rotasjon av motoren.
  - E** Hvert år blir det brukt et nytt progressivt skrifttegn.
  - F** Girtype
- Betydningen av betegnelsen på giret:
- G** Girtype
  - H** Størrelse
  - I** Girversjon

## 3.1 Beskrivelse

Propell, samme rotasjonsretning som motorens

ZF M-vendegirene er hydrauliske med rett tannhjulutveksling.

De er robuste og pålitelige. Likevel krever de at monteringen gjøres i henhold til denne anvisningen, og at brukeren overholder forskriftene for betjening og vedlikehold.

Hvis man ikke overholder dette, har man ingen garantikrav. Servicehåndboken fås hos produsenten.

Fig. 2:

- 1) Varmeveksler
- 2) Utgangsflens
- 3) Identifikasjonsskilt
- 4) Girvelgerarm
- 5) Bøyle for fjernstyring
- 6) Klokke
- 7) Inngangsaksel
- 8) Oljepeilepinne.

## 4.1 Installasjon

Når ZF Marine Arco S.p.A.'s ZF-gir monteres, må man ta hensyn til følgende punkter:

- Monteringen må kun utføres av en spesialist
- **SKRÅSTILLING** (Fig. 3): Girets posisjon i forhold til inngangsaksel må ikke overskride en vinkel på 20° (15° for ZF MIV) i kontinuerlig drift.

Tillatt sidehelning fås ved forespørsel hos produsenten.

- **KOBLINGER:** Vri elastisk kobling med radial frigang (minst 0,5 mm) er nødvendig på motorsiden.

Bøyeelastisk kobling anbefales på propellsiden.

- **MOTOR-GIR-FORBINDELSE:** (Fig.4):

- 1) Motorflens
- 2) Svinghjul
- 3) Kobling
- 4) Giraksel
- 5) Girflens
- 6) Svinghjulshus

Tillatt radial- og planavvik X: P- 0,1 mm

- **GIR-PROPELLAKSEL-FORBINDELSE** (Fig. 5 - 6):

- Velg passende kjøler

Detaljert informasjon finner du i installasjonshåndboken.

**Oljesorter:** ATF (Automatic Transmission Fluid) se kapittel 10.1.

## 5.1 Betjening

Alle ZF-girene prøvekjøres før levering.

Under normaldrift bør giret kun skiftes når motoren går på tomgangsturtall.

I nødsituasjoner kan man også skifte gir ved høyere turtall.

Hydraulikkretsen fungerer korrekt bare hvis hydraulikkvæsken skiftes ut med jevne mellomrom (se kapittel 6.1).

Visuelle kontroller av lekkasjer må foretas fra tid til annen.



**ADVARSEL!**

Arbeid på giret og propellene må kun gjennomføres når giret og propellene står stille.



**OBS!**

Før giret tas i bruk, må man fylle på girolje.

Prosedyre, oljetype, fyllmengde osv. finner du i kapittel 6.1.4.



**OBS!**

Brukes giret med for lav oljestand, resulterer det i skader på giret.

For høy oljestand kan forårsake lekkasjer på tetningene og lufteåpningen, og øke driftstemperaturen betraktelig. Vi anbefaler bruk av temperaturføler.

### 5.1.1 BETJENINGSPROSEDYRE



**OBS!**

Kontroller oljestanden før oppstart (se kapittel 6,1,1).



**OBS!**

Under normaldrift bør man kun skifte gir når motoren går på tomgangsturtall. Skifter man gir ved høyere turtall, kan det føre til overbelastning av koblingen, og bør derfor unngås under normaldrift.

**MERK:** I en nødsituasjon kan endringen av kjøreretningen, fra fremover til revers, utføres med høy motorhastighet.

### GIRSKIFETPOSISJONER (bilde 8):

A = propellrotasjon motsatt av motorrotasjon

N = tomgang (nøytral)

B = propellrotasjon i samme retning som motorrotasjon



**ADVARSEL!**

Start kun motoren i girposisjon "N" (nøytral).

Normal driftstemperatur for giret skal ligge mellom 50° C (120° F) og 80° C (176° F).

Maks.tillatte ATF oljetemperatur på 100° C (212° F) skal kun oppnås for kort tid.



**OBS!**

Hvis oljemetemperaturen er for høy, slå av motoren, kontroller giroljestanden og om oljekjøleren har riktig vanngjennomstrømning.

Ikke start motoren igjen før feilen er fjernet.

### 5.1.2 SEILING, SLEPING ELLER OPPANKRING

Når motoren er slått av og båten seiler, slepes eller er ankret opp, kan propellen rotere som følge av strømmen.

Det innebærer ingen risiko for giret.

På en båt med to motorer kan propellen til den motoren, som ikke er i bruk, gå fritt på tomgang. Når motoren er slått av, er det uvesentlig hvilken posisjon girvelgerarmen står i.



**OBS!**

Avec l'arbre d'hélice en marche à vide, le levier de commande doit être dans la position «N» (Fig. 7). Utilisez la position de commande contraire à la direction de course pour bloquer l'arbre de l'hélice, pour éviter un endommagement de la transmission.



**ADVARSEL!**

Ikke arbeid på giret når båten slepes eller er ankret opp i en elv, fordi propellen kan rotere.



**ADVARSEL!**

Ikke arbeid på giret til en båt med to motorer når en av motorene går, fordi propellen til det giret, som er slått av, kan rotere.



**ADVARSEL!**

Når motoren går på tomgang og propellakselen ikke skal drives (f.eks. når batteriet lades opp med generator), må girvelgerarmen

(bilde 7) holdes i nøytral (N), for at båten ikke skal bevege seg. En hydraulisk girkasse som står i nøytral må ikke kjøres på annet enn tomgangsturtall.

### 5.1.3 KONTROLLSYSTEMER



**OBS!**

Pass på at styrestang/kabel går lett

#### GIRVELGERARMENS BEVEGELSE:

Mod: ZF 5 M - 6 M - 10 M - 12 M - 15 M  
- 15 MA - 15 MIV - 25 M - 25 MA  
- 30 M.

Girvelgerarmens bevegelse (N-A=N-B) må minst være 35 mm for ytre dreiepunkt og 30 mm for indre dreiepunkt.

#### Fig. 8:

- 1) Klemskruer tiltreknings-moment  
22 ± 1 Nm
- 2) Minimum girarmbevegelse for styrekabelen
- 3) Ikke løsne dekselet
- 4) Bunnplugg  
Tiltrekningsmoment: Ma = 22 Nm  
(16 lb-ft).

#### GIRVELGERARMENS BEVEGELSE:

Mod: ZF 4-1 M

Girvelgerarmens bevegelse (N-A=N-B) må være 38,5±1,5 mm for ytre dreiepunkt og 33,5±1,5 mm for indre dreiepunkt, fra nøytralstilling. Når girvelgerarmen når en vinkel på 10°-12°, begynner den også å bevege seg vinkelrett utover og stopper ved endeanslag (vinkel på 40°).

#### Fig. 9:

- 1) Klemskruer tiltreknings-moment  
22 ± 1 Nm
- 2) Ikke løsne mutteren
- 3) Ikke løsne dekselet

GIRVELGERARMENS STILLING i nøytral posisjon er rettvisklet på sty-

restang/kabel. Girvelgerarmen kan festes i en hvilken som helst stilling med en klemskruer.

Avstanden girvelgerarm/deksel må være minst 0,5 mm. Når dekselet løsnes, kreves det etterjustering (kun av fagperson).

#### Fig. 10:

- 1) Oljepeilepineskruer og oljefylleskruer, 17 mm  
Tiltrekningsmoment: Ma = 20 Nm  
(15 lb-ft).
- 2) Girvelgerarmavstand min. 0,5 mm

**KONTROLLER:** For å kunne garantere korrekt funksjon er det nødvendig å kontrollere girvelgerarmen med jevne mellomrom.

## 6.1 Vedlikehold

### 6.1.1 KONTROLL AV OLJESTANDEN



**ADVARSEL!**

Vedlikeholdsarbeider på giret må kun utføres mens motoren står stille. Ha alltid hansker på når du arbeider på et varmt gir.

### BESKRIVELSE AV OLJEPEILEPINNEN (bilde 11):

- 1) Husets overflate
- 2) Peilestav
- 3) Oljenivå
- 4) ATF-olje
- 5) Tetningsskive.

Oljestanden kan kontrolleres i varm eller kald tilstand.

**MERK:** Kontroller alltid oljenivået før retningsvenderen startes opp. Gå frem som følger:

- Vri håndtaket på oljepeilepinnen (bilde 11) mot urviseren og trekk den ut.
- Tørk av peilepinnen med en ren, støvfri fille.

- Sett inn peilepinnen i boringen på huset uten å skru til, trekk den ut igjen og les av oljestanden.

Oljenivået må være mellom min.- og maks.merket på peilepinnen (3-4 bilde 11).

- Sett inn peilepinnen og skru den fast med urviseren.



**OBS!**

**Avhengig av type og innretning av kjøler og ledninger vil det samle seg en bestemt oljemengde etter at motoren er slått av.**

**Oljen vil flyte tilbake i giret ved en lengre stillstandsperiode. Dette kan føre til at oljestanden i giret overstiger maks.merket. Ikke fjern giroljen som er over maks.merket. Følg fremgangsmåten.**

- Start motoren og la motoren gå på tomgangsturtall, til kjøleren og ledningene er fylt med girolje.
- Slå av motoren og kontroller oljestanden på nytt. Etterfyll olje hvis det er nødvendig. Riktig oljestand er nådd når oljen er mellom min.- og maks.merket på peilepinnen (bilde 11). Kontroller oljen igjen etter en kort kjøretid.

### 6.1.2 OLJESKIFT



**OBS!**

**Det første oljeskiftet må foretas etter 25 driftstimer.**

**Alle senere oljeskift foretas hver 300. driftstime eller en gang i året.**



**OBS!**

**Brukt olje må beregnes som spesialavfall som forurenses miljøet. Olje skal derfor kildesorteres.**

### 6.1.3 TØMME GIROLJE

Fjern bunnpluggen (1 fig. 12) og la oljen renne ut av det dertil bestemte hullet nederst på huset.



### 6.1.4 PÅFYLLING AV GIROLJE

Fyll på med olje for ATF automatgir. Overhold mengdene som oppgis nedenfor. Fyll på nødvendig mengde for å fylle varmeveksleren og tilhørende koplingsrør.

ZF 4-1 M: .....	0,42 Liter
ZF 5 M: .....	0,42 Liter
ZF 6 M: .....	0,42 Liter
ZF 10 M: .....	0,42 Liter
ZF 12 M: .....	0,60 Liter
ZF 15 M: .....	0,60 Liter
ZF 15 MA: .....	0,56 Liter
ZF 15 MIV: .....	1,00 Liter
ZF 25 M: .....	0,75 Liter
ZF 25 MA: .....	0,75 Liter
ZF 30 M: .min. 0,90 - maks. 1,10 liter	

• Gyldig for helning av akselen under 20 grader (15° for ZF MIV).

Bruk kun olje for automatgir som spesifisert i "Listen over anbefalte oljer" på side 82.

### 6.1.5 PRØVEKJØRING

- 1) Foreta en prøvekjøring etter oljeskiftet.
  - 2) Sett girvelgerarmen i nøytral posisjon (N). Start motoren og la den gå litt på tomgang, til oljekjøleren og ledningene er fylt med girolje.
  - 3) Slå av motoren og kontroller oljestanden på nytt. Etterfyll olje hvis det er nødvendig. Pump ut overflødig olje.
- Riktig oljestand er nådd når oljen er mellom min.- og maks. merket på peilepinnen. Kontroller oljen igjen etter en kort kjøretid.

### 6.1.6 LAGRING

Hvis giret lagres i lengre tid, f.eks. om vinteren, må giret fylles opp til randen med foreskrevet ATF-girolje gjennom hullet til peilepinnen, for å beskytte den mot korrosjon.



**OBS!**

**Foreta et oljeskift når det tas i bruk igjen.**

## 7.1 Feilsøking

Sjekk først om alle forskriftene i brukerveiledningen er overholdt.

FEIL	MULIG ÅRSAK	UTBEDRING
<b>1. Høy oljetemperatur</b>	<ul style="list-style-type: none"> <li>- Oljestanden er for høy under drift</li> <li>- For lav oljestand</li> <li>- Tilstoppet kjøler, eller innskrenket vanngjennomstrømning</li> <li>- Ikke noe vann i kjølersystemet</li> </ul>	<ul style="list-style-type: none"> <li>- Pump ut olje til maks. merket på peilestaven vises</li> <li>- Etterfyll olje</li> <li>- Skift kjøleren og spyl vannledningene</li> <li>- Kontroller kjølersystemet og evt. reparer det</li> </ul>
<b>2. Olje på girhuset</b>	<ul style="list-style-type: none"> <li>- Løse skruer</li> <li>- Løse skrueforbindelser</li> <li>- Oljepeilepinnen sitter ikke fast</li> <li>- Oljestanden er for høy under drift</li> </ul>	<ul style="list-style-type: none"> <li>- Trekk til iht. spesifikasjon</li> <li>- Trekk til, skift ut</li> <li>- Skyv den inn til anslag, bytt ut</li> <li>- Pump ut olje til maks. merket på peilestaven vises</li> </ul>
<b>3. Hard å gire</b>	<ul style="list-style-type: none"> <li>- Velgerinnretningen</li> <li>- Stengene</li> </ul>	<ul style="list-style-type: none"> <li>- Rådspør reparasjonsverksted</li> <li>- Stilles inn/justeres</li> </ul>
<b>4. Girene kommer sent i inngrep</b>	<ul style="list-style-type: none"> <li>- Velgerinnretningen</li> <li>- Stengene</li> </ul>	<ul style="list-style-type: none"> <li>- Rådspør reparasjonsverksted</li> <li>- Stilles inn/justeres</li> </ul>
<b>5. Ingen bevegelse av båten</b>	<ul style="list-style-type: none"> <li>- Velgerinnretningen</li> <li>- Girvelgerarmen er ikke ordentlig i inngrep</li> <li>- Propellen er falt av</li> <li>- Propellen er brukket</li> <li>- Funksjonsfeil på giret</li> <li>- Funksjonsfeil på motoren</li> </ul>	<ul style="list-style-type: none"> <li>- Rådspør reparasjonsverksted</li> <li>- Sørg for at den går i inngrep</li> <li>- Monter ny propell</li> <li>- Rådspør reparasjonsverksted</li> <li>- Rådspør reparasjonsverksted</li> <li>- Rådspør reparasjonsverksted</li> </ul>





## 8.1 Tekniske data

### Technical Data for Pleasure Craft Duty

Based on engine power B to DIN 6270; shock factor

**K = 1.25 to be applied, if engine has 1 cylinder / K = 1.20 for 2 cylinders / K = 1.15 for 3 cylinders**

MODEL	RATIO		POWER / RPM		INPUT POWER CAPACITY						MAX RPM	WEIGHT		BELL HSGS. AND NOTES
	«A» Pos	«B»Pos	kW	hp	2800 rpm		3000 rpm		3600 rpm			kg	lb	
					kW	hp	kW	hp	kW	hp				
ZF 5 M	2.045	1.864	0.0066	0.0088	18	25	20	27	20	27	5000	8.5	19	SAE 6, B/W Max input power 20 kW
	2.722	2.150	0.0047	0.0063	13	18	14	19	17	23				

**K = 1.25 to be applied, if engine has 1 cylinder / K = 1.20 for 2 cylinders / K = 1.15 for 3 cylinders**

MODEL	RATIO		POWER / RPM		INPUT POWER CAPACITY						MAX RPM	WEIGHT		BELL HSGS. AND NOTES
	«A» Pos	«B»Pos	kW	hp	2800 rpm		3000 rpm		3600 rpm			kg	lb	
					kW	hp	kW	hp	kW	hp				
ZF 6 M	2.045	1.864	0.0066	0.0088	18	25	20	27	20	27	5000	10.3	23	SAE 4, 5, 6, B/W Max input power 20 kW
	2.722	2.150	0.0047	0.0063	13	18	14	19	17	23				

**K = 1.25 to be applied, if engine has 1 cylinder / K = 1.20 for 2 cylinders / K = 1.15 for 3 cylinders**

\*\* Max. 95 Nm (70 ft lb) admissible for main travelling direction with gear lever set to «B»

MODEL	RATIO		POWER / RPM		INPUT POWER CAPACITY						MAX RPM	WEIGHT		BELL HSGS. AND NOTES
	«A» Pos	«B»Pos	kW	hp	2800 rpm		3000 rpm		3600 rpm			kg	lb	
					kW	hp	kW	hp	kW	hp				
ZF 10 M	1.482	1.864	0.0109	0.0146	30	41	33	44	38	51	5000	10.3	23	SAE 4, 5, 6, B/W Max input power 38 kW. <b>Ratio 1.482 «B» Pos. max torque 95 Nm. Ratio 1.792 «B» Pos. max torque 95 Nm.</b>
	1.792	1.864												
	2.045	1.864												
	2.722	2.150												

**K = 1.25 to be applied, if engine has 1 cylinder / K = 1.20 for 2 cylinders / K = 1.15 for 3 cylinders**

MODEL	RATIO		POWER / RPM		INPUT POWER CAPACITY						MAX RPM	WEIGHT		BELL HSGS. AND NOTES
	«A» Pos	«B»Pos	kW	hp	2800 rpm		3000 rpm		3600 rpm			kg	lb	
					kW	hp	kW	hp	kW	hp				
ZF 12 M	2.136	1.955	0.0131	0.0176	37	49	39	53	47	63	5000	13	29	SAE 4, 5, 6, B/W, Yanmar JH Max input power 55 kW
	2.632	1.955	0.0111	0.0149	31	42	33	45	40	54				

**K = 1.25 to be applied, if engine has 1 cylinder / K = 1.20 for 2 cylinders / K = 1.15 for 3 cylinders**

\*\* Max. 120 Nm (88.5 ft lb) admissible for main travelling direction with gear lever set to «B»

MODEL	RATIO		POWER / RPM		INPUT POWER CAPACITY						MAX RPM	WEIGHT		BELL HSGS. AND NOTES
	«A» Pos	«B»Pos	kW	hp	3000 rpm		3600 rpm		3800 rpm			kg	lb	
					kW	hp	kW	hp	kW	hp				
ZF 15 M	1.556	1.955	0.0152	0.0204	46	61	55	73	55	74	5000	13	29	SAE 4, 5, 6, B/W, Yanmar JH Max input power 55 kW. <b>Ratio 1.556 «B» Pos. max torque 120 Nm. Ratio 1.875 «B» Pos. max torque 120 Nm.</b>
	1.875	1.955												

«A» POS = continuous running position (normally AHEAD).

«B» POS = reverse position.

B/W = Borg Warner adaptor.

Note = For all «M» (Mechanical) transmissions reduce power capacity by the following shock factors: 1 cylinder engine ÷ 1.25, 2 cylinder engine ÷ 1.20, 3 cylinder engine ÷ 1.15.



**K = 1.25 to be applied, if engine has 1 cylinder / K = 1.20 for 2 cylinders / K = 1.15 for 3 cylinders**

\*\* Max. 120 Nm (88.5 ft lb) admissible for main travelling direction with gear lever set to «B»

MODEL	RATIO		POWER / RPM		INPUT POWER CAPACITY						MAX RPM	WEIGHT		BELL HSGS. AND NOTES
	«A» Pos	«B»Pos	kW	hp	3000 rpm		3600 rpm		3800 rpm			kg	lb	
					kW	hp	kW	hp	kW	hp				
ZF 15 MA 8 degrees	1.875	1.955	0.0152	0.0204	46	61	55	73	55	74	5000	13.5	30	SAE 4, 5, 6, B/W, Yanmar JH Max input power 55 kW. <b>Ratio 1.875 «B» Pos. max torque 120 Nm. Ratio 2.136 «B» Pos. max torque 120 Nm.</b>
	2.136	1.955	0.0131	0.0176	39	53	47	63	50	67				
	2.632	1.955	0.0111	0.0149	33	45	40	54	42	57				

**K = 1.25 to be applied, if engine has 1 cylinder / K = 1.20 for 2 cylinders / K = 1.15 for 3 cylinders**

\* Max. 120 Nm (88.5 ft lb) admissible for main travelling direction with gear lever set to «B».

\*\* Max 45 kW for main travelling direction with gear lever set to «B».

MODEL	RATIO		POWER / RPM		INPUT POWER CAPACITY						MAX RPM	WEIGHT		BELL HSGS. AND NOTES
	«A» Pos	«B»Pos	kW	hp	3000 rpm		3600 rpm		3800 rpm			kg	lb	
					kW	hp	kW	hp	kW	hp				
ZF 15 MIV 8 degrees	2.134	2.224	0.0152	0.0204	46	61	55	73	55	74	5000	21	47	SAE 4, 5, B/W, Yanmar JH Max input power 55 kW. <b>Ratio 2.134 «B» Pos. max torque 120 Nm.</b>
	2.718	2.224	0.0111	0.0149	33	45	40	54	42	57				
	2.995	2.224												

**K = 1.25 to be applied, if engine has 1 cylinder - K = 1.20 for 2 cylinders - K = 1.15 for 3 cylinders**

\*\* Max. 230 Nm (170 ft lb) admissible for main travelling direction with gear lever set to «B»

MODEL	RATIO		POWER / RPM		INPUT POWER CAPACITY						MAX RPM	WEIGHT		BELL HSGS. AND NOTES
	«A» Pos	«B»Pos	kW	hp	3000 rpm		3600 rpm		3800 rpm			kg	lb	
					kW	hp	kW	hp	kW	hp				
ZF 25 M	1.880	2.095	0.0262	0.0351	79	105	80	107	80	107	5000	18.5	41	SAE 4, 5, B/W, Yanmar JH Max input power 80 kW. <b>Ratio 1.880 «B» Pos. max torque 230 Nm.</b>
	2.273	2.095	0.0216	0.0289	65	87	78	104	80	107				
	2.737	2.722	0.0177	0.0237	53	71	64	85	67	90				

**K = 1.25 to be applied, if engine has 1 cylinder / K = 1.20 for 2 cylinders / K = 1.15 for 3 cylinders**

\*\* Max. 169 Nm (125 ft lb) admissible for main travelling direction with gear lever set to «B»

MODEL	RATIO		POWER / RPM		INPUT POWER CAPACITY						MAX RPM	WEIGHT		BELL HSGS. AND NOTES
	«A» Pos	«B»Pos	kW	hp	3000 rpm		3600 rpm		3800 rpm			kg	lb	
					kW	hp	kW	hp	kW	hp				
ZF 25 MA 8 degrees	2.227	2.737	0.0215	0.0288	64	86	77	104	80	107	5000	21.1	47	SAE 4, 5, B/W, Yanmar JH Max input power 80 kW. <b>Ratio 2.227 «B» Pos. max torque 169 Nm.</b>
	2.737	2.737	0.0177	0.0237	53	71	64	85	67	90				

**K = 1.25 to be applied, if engine has 1 cylinder / K = 1.20 for 2 cylinders / K = 1.15 for 3 cylinders**

\*\* Max. 185 Nm (137 ft lb) admissible for main travelling direction with gear lever set to «B»

MODEL	RATIO		POWER / RPM		INPUT POWER CAPACITY						MAX RPM	WEIGHT		BELL HSGS. AND NOTES
	«A» Pos	«B»Pos	kW	hp	3000 rpm		3600 rpm		3800 rpm			kg	lb	
					kW	hp	kW	hp	kW	hp				
ZF 30 M	2.148	2.636	0.0241	0.0323	72	97	87	116	92	123	5000	23	51	4 & 5 Yanmar JH Max input power 95 kW. <b>Ratio 2.148 «B» Pos. max torque 185 Nm. Ratio 2.696 «B» Pos. max torque 185 Nm.</b>
	2.696	2.636												

«A» POS = continuous running position (normally AHEAD).

«B» POS = reverse position.

B/W = Borg Warner adaptor.

Note = For all «M» (Mechanical) transmissions reduce power capacity by the following shock factors: 1 cylinder engine ÷ 1.25, 2 cylinder engine ÷ 1.20, 3 cylinder engine ÷ 1.15.

## 9.1 Garanti

### 9.1.1 GARANTIVILKÅR

ZF Marine Arco S.p.A. garanterer at ZFM vendegir er fritt for mangler når det gjelder materiale og bearbeiding ved normalt bruk og vedlikehold, med forbehold om at garantien kun gjelder dersom utstyret er blitt riktig installert og drevet. Forpliktelsen til ZF Marine Arco S.p.A. under denne garantien er begrenset til, etter eget valg, å skifte ut eller reparere samtlige deler, som ZF Marine Arco S.p.A. har undersøkt og fastslått er defekte, dersom delen eller delene returneres til nærmeste forhandler av ZF Marine Arco S.p.A., betalt for frakt og innen fristen:

Tjuefire (24) måneder fra leveringsdato til kunden og trettiseks (36) måneder fra leveringsdato til motorprodusenten, hva som enn inntreer først.

ZF Marine Arco S.p.A.'s forpliktelser under denne garantien gjelder med forbehold om at forhandleren eller motorprodusenten, som har kjøpt produktet, har oppfylt garantiprosedyrene, som utgjør en del av denne kontrakten.

Samtlige garantikrav skal forelegges for forhandlerne og motorprodusentene, som har kjøpt giret. Denne garantien gjelder ikke de delene som er blitt reparert eller modifisert uten skriftlig tillatelse fra en autorisert ZF Marine Arco S.p.A.-forhandler.

Denne garantien gjelder ikke hvis produktet eller en av komponentene eller

delene er blitt gjenstand for misbruk, uforsiktighet, modifisering eller uhell, eller ikke er drevet i henhold til de trykte instruksjonene fra ZF Marine Arco S.p.A., eller er drevet under betingelser som er hardere eller på annen måte overskrider betingelsene som er fastlagt for dette produktet i spesifikasjonene, eller ikke er blitt forskriftsmessig installert eller blitt bygd inn igjen, eller feilaktig vedlikeholdt eller drevet.

Denne garantien går foran andre uttrykkelige eller impliserte garantier, inklusive de for lettselgelig kvalitet og dugelighet ved bruk, samt alle andre forpliktelser, bl.a. inkl. indirekte følgeskader. ZF Marine Arco S.p.A. overtar ingen ytterligere forpliktelser i forbindelse med salg av giret, og ZF Marine Arco S.p.A. gir heller ingen personer i oppdrag å overta noen slik forpliktelse. ZF Marine Arco S.p.A. er ikke under noen omstendigheter ansvarlig for noe garantibrudd på et beløp som ligger over innkjøpsprisen av giret.

### 9.1.2 TORSJONSANSVAR OG TORSJONS KOPLINGER (DEMPERPLATER).

Ansvar for å sikre torsjons forenlighet påhviler den som bygger sammen den drivende og det drevne utstyr.

ZF kan ikke akseptere noe ansvar for girkassestøy forårsaket av svingninger eller vibrasjoner eller for skader i

og på girkassen, den fleksible koplingen eller til andre deler av drivenheten forårsaket av denne type svingninger. Kontakt ZF Marine Arco S.p.A. for videre informasjon og assistanse.

ZF Marine Arco S.p.A. anbefaler å bruke et torsjons anslag for singel motoriserte båter, hvori tap av drivkraft kan forårsake at båten kommer ut av kontroll.

Det er kjøpers ansvar å spesifisere dette valg, som kan medføre en tilleggskostnad og en mulig økning i installasjonslengde.

ZF Marine Arco S.p.A. kan ikke akseptere noe ansvar for personskade, tap av liv eller ødeleggelse av eiendom grunnet i feil som følge av at kjøper ikke har spesifisert et torsjonsanslag. ZF Marine Arco S.p.A. velger torsjonskoplinger (demperplater) på basis av pålydende (nominelt) inngående motormoment og det vanligvis aksepterte og fastsatte motorturtall.

Konsultér ZF Marine Arco S.p.A. for detaljer vedrørende turtallsbegrensninger på standard torsjonskoplinger (demperplater), som kan være lavere enn girkassens spesifikasjon.

Spesielle torsjonskoplinger (demperplater) kan bli nødvendig for å imøtekomme (Survey SAociety Ice Classification) klassing selskapenes krav for å gå i is.

# PORTUGUÊS

## Contido

1.1	Introdução .....	47
2.1	Identificação do Reversor.....	47
3.1	Descrição .....	47
4.1	Instalação .....	47
5.1	Operação.....	48
6.1	Manutenção.....	49
7.1	Problemas e soluções.....	50
8.1	Dados Técnicos.....	51
9.1	Garantia.....	53
10.1	Lista de fluidos recomendados.....	82
11.1	Lista de concessionários.....	83
12.1	Desenhos de instalação.....	84
13.1	Warranty Card .....	95

## 1.1 Introdução

### 1.1.1 RESPONSABILIDADE DO CLIENTE

O Cliente/Usuário é responsável por efetuar as verificações de segurança necessárias para assegurar que a lubrificação, o arrefecimento, a manutenção e as práticas recomendadas no presente manual sejam cumpridas estritamente a fim de proporcionar o funcionamento correto e com total segurança do reversor.

Cada unidade reversora está coberta por uma garantia, portanto: Para que a mesma seja válida, as instruções relativas ao reversor mencionadas neste manual deverão ser rigorosamente seguidas.



#### ATENÇÃO

**O fabricante não se responsabiliza por quaisquer danos ou prejuízos causados por instalação inadequada, operação incorreta e/ou manutenção insuficiente do equipamento.**

**O Cliente deve se certificar de que sejam evitadas toda e qualquer força externa ou vibração causada por torção e flexão.**

**A interação entre o motor, o eixo e a hélice pode ocasionar vibração por torção, produzindo um ruído constante de impacto das engrenagens, capaz de danificar o motor e/ou o reversor.**

**O Fornecedor não pode ser responsabilizado por tal vibração causada por torção inerente à instalação.**

Este manual inclui, entre outras coisas, os seguintes três capítulos principais:

### 1.1.2 DESCRIÇÃO

Esta parte descreve brevemente a função, a operação e os principais componentes do reversor ZF M.

### 1.1.3 OPERAÇÃO

Esta parte descreve os procedimentos de operação e todas as medidas de segurança necessárias.

### 1.1.4 MANUTENÇÃO

Esta parte contém todas as tarefas de manutenção e de serviço que o usuário deve efetuar.

Os termos “esquerdo, direito, bombordo e estibordo” utilizados neste manual se referem sempre a reversores instalados com direção de marcha à frente. As informações importantes referentes à confiabilidade técnica e à segurança de operação são evidenciadas da seguinte maneira:



#### PERIGO

**Todos os procedimentos, práticas, condições e recomendações, etc., que não forem respeitados rigorosamente, podem causar ferimentos ou morte de pessoas.**



#### ATENÇÃO

**Todos os procedimentos, práticas, condições e recomendações, etc., que não forem respeitados rigorosamente, podem danificar ou destruir o equipamento.**

**NOTA:** Refere-se a aspectos técnicos aos quais o usuário do equipamento deve prestar particular Atenção.

**PERIGO, ATENÇÃO e NOTA** sempre precedem o texto ao qual se referem.

## 2.1 Identificação do Reversor

A placa de identificação está aplicada no inversor.

A Fig. 1 mostra um exemplo de placa de identificação:

- A** Número de série do reversor
- B** Código de peça do reversor
- C** Relação de transmissão para hélice que gira na mesma direção do motor.

**D** Relação de transmissão para hélice que gira em direção oposta à do motor.

**E** A cada ano uma nova letra é designada em ordem crescente.

**F** Tipo de reversor  
Significado dos códigos da transmissão:

**G** Tipo de reversor

**H** Tamanho da transmissão

**I** Versão da transmissão

## 3.1 Descrição

Os reversores marítimos ZF M são transmissões de engrenagens helicoidais comandadas por um mecanismo automático.

Eles se distinguem por sua construção robusta e extrema confiabilidade. Apesar disso, aconselhamos que o usuário observe rigorosamente as seguintes instruções para sua instalação, operação e manutenção.

O não cumprimento das instruções contidas neste manual, ou toda modificação não autorizada do reversor, invalidará toda e qualquer solicitação de garantia.

Mediante pedido, o fabricante poderá fornecer um Manual de Reparação.

Fig. 2:

- 1) Radiador de óleo
- 2) Flange de saída
- 3) Placa de identificação
- 4) Alavanca de comando.
- 5) Estribo de comando à distância.
- 6) Campânula.
- 7) Eixo de entrada
- 8) Vareta de medição

## 4.1 Instalação

Ao instalar um reversor ZFM, é necessário seguir rigorosamente as seguintes indicações:

- A instalação deve ser efetuada somente por pessoal especializado.
- **POSIÇÃO INCLINADA:** (Fig. 3): A posição da transmissão, relativamente ao eixo de entrada, não deve exceder um ângulo de 20° (15° para ZF MIV), durante o funcionamento contínuo. Em referência à inclinação lateral permitida, entre em contato com o fabricante.
- **ACOPLAMENTOS:** É necessário instalar um acoplamento elástico à torção com folga radial mínima (0,5 mm) entre o motor e o reversor.



É recomendável instalar um acoplamento elástico flexível entre o reversor e o eixo da hélice.

• **CONEXÃO MOTOR-REVERSOR** (Fig. 4):

- 1) Flange do motor
- 2) Volante
- 3) Acoplamento elástico
- 4) Eixo do reversor
- 5) Flange do reversor
- 6) Alojamento do volante

Excentricidade máxima admissível, radial e axial X: B - 0,1 mm

• **CONEXÃO REVERSOR - EIXO DA HÉLICE** (Fig. 5 - 6):

• Instale um radiador de óleo adequado. Para mais informações, consulte o manual de instalação.

**Tipo de óleo:** ATF (fluido para transmissão automática). Veja o capítulo 10.1.

## 5.1 Operação

Todas as transmissões passam por um teste de funcionamento antes do embarque.

Em condições normais de funcionamento, a reversão de marcha somente deverá ser efetuada com o motor em marcha-lenta. Em caso de emergência, a reversão em rotações mais altas também é admissível.

O funcionamento correto do circuito hidráulico só é garantido se o fluido hidráulico for trocado regularmente, conforme indicado na manutenção programada. (Consulte o capítulo 6.1). Periodicamente, faça uma inspeção visual à procura de eventuais vazamentos de óleo.



### PERIGO

Somente efetue serviços no reversor com o motor desligado e a hélice parada.



### ATENÇÃO

Antes da colocação em marcha, o reversor deverá ser abastecido com o fluido de transmissão indicado. Para o procedimento de abastecimento, tipo, quantidade e nível de fluido, e para a troca do fluido, veja capítulo 6.1.4.



### ATENÇÃO

O uso do reversor com uma quantidade insuficiente de óleo danificará

as engrenagens. Uma quantidade excessiva de óleo pode causar vazamentos pelos retentores dos eixos e respiro, além de causar um aumento excessivo da temperatura de funcionamento.

### 5.1.1 PROCEDIMENTO DE OPERAÇÃO



#### ATENÇÃO

Antes de colocar o reversor em funcionamento, verifique o nível do óleo (veja o capítulo 6.1.1).



#### ATENÇÃO

Em condições normais, a alavanca de comando somente deve ser acionada com o motor em marcha-lenta. As reversões efetuadas em uma rotação mais elevada podem provocar uma sobrecarga dos discos da embreagem e devem ser evitadas durante o funcionamento normal.

**NOTA:** Em caso de emergência é possível efetuar a reversão, de marcha à frente a marcha à ré, com o motor em alta rotação.

#### POSIÇÕES DE COMANDO (Fig. 7):

A = Direção de rotação da hélice oposta à do motor.

N = Posição neutra

B = Direção de rotação da hélice igual à do motor.



#### PERIGO

Somente dê partida no motor com a alavanca de comando na posição neutra.

A temperatura normal de trabalho do óleo do reversor deve permanecer entre 50°C (122°F) e 80°C (176°F). A temperatura máxima de 100°C (212°F) admissível para o óleo ATF somente pode ser mantida durante um curto período.



#### ATENÇÃO

Caso a temperatura do fluido se eleve excessivamente, desligue o motor imediatamente, verifique o nível do fluido no reversor e assegure-se quanto ao fluxo correto de água no radiador de óleo. Não dê partida novamente no motor sem

primeiro eliminar a causa do mau funcionamento.

### 5.1.2 NAVEGAÇÃO À VELA, REBOQUE OU ANCORAGEM

Quando o motor está desligado e a embarcação navega à vela, independentemente dela estar sendo rebocada ou estar ancorada, a hélice pode rodar pelo efeito da corrente. Isso não danifica o reversor. Em uma embarcação com dois motores, quando somente um deles funciona, a hélice do reversor não utilizado pode girar livremente.

Quando o motor está desligado, a posição da alavanca de comando é irrelevante.



#### ATENÇÃO

Com o eixo da hélice em posição neutra, a alavanca de comando deverá estar na posição «N» (Fig.7). Utilize a posição de comando contrária à de deslocamento a fim de travar o eixo da hélice. Caso contrário, o reversor será danificado.



#### PERIGO

Não efetue nenhum serviço no reversor durante o reboque ou com a embarcação ancorada em um rio, já que a hélice poderá girar.



#### PERIGO

Não efetue nenhum serviço no reversor de uma embarcação de motorização dupla quando um dos motores estiver ligado. O eixo da hélice do reversor inoperante irá girar.



#### PERIGO

Quando o motor gira em marcha-lenta e se deseja que a hélice não gire (por exemplo, ao carregar a bateria com o gerador), a alavanca de comando (Fig. 7) deverá ser mantida na posição neutra (N) para evitar que a embarcação se movimente. Evite utilizar o reversor hidráulico em neutro com altas rotações do motor durante um período prolongado.



### 5.1.3 SISTEMA DE COMANDO



#### ATENÇÃO

Assegure-se que a haste ou cabo de comando se movam livremente.

#### CURSO ÚTIL DA ALAVANCA:

Mod: **ZF 5 M - 6 M - 10 M - 12 M - 15 M - 15 MA - 15 MIV - 25 M - 25 MA - 30 M.**

O curso útil mínimo (N-A=N-B) da alavanca de comando deve ser de 35 mm para o orifício posicionador externo e de 30 mm para o orifício posicionador interno.

#### Fig. 8:

- 1) Torque dos parafusos de fixação da alavanca  $22 \pm 1$  Nm
- 2) Corsa mínima per il cavo di comando.
- 3) **Não** abra a tampa de comando
- 4) Bujão de drenagem de óleo  
Torque de aperto: Ma = 22 Nm (16 lb-ft).

#### CURSO ÚTIL DA ALAVANCA:

Mod: **ZF 4-1 M**

O curso útil mínimo (N-A=N-B) da alavanca de comando deve ser de  $38,5 \pm 1,5$  mm para o orifício posicionador externo e de  $33,5 \pm 1,5$  mm para o orifício posicionador interno, a partir da posição neutra. A partir da posição neutra, após girar por um ângulo de  $10^\circ$ - $12^\circ$ , a alavanca começa a se mover para fora perpendicularmente e pára ao final do curso (ângulo de  $40^\circ$ ).

#### Fig. 9:

- 1) Torque dos parafusos de fixação da alavanca  $22 \pm 1$  Nm
- 2) Não afrouxe a porca
- 3) **Não** abra a tampa de comando

**POSIÇÃO DA ALAVANCA:** Na posição neutra, ela permanece em posição perpendicular à haste ou cabo de comando. A alavanca de comando poderá ser girada e fixada em qualquer posição por meio do parafuso de fixação. A distância mínima entre a alavanca de mudança e a tampa deve ser de 0,5 mm. Caso os parafusos sejam afrouxados ou a tampa removida, será necessário um novo ajuste (a ser efetuado somente por pessoal autorizado).

#### Fig. 10:

- 1) Vareta medidora e tampa do gargalo de abastecimento de óleo (17 mm)  
Torque de aperto: Ma = 20 Nm (15 lb-ft).
- 2) Folga mínima da alavanca de comando 0,5 mm

**CONTROLES:** visando garantir o bom funcionamento, é necessário controlar a posição da alavanca regularmente.

## 6.1 Manutenção

### 6.1.1 VERIFICAÇÃO DO NÍVEL DE FLUIDO



#### PERIGO

**Não efetue nenhum serviço no reversor durante o reboque ou com a embarcação ancorada em um rio, já que a hélice poderá girar.**

#### DESCRIÇÃO DA VARETA DE MEDIÇÃO (Fig. 11):

- 1) Superfície do alojamento
- 2) Vareta de medição
- 3) Nível de óleo
- 4) Óleo ATF
- 5) Arruela de vedação.

O nível de óleo do reversor pode ser verificado a frio ou a quente.

**NOTA:** Controle sempre o nível de óleo antes de pôr o inversor a funcionar procedendo conforme indicado a seguir.

- Remova a vareta de medição (Fig. 11) girando-a em sentido anti-horário.
- Limpe a vareta com um pano limpo e sem pó.
- Coloque a vareta sem parafusá-la. Retire-a e verifique se o nível do óleo se encontra entre as marcas de mínimo e de máximo (3-4Fig. 11).
- Introduza novamente a vareta e parafuse-a girando em sentido horário.



#### ATENÇÃO

**Ao desligar o motor, o óleo presente no circuito hidráulico começará a fluir para o reversor; essa quantidade depende do tipo de radiador e circuito hidráulico usados para o arrefecimento. Depois de certo tempo, isso aumentará o nível de óleo no reversor. Não retire o excesso de óleo, mas proceda de acordo com os itens.**

- Mantenha o motor em marcha-lenta com a alavanca de comando na posição neutra até que o radiador de óleo e os tubos do circuito hidráulico tenham se preenchido de óleo.
- Desligue o motor e, em seguida, verifique o nível do óleo. Se necessário, complete o nível até ficar entre as marcas de máximo e mínimo da vareta de medição (Fig. 11). Repita a operação depois de um breve período de funcionamento.

### 6.1.2 TROCA DO ÓLEO



#### ATENÇÃO

**A primeira troca de óleo deve ser efetuada depois de 25 horas de funcionamento.**

Todas as trocas de óleo posteriores deverão ser efetuadas a cada 300 horas de funcionamento ou um ano, o que ocorrer primeiro.



#### ATENÇÃO

**O lubrificante usado deve ser tratado como resíduo especial que polui o ambiente; portanto, deve ser eliminado em função da sua estrutura diferenciada.**

### 6.1.3 DRENAGEM DO ÓLEO

Remova o bujão (1 Fig. 12) e deixe o óleo escoar pelo furo próprio situado na parte inferior da caixa.

### 6.1.4 ABASTECIMENTO COM ÓLEO ATF

Encha com óleo para caixas de velocidades automáticas ATF respeitando as quantidades indicadas a seguir. Acrescente a quantidade que considera necessária para o enchimento do permutador de calor e dos respectivos tubos de ligação.

ZF 4-1 M: .....	0,42 litros
ZF 5 M: .....	0,42 litros
ZF 6 M: .....	0,42 litros
ZF 10 M: .....	0,42 litros
ZF 12 M: .....	0,60 litros
ZF 15 M: .....	0,60 litros
ZF 15 MA: .....	0,56 litros
ZF 15 MIV: .....	1,00 litros
ZF 25 M: .....	0,75 litros
ZF 25 MA: .....	0,75 litros
ZF 30 M: mín. 0,90 - máx. 1,10 litros	

- Válido para inclinação do eixo inferior a 20 graus ( $15^\circ$  para ZF MIV).

Use exclusivamente óleo para caixas de velocidades automáticas, conforme especificações indicadas na «Lista de óleos recomendados» na pág. 82.

### 6.1.5 TESTE DE FUNCIONAMENTO

- 1) Efetue um teste de funcionamento depois da troca de óleo.
- 2) Coloque a alavanca de comando na posição neutra (N). Dê partida no motor e mantenha-o em marcha-lenta durante um breve período até

que o radiador de óleo e o circuito hidráulico sejam preenchidos com óleo.

- 3) Desligue o motor e verifique novamente o nível de óleo. Se necessário, complete o nível. O óleo em excesso deverá ser eliminado. O nível na vareta de medição deve se encontrar entre as marcas min. e máx. Verifique novamente o nível de óleo depois de um breve período de utilização.

### 6.1.6 ARMAZENAMENTO

Se o reversor for armazenado durante um longo período durante o inverno, por exemplo, ele deverá ser preenchido completamente com óleo ATF através do orifício do alojamento da vareta de medição a fim de proteger o conjunto contra a corrosão.



#### ATENÇÃO

**Troque o óleo quando o reversor for colocado novamente em funcionamento.**

## 7.1 Problemas e soluções

Antes de qualquer verificação, certifique-se de que todas as instruções indicadas tenham sido cumpridas.

SINTOMA	POSSÍVEL CAUSA	SOLUÇÃO
1. Alta temperatura do óleo	<ul style="list-style-type: none"> <li>- Nível de óleo demasiado alto durante o funcionamento</li> <li>- Nível baixo de óleo</li> <li>- Obstrução ou restrição</li> <li>- Falta de água no sistema de arrefecimento</li> </ul>	<ul style="list-style-type: none"> <li>- Remova o excesso de óleo até alcançar a marca máx. da vareta de medição</li> <li>- Adicione óleo</li> <li>- Substitua o resfriador e limpe o sistema de água do resfriador de óleo</li> <li>- Verifique e repare o sistema de arrefecimento</li> </ul>
2. Presença de óleo no alojamento do reversor	<ul style="list-style-type: none"> <li>- Parafusos frouxos</li> <li>- Conexões frouxas</li> <li>- Vareta de medição do óleo frouxa</li> <li>- Nível de óleo alto durante o funcionamento</li> </ul>	<ul style="list-style-type: none"> <li>- Aperte no torque especificado</li> <li>- Aperte ou substitua</li> <li>- Aperte ou substitua</li> <li>- Remova o excesso de óleo até alcançar a marca máx. da vareta de medição</li> </ul>
3. Dificuldade de comando	<ul style="list-style-type: none"> <li>- Comando do seletor</li> <li>- Comando remoto</li> </ul>	<ul style="list-style-type: none"> <li>- Consulte a assistência técnica</li> <li>- Efetue a regulagem</li> </ul>
4. Engate demorado	<ul style="list-style-type: none"> <li>- Comando do seletor</li> <li>- Comando remoto</li> </ul>	<ul style="list-style-type: none"> <li>- Consulte a assistência técnica</li> <li>- Efetue a regulagem</li> </ul>
5. A embarcação não se move	<ul style="list-style-type: none"> <li>- Comando do seletor</li> <li>- Posição incorreta do seletor</li> <li>- Perda da hélice</li> <li>- Ruptura do eixo da hélice</li> <li>- Falha no reversor</li> <li>- Falha no motor</li> </ul>	<ul style="list-style-type: none"> <li>- Consulte a assistência técnica</li> <li>- Efetue a regulagem</li> <li>- Substitua</li> <li>- Consulte a assistência técnica</li> <li>- Consulte a assistência técnica</li> <li>- Consulte a assistência técnica</li> </ul>

## 8.1 Dados técnicos

### Technical Data for Pleasure Craft Duty

Based on engine power B to DIN 6270; shock factor

**K = 1.25 to be applied, if engine has 1 cylinder / K = 1.20 for 2 cylinders / K = 1.15 for 3 cylinders**

MODEL	RATIO		POWER / RPM		INPUT POWER CAPACITY						MAX RPM	WEIGHT		BELL HSGS. AND NOTES
	«A» Pos	«B»Pos	kW	hp	2800 rpm		3000 rpm		3600 rpm			kg	lb	
					kW	hp	kW	hp	kW	hp				
ZF 5 M	2.045	1.864	0.0066	0.0088	18	25	20	27	20	27	8.5	19	SAE 6, B/W Max input power 20 kW	
	2.722	2.150	0.0047	0.0063	13	18	14	19	17	23				5000

**K = 1.25 to be applied, if engine has 1 cylinder / K = 1.20 for 2 cylinders / K = 1.15 for 3 cylinders**

MODEL	RATIO		POWER / RPM		INPUT POWER CAPACITY						MAX RPM	WEIGHT		BELL HSGS. AND NOTES
	«A» Pos	«B»Pos	kW	hp	2800 rpm		3000 rpm		3600 rpm			kg	lb	
					kW	hp	kW	hp	kW	hp				
ZF 6 M	2.045	1.864	0.0066	0.0088	18	25	20	27	20	27	10.3	23	SAE 4, 5, 6, B/W Max input power 20 kW	
	2.722	2.150	0.0047	0.0063	13	18	14	19	17	23				5000

**K = 1.25 to be applied, if engine has 1 cylinder / K = 1.20 for 2 cylinders / K = 1.15 for 3 cylinders**

\*\* Max. 95 Nm (70 ft lb) admissible for main travelling direction with gear lever set to «B»

MODEL	RATIO		POWER / RPM		INPUT POWER CAPACITY						MAX RPM	WEIGHT		BELL HSGS. AND NOTES
	«A» Pos	«B»Pos	kW	hp	2800 rpm		3000 rpm		3600 rpm			kg	lb	
					kW	hp	kW	hp	kW	hp				
ZF 10 M	1.482	1.864	0.0109	0.0146	30	41	33	44	38	51	10.3	23	SAE 4, 5, 6, B/W Max input power 38 kW. <b>Ratio 1.482 «B» Pos.</b> <b>max torque 95 Nm. Ratio</b> <b>1.792 «B» Pos. max</b> <b>torque 95 Nm.</b>	
	1.792	1.864												
	2.045	1.864	0.0095	0.0128	27	36	29	38	34	46				5000
	2.722	2.150	0.0068	0.0091	19	26	20	27	25	33				5000

**K = 1.25 to be applied, if engine has 1 cylinder / K = 1.20 for 2 cylinders / K = 1.15 for 3 cylinders**

MODEL	RATIO		POWER / RPM		INPUT POWER CAPACITY						MAX RPM	WEIGHT		BELL HSGS. AND NOTES
	«A» Pos	«B»Pos	kW	hp	2800 rpm		3000 rpm		3600 rpm			kg	lb	
					kW	hp	kW	hp	kW	hp				
ZF 12 M	2.136	1.955	0.0131	0.0176	37	49	39	53	47	63	13	29	SAE 4, 5, 6, B/W, Yanmar JH Max input power 55 kW	
	2.632	1.955												0.0111

**K = 1.25 to be applied, if engine has 1 cylinder / K = 1.20 for 2 cylinders / K = 1.15 for 3 cylinders**

\*\* Max. 120 Nm (88.5 ft lb) admissible for main travelling direction with gear lever set to «B»

MODEL	RATIO		POWER / RPM		INPUT POWER CAPACITY						MAX RPM	WEIGHT		BELL HSGS. AND NOTES
	«A» Pos	«B»Pos	kW	hp	3000 rpm		3600 rpm		3800 rpm			kg	lb	
					kW	hp	kW	hp	kW	hp				
ZF 15 M	1.556	1.955	0.0152	0.0204	46	61	55	73	55	74	13	29	SAE 4, 5, 6, B/W, Yanmar JH Max input power 55 kW. <b>Ratio 1.556 «B» Pos.</b> <b>max torque 120 Nm.</b> <b>Ratio 1.875 «B» Pos.</b> <b>max torque 120 Nm.</b>	
	1.875	1.955												

«A» POS = continuous running position (normally AHEAD).

«B» POS = reverse position.

B/W = Borg Warner adaptor.

Note = For all «M» (Mechanical) transmissions reduce power capacity by the following shock factors: 1 cylinder engine ÷ 1.25, 2 cylinder engine ÷ 1.20, 3 cylinder engine ÷ 1.15.



## Manual de Operação ZF 4-1 M / ZF 30 M

**K = 1.25 to be applied, if engine has 1 cylinder / K = 1.20 for 2 cylinders / K = 1.15 for 3 cylinders**

\*\* Max. 120 Nm (88.5 ft lb) admissible for main travelling direction with gear lever set to «B»

MODEL	RATIO		POWER / RPM		INPUT POWER CAPACITY						MAX RPM	WEIGHT		BELL HSGS. AND NOTES
	«A» Pos	«B»Pos	kW	hp	kW	hp	kW	hp	kW	hp		kg	lb	
					3000 rpm	3600 rpm	3800 rpm							
ZF 15 MA 8 degrees	1.875	1.955	0.0152	0.0204	46	61	55	73	55	74	5000	13.5	30	SAE 4, 5, 6, B/W, Yanmar JH Max input power 55 kW. <b>Ratio 1.875 «B» Pos. max torque 120 Nm. Ratio 2.136 «B» Pos. max torque 120 Nm.</b>
	2.136	1.955	0.0131	0.0176	39	53	47	63	50	67	5000			
	2.632	1.955	0.0111	0.0149	33	45	40	54	42	57	5000			

**K = 1.25 to be applied, if engine has 1 cylinder / K = 1.20 for 2 cylinders / K = 1.15 for 3 cylinders**

\* Max. 120 Nm (88.5 ft lb) admissible for main travelling direction with gear lever set to «B».

\*\* Max 45 kW for main travelling direction with gear lever set to «B».

MODEL	RATIO		POWER / RPM		INPUT POWER CAPACITY						MAX RPM	WEIGHT		BELL HSGS. AND NOTES
	«A» Pos	«B»Pos	kW	hp	kW	hp	kW	hp	kW	hp		kg	lb	
					3000 rpm	3600 rpm	3800 rpm							
ZF 15 MIV 8 degrees	2.134	2.224	0.0152	0.0204	46	61	55	73	55	74	5000	21	47	SAE 4, 5, B/W, Yanmar JH Max input power 55 kW. <b>Ratio 2.134 «B» Pos. max torque 120 Nm.</b>
	2.718	2.224	0.0111	0.0149	33	45	40	54	42	57	5000			
	2.995	2.224												

**K = 1.25 to be applied, if engine has 1 cylinder - K = 1.20 for 2 cylinders - K = 1.15 for 3 cylinders**

\*\* Max. 230 Nm (170 ft lb) admissible for main travelling direction with gear lever set to «B»

MODEL	RATIO		POWER / RPM		INPUT POWER CAPACITY						MAX RPM	WEIGHT		BELL HSGS. AND NOTES
	«A» Pos	«B»Pos	kW	hp	kW	hp	kW	hp	kW	hp		kg	lb	
					3000 rpm	3600 rpm	3800 rpm							
ZF 25 M	1.880	2.095	0.0262	0.0351	79	105	80	107	80	107	5000	18.5	41	SAE 4, 5, B/W, Yanmar JH Max input power 80 kW. <b>Ratio 1.880 «B» Pos. max torque 230 Nm.</b>
	2.273	2.095	0.0216	0.0289	65	87	78	104	80	107	5000			
	2.737	2.722	0.0177	0.0237	53	71	64	85	67	90	5000			

**K = 1.25 to be applied, if engine has 1 cylinder / K = 1.20 for 2 cylinders / K = 1.15 for 3 cylinders**

\*\* Max. 169 Nm (125 ft lb) admissible for main travelling direction with gear lever set to «B»

MODEL	RATIO		POWER / RPM		INPUT POWER CAPACITY						MAX RPM	WEIGHT		BELL HSGS. AND NOTES
	«A» Pos	«B»Pos	kW	hp	kW	hp	kW	hp	kW	hp		kg	lb	
					3000 rpm	3600 rpm	3800 rpm							
ZF 25 MA 8 degrees	2.227	2.737	0.0215	0.0288	64	86	77	104	80	107	5000	21.1	47	SAE 4, 5, B/W, Yanmar JH Max input power 80 kW. <b>Ratio 2.227 «B» Pos. max torque 169 Nm.</b>
	2.737	2.737	0.0177	0.0237	53	71	64	85	67	90	5000			

**K = 1.25 to be applied, if engine has 1 cylinder / K = 1.20 for 2 cylinders / K = 1.15 for 3 cylinders**

\*\* Max. 185 Nm (137 ft lb) admissible for main travelling direction with gear lever set to «B»

MODEL	RATIO		POWER / RPM		INPUT POWER CAPACITY						MAX RPM	WEIGHT		BELL HSGS. AND NOTES
	«A» Pos	«B»Pos	kW	hp	kW	hp	kW	hp	kW	hp		kg	lb	
					3000 rpm	3600 rpm	3800 rpm							
ZF 30 M	2.148	2.636	0.0241	0.0323	72	97	87	116	92	123	5000	23	51	4 & 5 Yanmar JH Max input power 95 kW. <b>Ratio 2.148 «B» Pos. max torque 185 Nm. Ratio 2.696 «B» Pos. max torque 185 Nm.</b>
	2.696	2.636												

«A» POS = continuous running position (normally AHEAD).

«B» POS = reverse position.

B/W = Borg Warner adaptor.

Note = For all «M» (Mechanical) transmissions reduce power capacity by the following shock factors: 1 cylinder engine ÷ 1.25, 2 cylinder engine ÷ 1.20, 3 cylinder engine ÷ 1.15.

## 9.1 Garantia

### 9.1.1 CONDIÇÕES DA GARANTIA

ZF Marine Arco S.p.A. garante seu Reversor Marítimo tipo ZFM contra qualquer defeito do material e/ou de mão-de-obra sob condições normais de uso e manutenção, sendo que esta garantia somente será aplicável se, e somente se, o equipamento tiver sido instalado e utilizado corretamente.

As obrigações de ZF Marine Arco S.p.A. com esta garantia se limitarão à substituição ou à reparação, a seu critério, de qualquer peça ou peças reconhecida(s) como defeituosas por ZF Marine Arco S.p.A., depois de tê-las examinado, com a condição de que a peça ou as peças sejam entregues ao distribuidor oficial ZF Marine Arco S.p.A. mais próximo, com frete pago antecipadamente, dentro do seguinte período:

Vinte e quatro (24) meses a partir da data de comissionamento ou trinta e seis (36) meses desde a data de entrega ao fabricante de motores, o que ocorrer primeiro.

As obrigações de ZF Marine Arco S.p.A. quanto à presente garantia, tal e como está expressa, estão, além disso, condicionadas ao cumprimento dos Procedimentos de Garantia que integram esta garantia por parte do distribuidor ou fabricante de motores que adquiriu o produto.

Todas as reivindicações de garantia deverão ser encaminhadas ao distri-

buidor ou fabricante de motores que adquiriu o Reversor Marítimo tipo ZFM. Esta garantia não será aplicável a qualquer peça ou peças que tenham sido reparadas ou modificadas sem o consentimento prévio por escrito de um concessionário oficial ZF Marine Arco S.p.A..

Esta garantia não será válida se o produto ou algum de seus componentes ou peças tiverem sido submetidos à utilização incorreta, uso abusivo, negligência, modificações ou acidente, ou se as instruções escritas de ZF Marine Arco S.p.A. não tiverem sido seguidas, ou se o equipamento tiver funcionado em condições mais severas ou que excedam àquelas especificadas adiante para o mencionado produto, ou que tenha sido instalado ou reinstalado incorretamente, ou tenha recebido manutenção inadequada ou ter sido operado de modo incorreto. Esta garantia substitui qualquer outra garantia explícita ou implícita incluindo a garantia de comercialização e de bom uso e outras eventuais obrigações que compreendam danos indiretos derivadas da operação do produto.

ZF Marine Arco S.p.A. não se responsabilizará nem autorizará que outras pessoas assumam em seu nome qualquer outra responsabilidade relacionada à venda do Reversor Marítimo ZFM. ZF Marine Arco S.p.A. em nenhum caso será responsável por danos que superem o preço de compra do Reversor Marítimo ZFM.

### 9.1.2 RESPONSABILIDADE TORSIONAL E ACOPLAMENTO TORSIONAL

A responsabilidade de assegurar a compatibilidade Torsional é do montador do equipamento. A ZF Marine Arco S.p.A. não se responsabiliza por barulho causado por vibração ou danos no reversor, no Acoplamento elástico ou outras partes do sistema, causado por esse tipo de vibração.

Contate a ZF Marine Arco S.p.A. para mais informações e assistência.

ZF Marine Arco S.p.A. recomenda o uso do limite máximo torsional para sistemas com motorização simples, onde a perda de potência pode resultar em perda de controle. É de responsabilidade do comprador especificar a opção, que pode resultar em custo adicional e a possibilidade de aumento no tempo de instalação.

A ZF não se responsabiliza por danos pessoais, morte ou perda de propriedade por falha do comprador em não especificar o limite máximo torsional. A ZF Marine Arco S.p.A. escolhe o acoplamento elástico com base na faixa de torque nominal de entrada e comumente aceita pela velocidade do motor. Consulte a ZF Marine Arco S.p.A. para detalhes referentes a limites básicos de velocidade de acoplamento torsional, que podem ser menor que o limite do reversor. Acoplamento torsional especial pode ser requerido pela sociedade classificadora (SSIC).



## NEDERLANDS

### Hoofdstuk

1.1	Inleiding .....	54
2.1	Gegevens van de omkeerinrichting .....	54
3.1	Beschrijving .....	54
4.1	Installatie .....	54
5.1	Bediening .....	55
6.1	Onderhoud .....	56
7.1	Storingen .....	57
8.1	Technische gegevens .....	58
9.1	Garantie .....	60
10.1	Lijst van aanbevolen vloeistoffen .....	82
11.1	Installatietekeningen .....	83
12.1	Dealerlijst .....	84
13.1	Warranty Card .....	95

## 1.1 Inleiding

### 1.1.1 VERANTWOORDELIJKHEDEN VAN DE KLANT

De klant/gebruiker is verantwoordelijk voor het uitvoeren van de noodzakelijke veiligheidscontroles om te verzekeren dat smering, koeling, onderhoud en aanbevolen procedures strikt worden uitgevoerd om veilig en probleemloos gebruik te waarborgen.

Voor alle keerkoppelingen geldt een beperkte garantie. Daarom: dienen met betrekking tot het omgaan met de keerkoppelingen de instructies uit deze handleiding strikt te worden opgevolgd.



#### LET OP!

De fabrikant is niet aansprakelijk voor eventuele schade of verliezen veroorzaakt door onjuiste installatie, verkeerde bediening van de apparatuur en/of gebrekkig onderhoud. De klant dient te verzekeren dat het optreden van eventuele externe krachten, alsmede van trillingen veroorzaakt door torsie en buiging, wordt voorkomen. De interactie tussen motor, as en schroef kan leiden tot torsietrillingen die een hamerend geluid veroorzaken en de motor en/of de keerkoppeling kunnen beschadigen. De leverancier is niet aansprakelijk voor dergelijke torsietrillingen, die inherent zijn aan de installatie.

Deze handleiding omvat onder andere de volgende drie hoofdstukken:

### 1.1.2 BESCHRIJVING

In dit gedeelte wordt een korte beschrijving gegeven van werking, bediening en ontwerp van de ZFM.

### 1.1.3 BEDIENING

In dit gedeelte worden de bedieningsprocedures en alle benodigde veiligheidsmaatregelen beschreven.

### 1.1.4 ONDERHOUD

In dit gedeelte worden alle onderhouds- en servicewerkzaamheden beschreven die moeten worden uitgevoerd door de gebruiker. Wanneer in deze handleiding de termen "rechts, links, stuurboord, bakboord" worden gebruikt, hebben deze altijd betrekking op de geïnstalleerde keerkoppeling in voorwaartse bewegingsrichting. Op belangrijke informatie m.b.t. technische betrouwbaarheid en bedrijfsveiligheid wordt de aandacht gevestigd door de volgende woorden:



#### WAARSCHUWING

**Als deze procedure, voorwaarde, aanwijzing etc. niet strikt in acht wordt genomen, kan dit resulteren in persoonlijk letsel of overlijden.**



#### LET OP!

**Als deze procedure, voorwaarde, aanwijzing etc. niet strikt in acht wordt genomen, kan dit resulteren in beschadiging of vernieling van apparatuur.**

**OPMERKING:** Heeft betrekking op technische eisen waaraan de gebruiker van de apparatuur speciale aandacht moet schenken.

De woorden **WAARSCHUWING**, **LET OP!** en **OPMERKING** staan altijd voor de tekst waarop zij betrekking hebben.

## 2.1 Gegevens van de omkeerinrichting

Het identificatieplaatje is op de omkeerinrichting aangebracht. In Fig. 1 is een voorbeeld van een identificatieplaatje afgebeeld:

- A** Serienummer van de omkeerinrichting.
  - B** Code van de overbrenging.
  - C** Overbrengingsverhouding voor schoep die in dezelfde richting als de motor draait.
  - D** Overbrengingsverhouding voor schoep die in tegengestelde richting van de motor draait.
  - E** Ieder jaar wordt er een andere opeenvolgende letter toegekend.
  - F** ype omkeerinrichting.
- Betekenis van de aanduidingen van de omkeerinrichtingen:
- G** ype omkeerinrichting.
  - H** Grootte van de omkeerinrichting
  - I** Versie van de omkeerinrichting

## 3.1 Beschrijving

ZF M-keerkoppelingen zijn automatisch geregelde schroefwieloverbrengingen.

Ze zijn stevig van constructie en uiterst betrouwbaar. Desondanks is het essentieel dat de gebruiker de volgende instructies m.b.t. installatie, bediening en onderhoud in acht neemt. Wanneer dit wordt nagelaten of wanneer ongeoorloofde aanpassingen aan de keerkoppeling plaatsvinden, komt hierdoor elke aanspraak op garantie te vervallen. Bij de fabrikant is een onderhoudshandleiding verkrijgbaar.

Fig. 2:

- 1) Warmtewisselaar
- 2) Uitgangsf lens
- 3) Identificatieplaat
- 4) Activeringshendel
- 5) Beugel afstandsbediening
- 6) Schijf
- 7) Ingangsas
- 8) Oliepeilstok

## 4.1 Installatie

Bij montage van de ZFM keerkoppeling dient speciale aandacht te worden geschonken aan de volgende punten:

- Installeer een geschikte dempende koppeling tussen de motor en de keerkoppeling.
- **SCHUINE STAND:** (Fig. 3): De positie van de transmissie mag, ten opzichte van de ingangsas, niet meer dan 20° zijn (15° voor ZF MIV), in continu bedrijf. De toegestane zijwaartse schuinstand kan bij de fabrikant worden opgevraagd.

• **KOPPELINGEN:** Torsie-elastische koppeling met min 0.5 mm radiale speling vereist aan motorzijde; flexibele elastische koppeling aanbevolen aan schroefzijde.

• **VERBINDING MOTOR-KEERKOPPELING** (Fig. 4):

- 1) Motorflens
- 2) Vliegwiel.
- 3) Elastische koppeling.
- 4) As van de keerkoppeling.
- 5) Flens keerkoppeling.
- 6) Flens vliegwiel.

Maximaal toegestane radiale en axiale waarden X: B-0,1 mm.

• **VERBINDING KEERKOPPELING-SCHROEFAS** (Fig. 5 - 6):

• Kies een geschikte koeler.

Voor gedetailleerde informatie wordt verwezen naar de installatiehandleiding.

**Vloeistoftype:** ATF (automatische transmissievloeistof); zie hoofdstuk 10.1.

## 5.1 Bediening

Alle keerkoppelingen hebben vóór verzending proefgedraaid.

Tijdens normaal bedrijf mag de keerkoppeling alleen worden bediend wanneer de motor stationair draait.

In noodgevallen is het tevens toegestaan bij hogere toerentallen te schakelen.

De goede werking van het hydraulische circuit wordt alleen gegarandeerd als de hydraulische vloeistof regelmatig vervangen wordt, zoals voorgeschreven in het onderhoudsprogramma. (Zie hoofdstuk 6.1).

Van tijd tot tijd dienen visuele controles op lekkage te worden uitgevoerd.



### WAARSCHUWING

Werkzaamheden aan de keerkoppeling mogen alleen worden uitgevoerd als motor en schroef stilstaan.



### LET OP!

Voordat voor het eerst wordt gestart moet de keerkoppeling met transmissievloeistof worden gevuld.

Voor vulprocedure, vloeistoftype, -hoeveelheid en -peil wordt verwezen naar hoofdstuk 6.1.4 en vloeistof verversen.



### LET OP!

Wanneer de keerkoppeling met een te laag oliepeil wordt gebruikt, zal dit de tandwielen beschadigen.

Een te hoog oliepeil kan lekkage bij de asafdichtingen en de ontluchter van de keerkoppeling veroorzaken en de bedrijfstemperatuur aanzienlijk verhogen.

### 5.1.1 BEDIENINGS-PROCEDURE



### LET OP!

Voordat de keerkoppeling wordt gebruikt, moet het vloeistofpeil worden gecontroleerd (zie hoofdstuk 6.1.1).



### LET OP!

Tijdens normaal bedrijf mag de keerkoppeling alleen worden bediend wanneer de motor stationair draait. Schakelen bij een hoger motortoerental kan leiden tot overbelasting van de koppelingsplaten en dient tijdens normaal bedrijf te worden voorkomen.

**Opmerking:** In geval van nood kan de keerkoppeling van vooruit naar achteruit worden geschakeld, ook bij een hoog motortoerental.

### SCHAKELSTANDEN (FIGUUR 7):

A = Draairichting schroef tegengesteld aan draairichting motor

N = Neutrale stand

B = Draairichting schroef gelijk aan draairichting motor



### WAARSCHUWING

Start de motor met de keerkoppeling alleen in de neutrale stand.

De normale bedrijfstemperatuur van de transmissieolie dient te liggen in het bereik van 50°C tot 80°C.

De max. toegestane ATF-temperatuur van 100°C mag alleen gedurende korte tijd worden bereikt.



### LET OP!

Als de vloeistoftemperatuur te hoog is onmiddellijk de motor stilzetten,

het peil van de transmissievloeistof inspecteren en controleren of het water door de oliekoeler goed stroomt. De motor mag pas weer worden gestart als de storing is verholpen.

### 5.1.2 ZEILEN, SLEEP OF VOOR ANKER

Als de motor uit is en de boot met het zeil vaart, zowel als hij aangesleept wordt of voor anker ligt, kan de schroef draaien door het effect van de stroming. Dit is niet gevaarlijk voor de keerkoppeling. Bij een boot met twee motoren kan de schroef van de niet-ingeschakelde keerkoppeling probleemloos stationair draaien. Wanneer de motor is uitgeschakeld, maakt het niet uit in welke stand de schakelhendel staat.



### LET OP!

Stationaire stand van de schroef: de versnellingshendel moet in de 'N' (Fig.7)-stand staan. Gebruik de schakelstand tegenovergesteld aan de bewegingsrichting om de schroefas vast te zetten, anders wordt de keerkoppeling beschadigd.



### WAARSCHUWING

Werk niet aan een keerkoppeling wanneer u wordt gesleept of voor anker gaat in een rivier. De schroef kan dan namelijk gaan draaien.



### WAARSCHUWING

Werk niet aan een keerkoppeling in een varende tweemotorige boot wanneer één van de motoren draait. De schroefas van de niet-werkende transmissie zal vrij kunnen draaien.



### WAARSCHUWING

Wanneer de motor stationair draait, maar de schroefas niet moet worden aangedreven (bijv. wanneer de accu met de dynamo wordt opgeladen), moet de schakelhendel (figuur 7) in de neutrale stand (N) worden gehouden om te voorkomen dat de boot beweegt. Laat de hydraulische keerkoppeling niet langdurig met hoog toerental in de vrijloop (N) draaien.

### 5.1.3 BEDIENINGSSYSTEEM



**LET OP!**

Controleer of de bedieningsstang of kabel soepel beweegt.

#### SCHAKELWEG:

Mod: ZF 5 M - 6 M - 10 M - 12 M - 15 M  
- 15 MA - 15 MIV - 25 M - 25 MA  
- 30 M.

De minimale schakelweg (N-A=N-B) moet 35 mm zijn voor het buitenste scharnierpunt en 30 mm voor het binnenste scharnierpunt.

#### Fig. 8:

- 1) Bevestigingsschroef hendel aanhaalmoment  $22 \pm 1$  Nm.
- 2) Minimale schakelweg voor de bedieningskabel
- 3) Demonteer het bedieningsdeksel niet.
- 4) Olieaftapdop.  
Aanhaalmoment:  $Ma = 22$  Nm (16 lb-ft).

#### SCHAKELWEG:

Mod: ZF 4-1 M

De schakelweg (N-A=N-B) moet  $38,5 \pm 1,5$  mm zijn voor het buitenste scharnierpunt en  $33,5 \pm 1,5$  mm voor het binnenste scharnierpunt (vanuit neutrale stand).

Wanneer de hendel een hoek van meer dan  $10^\circ$ - $12^\circ$  maakt, begint deze loodrecht naar buiten te bewegen en stopt deze wanneer de weg is afgelegd (hoek van  $40^\circ$ ).

#### Fig. 9:

- 1) Bevestigingsschroef hendel aanhaalmoment  $22 \pm 1$  Nm.
- 2) Demonteer afdichtingsring
- 3) Demonteer het bedieningsdeksel niet.

#### HENDELSTAND:

In neutrale stand loodrecht op bedieningsstang of -kabel. De schakelhendel kan met behulp van een klemschroef in elke stand worden vastgezet. Minimumafstand tussen schakelhendel en -deksel is 0.5 mm. Wanneer het deksel wordt geopend of losgemaakt, moet opnieuw worden afgesteld (mag alleen worden uitgevoerd door gespecialiseerd personeel).

#### Fig. 10:

- 1) Oliepeilstok en olievuldop (17 mm)  
Aanhaalmoment:  $Ma = 20$  Nm (15 lb-ft).
- 2) Afstand bedieningshendel van het deksel min 0,5 mm.

**CONTROLES:** Om een goede werking te kunnen garanderen moet de positie van de hendel regelmatig gecontroleerd worden.

## 6.1 Onderhoud

### 6.1.1 VLOEISTOFPEIL-CONTROLE



**WAARSCHUWING**

**Werk niet aan de keerkoppeling wanneer u wordt gesleept of voor anker gaat in een rivier. De schroef kan dan namelijk gaan draaien.**

### BESCHRIJVING OLIESTOK (Fig.11):

- 1) Oppervlakte behuizing.
- 2) Oliepeilstok.
- 3) Oliepeil.
- 4) ATF olie.
- 5) Afdichtingsring.

Het transmissievloeistofpeil kan in koude of warme toestand worden gecontroleerd.

**N.B.:** Controleer altijd het oliepeil alvorens de omkeerinrichting in bedrijf te stellen door als volgt te werk te gaan.

- Draai de vloeistofpeilstok (figuur 11) los door de greep linksom te draaien.
- Veeg de peilstok met een schone en stofvrije doek af.
- Steek de peilstok naar binnen – niet erin schroeven. Verwijder peilstok en controleer vloeistofpeil: Het vloeistofpeil moet zich tussen het minimum- en het maximummerkteken bevinden (3-4figuur 11).
- Steek de peilstok naar binnen en draai deze vast door de greep rechtsom te draaien.



**LET OP!**

**Afhankelijk van het type en de plaatsing van de koeler en de leidingen**

zal zich een bepaalde hoeveelheid olie verzamelen nadat de motor is stilgezet en zal deze na een langere stilstandperiode in de keerkoppeling terugstromen.

Hierdoor kan het oliepeil in de keerkoppeling boven het max. merkteken komen. Verwijder de overtollige olie niet, maar ga volgens te werk.

- Laat de motor stationair draaien (met de schakelhendel in de neutrale stand) totdat de oliekoeler en alle leidingen met vloeistof zijn gevuld.
- Schakel de motor uit en controleer direct daarna het vloeistofpeil. Indien noodzakelijk, olie bijvullen tot het merkteken op de peilstok.  
Het met de peilstok gemeten vloeistofpeil (figuur 11) moet tussen het min. en het max. merkteken liggen. Het vloeistofpeil moet na een korte gebruiksperiode opnieuw worden gecontroleerd.

### 6.1.2 VLOEISTOFVERVERSEN



**LET OP!**

**De eerste verversing moet worden uitgevoerd na 25 bedrijfsuren. Hierna dient de olie na elke 300 bedrijfsuren of eenmaal per jaar te worden ververs (afhankelijk van de termijn die het eerst is verstreken).**



**LET OP!**

**De oude olie moet als speciaal afval beschouwd worden waardoor het milieu verontreinigd wordt: de olie moet dus afgevoerd worden in functie van zijn gedifferentieerde structuur.**

### 6.1.3 TRANSMISSIEVLOEISTOF AFTAPPEN

Verwijder de dop (1 Fig. 12) en laat de olie weglopen door de speciale opening in de onderkant van de behuizing.

### 6.1.4 VULLEN MET TRANSMISSIEVLOEISTOF

Vullen met olie voor automatische versnellingen ATF volgens de als volgt weergegeven hoeveelheden.

Vul de hoeveelheid toe die nodig geacht wordt voor het vullen van de warmtewisselaar en de desbetreffende verbindingsslangen.

ZF 4-1 M: .....	0,42 liter
ZF 5 M: .....	0,42 liter
ZF 6 M: .....	0,42 liter
ZF 10 M: .....	0,42 liter
ZF 12 M: .....	0,60 liter
ZF 15 M: .....	0,60 liter
ZF 15 MA: .....	0,56 liter
ZF 15 MIV: .....	1,00 liter
ZF 25 M: .....	0,75 liter
ZF 25 MA: .....	0,75 liter
ZF 30 M: . min. 0,90 - max. 1,10 liter	

• Geldig voor inclinatie van de onderste as op 20 graden (15° voor ZF MIV).

Gebruik alleen olie voor automatische versnellingen volgens de specificaties vermeld in de «Lijst met aanbevolen oliesoorten» op pag.82.

### 6.1.5 PROEFDRAAIEN

- 1) Laat de keerkoppeling na het verversen van de olie proefdraaien.
- 2) Zet de schakelhendel in de neutrale stand (N).  
Start de motor en laat deze kort stationair draaien om de koeler en de leidingen met transmissieolie te vullen.
- 3) Stop de motor en controleer het oliepeil opnieuw. Vul zonnodig olie bij. Overtollige olie moet worden verwijderd. Het met de peilstok ge-

meten oliepeil moet tussen het min. en het max. merkteken liggen. Het oliepeil moet na een korte gebruikperiode opnieuw worden gecontroleerd.

### 6.1.6 OPSLAG

Als de keerkoppeling gedurende langere tijd wordt opgeslagen (bijv. in de winter), dient deze via het peilstokgat volledig te worden gevuld met ATF om corrosie te voorkomen.



#### LET OP!

**Ververs de olie wanneer de keerkoppeling weer in gebruik wordt genomen, overeenkomstig eerder vermelde instructie.**

## 7.1 Storingen

Controleer allereerst of de instructies van de vorige punten opgevolgd zijn.

AFWIJKING	MOGELIJKE OORZAAK	OPLOSSING
<b>1. Hoge olietemperatuur</b>	<ul style="list-style-type: none"> <li>- Te hoog olieniveau</li> <li>- Te laag olieniveau</li> <li>- Warmtewisselaar verstopt</li> <li>- Geen water in het circuit</li> </ul>	<ul style="list-style-type: none"> <li>- overtollige olie verwijderen</li> <li>- bijvullen</li> <li>- warmtewisselaar vervangen en watercircuit nakijken</li> <li>- circuit nakijken en lek repareren.</li> </ul>
<b>2. Aanwezigheid van olie op de behuizing</b>	<ul style="list-style-type: none"> <li>- Schroeven los</li> <li>- Verbindingen los</li> <li>- Oliepeilstok los</li> <li>- Te hoog olieniveau tijdens de werking</li> </ul>	<ul style="list-style-type: none"> <li>- aandraaien op het juiste aanhaalmoment</li> <li>- aandraaien of vervangen</li> <li>- aandraaien of vervangen</li> <li>- aanzuigen tot aan het max. teken</li> </ul>
<b>3. Moeilijke inschakeling</b>	<ul style="list-style-type: none"> <li>- Blokkering verdeler</li> <li>- Afstandsbediening</li> </ul>	<ul style="list-style-type: none"> <li>- een servicecentrum raadplegen</li> <li>- regeling</li> </ul>
<b>4. Langzame inschakeling</b>	<ul style="list-style-type: none"> <li>- Blokkering verdeler</li> <li>- Afstandsbediening</li> </ul>	<ul style="list-style-type: none"> <li>- een servicecentrum raadplegen</li> <li>- regeling</li> </ul>
<b>5. De boot beweegt niet</b>	<ul style="list-style-type: none"> <li>- Blokkering verdeler</li> <li>- Verkeerde positie van de bedieningshendel</li> <li>- Laag olieniveau</li> <li>- Schroef verloren</li> <li>- Schroefas kapot</li> <li>- Transmissie werkt niet goed</li> <li>- Motor werkt niet goed</li> </ul>	<ul style="list-style-type: none"> <li>- een servicecentrum raadplegen</li> <li>- regeling</li> <li>- bijvullen</li> <li>- opnieuw installeren</li> <li>- een servicecentrum raadplegen</li> <li>- een servicecentrum raadplegen</li> <li>- een servicecentrum raadplegen</li> </ul>





## 8.1 Technische gegevens

### Technical Data for Pleasure Craft Duty

Based on engine power B to DIN 6270; shock factor

**K = 1.25 to be applied, if engine has 1 cylinder / K = 1.20 for 2 cylinders / K = 1.15 for 3 cylinders**

MODEL	RATIO		POWER / RPM		INPUT POWER CAPACITY						MAX RPM	WEIGHT		BELL HSGS. AND NOTES
	«A» Pos	«B»Pos	kW	hp	2800 rpm		3000 rpm		3600 rpm			kg	lb	
					kW	hp	kW	hp	kW	hp				
ZF 5 M	2.045	1.864	0.0066	0.0088	18	25	20	27	20	27	5000	8.5	19	SAE 6, B/W Max input power 20 kW
	2.722	2.150	0.0047	0.0063	13	18	14	19	17	23				

**K = 1.25 to be applied, if engine has 1 cylinder / K = 1.20 for 2 cylinders / K = 1.15 for 3 cylinders**

MODEL	RATIO		POWER / RPM		INPUT POWER CAPACITY						MAX RPM	WEIGHT		BELL HSGS. AND NOTES
	«A» Pos	«B»Pos	kW	hp	2800 rpm		3000 rpm		3600 rpm			kg	lb	
					kW	hp	kW	hp	kW	hp				
ZF 6 M	2.045	1.864	0.0066	0.0088	18	25	20	27	20	27	5000	10.3	23	SAE 4, 5, 6, B/W Max input power 20 kW
	2.722	2.150	0.0047	0.0063	13	18	14	19	17	23				

**K = 1.25 to be applied, if engine has 1 cylinder / K = 1.20 for 2 cylinders / K = 1.15 for 3 cylinders**

\*\* Max. 95 Nm (70 ft lb) admissible for main travelling direction with gear lever set to «B»

MODEL	RATIO		POWER / RPM		INPUT POWER CAPACITY						MAX RPM	WEIGHT		BELL HSGS. AND NOTES
	«A» Pos	«B»Pos	kW	hp	2800 rpm		3000 rpm		3600 rpm			kg	lb	
					kW	hp	kW	hp	kW	hp				
ZF 10 M	1.482	1.864	0.0109	0.0146	30	41	33	44	38	51	5000	10.3	23	SAE 4, 5, 6, B/W Max input power 38 kW. <b>Ratio 1.482 «B» Pos. max torque 95 Nm. Ratio 1.792 «B» Pos. max torque 95 Nm.</b>
	1.792	1.864												
	2.045	1.864	0.0095	0.0128	27	36	29	38	34	46				
	2.722	2.150	0.0068	0.0091	19	26	20	27	25	33				

**K = 1.25 to be applied, if engine has 1 cylinder / K = 1.20 for 2 cylinders / K = 1.15 for 3 cylinders**

MODEL	RATIO		POWER / RPM		INPUT POWER CAPACITY						MAX RPM	WEIGHT		BELL HSGS. AND NOTES
	«A» Pos	«B»Pos	kW	hp	2800 rpm		3000 rpm		3600 rpm			kg	lb	
					kW	hp	kW	hp	kW	hp				
ZF 12 M	2.136	1.955	0.0131	0.0176	37	49	39	53	47	63	5000	13	29	SAE 4, 5, 6, B/W, Yanmar JH Max input power 55 kW
	2.632	1.955	0.0111	0.0149	31	42	33	45	40	54				

**K = 1.25 to be applied, if engine has 1 cylinder / K = 1.20 for 2 cylinders / K = 1.15 for 3 cylinders**

\*\* Max. 120 Nm (88.5 ft lb) admissible for main travelling direction with gear lever set to «B»

MODEL	RATIO		POWER / RPM		INPUT POWER CAPACITY						MAX RPM	WEIGHT		BELL HSGS. AND NOTES
	«A» Pos	«B»Pos	kW	hp	3000 rpm		3600 rpm		3800 rpm			kg	lb	
					kW	hp	kW	hp	kW	hp				
ZF 15 M	1.556	1.955	0.0152	0.0204	46	61	55	73	55	74	5000	13	29	SAE 4, 5, 6, B/W, Yanmar JH Max input power 55 kW. <b>Ratio 1.556 «B» Pos. max torque 120 Nm. Ratio 1.875 «B» Pos. max torque 120 Nm.</b>
	1.875	1.955												

«A» POS = continuous running position (normally AHEAD).

«B» POS = reverse position.

B/W = Borg Warner adaptor.

Note = For all «M» (Mechanical) transmissions reduce power capacity by the following shock factors: 1 cylinder engine ÷ 1.25, 2 cylinder engine ÷ 1.20, 3 cylinder engine ÷ 1.15.





**K = 1.25 to be applied, if engine has 1 cylinder / K = 1.20 for 2 cylinders / K = 1.15 for 3 cylinders**

\*\* Max. 120 Nm (88.5 ft lb) admissible for main travelling direction with gear lever set to «B»

MODEL	RATIO		POWER / RPM		INPUT POWER CAPACITY						MAX RPM	WEIGHT		BELL HSGS. AND NOTES	
	«A» Pos	«B»Pos	kW	hp	3000 rpm		3600 rpm		3800 rpm			kg	lb		
					kW	hp	kW	hp	kW	hp					
ZF 15 MA 8 degrees	1.875	1.955	0.0152	0.0204	46	61	55	73	55	74	5000	13.5	30	SAE 4, 5, 6, B/W, Yanmar JH Max input power 55 kW. <b>Ratio 1.875 «B» Pos. max torque 120 Nm. Ratio 2.136 «B» Pos. max torque 120 Nm.</b>	
	2.136	1.955	0.0131	0.0176	39	53	47	63	50	67					5000
	2.632	1.955	0.0111	0.0149	33	45	40	54	42	57					5000

**K = 1.25 to be applied, if engine has 1 cylinder / K = 1.20 for 2 cylinders / K = 1.15 for 3 cylinders**

\* Max. 120 Nm (88.5 ft lb) admissible for main travelling direction with gear lever set to «B».

\*\* Max 45 kW for main travelling direction with gear lever set to «B».

MODEL	RATIO		POWER / RPM		INPUT POWER CAPACITY						MAX RPM	WEIGHT		BELL HSGS. AND NOTES	
	«A» Pos	«B»Pos	kW	hp	3000 rpm		3600 rpm		3800 rpm			kg	lb		
					kW	hp	kW	hp	kW	hp					
ZF 15 MIV 8 degrees	2.134	2.224	0.0152	0.0204	46	61	55	73	55	74	5000	21	47	SAE 4, 5, B/W, Yanmar JH Max input power 55 kW. <b>Ratio 2.134 «B» Pos. max torque 120 Nm.</b>	
	2.718	2.224	0.0111	0.0149	33	45	40	54	42	57					5000
	2.995	2.224													

**K = 1.25 to be applied, if engine has 1 cylinder - K = 1.20 for 2 cylinders - K = 1.15 for 3 cylinders**

\*\* Max. 230 Nm (170 ft lb) admissible for main travelling direction with gear lever set to «B»

MODEL	RATIO		POWER / RPM		INPUT POWER CAPACITY						MAX RPM	WEIGHT		BELL HSGS. AND NOTES	
	«A» Pos	«B»Pos	kW	hp	3000 rpm		3600 rpm		3800 rpm			kg	lb		
					kW	hp	kW	hp	kW	hp					
ZF 25 M	1.880	2.095	0.0262	0.0351	79	105	80	107	80	107	5000	18.5	41	SAE 4, 5, B/W, Yanmar JH Max input power 80 kW. <b>Ratio 1.880 «B» Pos. max torque 230 Nm.</b>	
	2.273	2.095	0.0216	0.0289	65	87	78	104	80	107					5000
	2.737	2.722	0.0177	0.0237	53	71	64	85	67	90					5000

**K = 1.25 to be applied, if engine has 1 cylinder / K = 1.20 for 2 cylinders / K = 1.15 for 3 cylinders**

\*\* Max. 169 Nm (125 ft lb) admissible for main travelling direction with gear lever set to «B»

MODEL	RATIO		POWER / RPM		INPUT POWER CAPACITY						MAX RPM	WEIGHT		BELL HSGS. AND NOTES
	«A» Pos	«B»Pos	kW	hp	3000 rpm		3600 rpm		3800 rpm			kg	lb	
					kW	hp	kW	hp	kW	hp				
ZF 25 MA 8 degrees	2.227	2.737	0.0215	0.0288	64	86	77	104	80	107	5000	21.1	47	SAE 4, 5, B/W, Yanmar JH Max input power 80 kW. <b>Ratio 2.227 «B» Pos. max torque 169 Nm.</b>
	2.737	2.737	0.0177	0.0237	53	71	64	85	67	90				

**K = 1.25 to be applied, if engine has 1 cylinder / K = 1.20 for 2 cylinders / K = 1.15 for 3 cylinders**

\*\* Max. 185 Nm (137 ft lb) admissible for main travelling direction with gear lever set to «B»

MODEL	RATIO		POWER / RPM		INPUT POWER CAPACITY						MAX RPM	WEIGHT		BELL HSGS. AND NOTES
	«A» Pos	«B»Pos	kW	hp	3000 rpm		3600 rpm		3800 rpm			kg	lb	
					kW	hp	kW	hp	kW	hp				
ZF 30 M	2.148	2.636	0.0241	0.0323	72	97	87	116	92	123	5000	23	51	4 & 5 Yanmar JH Max input power 95 kW. <b>Ratio 2.148 «B» Pos. max torque 185 Nm. Ratio 2.696 «B» Pos. max torque 185 Nm.</b>
	2.696	2.636												

«A» POS = continuous running position (normally AHEAD).

«B» POS = reverse position.

B/W = Borg Warner adaptor.

Note = For all «M» (Mechanical) transmissions reduce power capacity by the following shock factors: 1 cylinder engine ÷ 1.25, 2 cylinder engine ÷ 1.20, 3 cylinder engine ÷ 1.15.

## 9.1 Garantie

### 9.1.1 STANDAARDGARANTIE

ZF Marine Arco S.p.A. garandeert dat haar ZFM-keerkoppeling vrij is van materiaaldefecten en constructiefouten bij normaal gebruik en onderhoud, met dien verstande dat deze garantie alleen geldt als de apparatuur op de juiste wijze is geïnstalleerd en gebruikt.

De verplichting van ZF Marine Arco S.p.A. is bij deze garantie beperkt tot vervanging of reparatie, naar eigen keuze, van onderdelen die bij onderzoek door ZF Marine Arco S.p.A. defect zijn gebleken, mits deze onderdelen aan de dichtstbijzijnde officiële ZF Marine Arco S.p.A.-dealer franco worden geretourneerd, en wel binnen de volgende periode:

twaalf (12) maanden vanaf de datum van inbedrijfstelling of achttien (18) maanden vanaf de datum van aflevering bij de motorfabrikant (de eerst verlopen termijn geldt).

De hier beschreven garantieverplichtingen van ZF Marine Arco S.p.A. gelden onder voorbehoud dat de dealer of motorfabrikant die het product heeft geleverd, de garantieprocedures heeft uitgevoerd die deel uitmaken van deze garantie.

Garantieclaims dienen te worden ingediend bij de dealer of motorfabrikant die de ZF-keerkoppeling heeft geleverd.

Deze garantie geldt niet voor onderdelen die zonder voorafgaande schriftelijke toestemming van een officiële ZF Marine Arco S.p.A.-dealer zijn gerepareerd of aangepast.

Deze garantie geldt niet als het product of componenten of onderdelen daarvan verkeerd zijn gebruikt, verwaarloosd, aangepast of bij een ongeval zijn betrokken, of niet zijn gebruikt overeenkomstig de gedrukte instructies van ZF Marine Arco S.p.A. of zijn gebruikt onder omstandigheden die zwaarder waren dan, of op andere wijze te boven gingen aan, de omstandigheden omschreven in de specificaties voor het genoemde product, of onjuist (opnieuw) zijn geïnstalleerd of onjuist zijn onderhouden en gebruikt.

Deze garantie geldt uitdrukkelijk in plaats van alle andere expliciete of impliciete garanties inclusief de garanties van verkoopbaarheid en deugdelijkheid en van alle andere verplichtingen, inclusief (maar niet beperkt tot), gevolgschade en ZF Marine Arco S.p.A. aanvaardt geen enkele andere aansprakelijkheid in verband met de verkoop van de keerkoppeling en geeft geen enkele andere persoon toestemming deze aansprakelijkheid voor ZF Marine Arco S.p.A. op zich te nemen.

ZF Marine Arco S.p.A. is in geen enkel geval aansprakelijk voor een schending van de garantiebepalingen voor een bedrag dat de aankoopprijs van de ZFM-keerkoppeling te boven gaat.

### 9.1.2 TORSIE VERANTWOORDELIJKHEID EN TORSIE KOPPELINGEN

De verantwoordelijkheid om «torsional» herenigbaarheid te realiseren rust op de verzamelaar van de aandrijfeenheid en de aangedreven apparatuur.

ZF Marine Arco S.p.A. kan geen aansprakelijkheid accepteren voor geluidsoverlast veroorzaakt door trillingen van de reductie kast, de flexibele koppeling of andere onderdelen van de aandrijfunit.

Voor verdere hulp en informatie kan contact worden opgenomen met ZF Marine Arco S.p.A.

ZF Marine Arco S.p.A. raad het gebruik van een torsie limiet stop aan voor boten die door één motor worden aangedreven, hierbij kan namelijk een verlies aan voortstuwingsvermogen tot controle verlies leiden.

Het is de verantwoordelijkheid van de koper om deze optie te verduidelijken, wat kan resulteren in toenemende kosten en een mogelijk toename van de inbouwtijd. ZF kan geen aansprakelijkheid accepteren voor persoonlijke verwondingen, levensverlies, of beschadigingen/verlies van eigendom veroorzaakt door het nalaten van de koper om een torsie limiet stop te specificeren.

ZF Marine Arco S.p.A. selecteert torsie koppelingen op basis van nominale input van koppel waarden en algemeen geaccepteerde motor snelheden.

Raadpleeg ZF Marine Arco S.p.A. betreffende gegevens over snelheidslimieten van standaard aangeboden torsie koppelingen, deze kan namelijk minder zijn dan het transmissie limiet.

Speciale torsie koppelingen kunnen mogelijk noodzakelijk zijn voor onderzoeksmaatschappij ijs kwalificatie eisen.

## SUOMI

### Sisällysluettelo

1.1	Johdanto.....	61
2.1	Vaihteiston tyyppi .....	61
3.1	Yleisiä tietoja .....	61
4.1	Asennus .....	61
5.1	Käyttö .....	62
6.1	Huolto .....	63
7.1	Vianetsintä.....	64
8.1	Tekniset tiedot .....	65
9.1	Takuu.....	67
10.1	Lista suositelluista öljyistä .....	82
11.1	Edustajaluettelo.....	83
12.1	Asennuspiirustukset .....	84
13.1	Warranty Card .....	95

## 1.1 JOHDANTO

### 1.1.1 ASIAKKAAN VASTUU

Asiakas / käyttäjä on vastuussa välttämättömistä tarkastuksista sen varmistamiseksi, että voitelu, jäähdytys, huolto ja kaikki käyttö- ja huolto ohjeiden mukaiset toimenpiteet tulevat suoritetuksi laitteen turvallisen ja varman käytön takaamiseksi.

Jokaisella ZF:n vaihteistolla on takuu, jonka voimassaolo edellyttää, että näitä käyttöohjeita noudatetaan huolellisesti.



#### VAROITUS

Valmistaja ei ole vastuussa vahingoista jotka johtuvat asennusvirheestä, laitteen väärästä käytöstä ja/tai sen huollon puutteesta.

Asiakkaan tulee varmistaa, että vaihteistoon ei kohdistu ulkoisia voimia kuten vääntöä tai taivutusta jotka voivat aiheuttaa värähtelyä.

Moottorin, akselin ja potkurin välinen vuorovaikutus voi saada aikaan vääntövärähtelyä joka puolestaan aiheuttaa hammaspyörien hakkaavaa ääntä ja saattaa vahingoittaa moottoria ja/tai vaihteistoa.

Valmistaja ei ole vastuussa tällaisesta asennuksesta johtuvasta vääntövärähtelystä.

Tämä ohjekirja sisältää muiden lukujen lisäksi kolme seuraavaa päälukua:

### 1.1.2 YLEISIÄ TIETOJA

Tämä luku kuvaa lyhyesti ZF M vaihteistotyyppien toimintaa, käyttöä ja rakennetta

### 1.1.3 KÄYTTÖ

Tämä luku sisältää käyttöohjeet ja kaikki välttämättömät turvallisuusohjeet.

### 1.1.4 HUOLTO

Tämä luku sisältää kaikki huoltotoimenpiteet jotka käyttäjän on suoritettava.

Tämän ohjekirjan termeillä "vasen, oikea, tyyrpuuri, paapuuri" viitataan aina eteenpäinmenosuuntaan katsottuna vaihteistoon nähden.

Tekniseen luotettavuuteen ja käyttöturvallisuuteen liittyvää tietoa on korostettu käyttäen seuraavia ilmauksia:



#### VAROITUS

**Mikä tahansa menettely, toiminta, tila, huomautus jne, jonka huomioimatta jättäminen voi johtaa loukkaantumiseen tai kuolemantapaukseen.**



#### HUOMIO

**Mikä tahansa menettely, toiminta, tila, huomautus jne, jonka huomioimatta jättäminen voi johtaa laitteen vaurioitumiseen tai tuhoutumiseen.**

**HUOMAUTUS:** Viittaa tekniseen seikkaan joka käyttäjän tulee erityisesti huomioida

Sanat **VAROITUS**, **HUOMIO** ja **HUOMAUTUS** on sijoitettu aina tekstin alkuun välttämättömät turvallisuusohjeet.

## 2.1 Vaihteiston tyyppi

Tunnistuskilpi on kiinnitetty suunnanvaihtimeen. Kuvassa 1 on esimerkki tunnistuskilvestä:

- A** Vaihteiston sarjanumero.
- B** Vaihteiston varaosanumero
- C** Väliytysuhde, kun potkurin pyöri-

missuunta on sama kuin moottorin.

**D** Väliytysuhde, kun potkurin pyörimissuunta on vastakkainen moottorin pyörimissuuntaan verrattuna.

**E** Vuosittain vaihtuva kirjain.

**F** Vaihteiston tyyppi

Vaihteiston nimen selitys:

**G** Vaihteiston tyyppi

**H** Vaihteiston koko

**I** Vaihteiston versio

## 3.1 Yleisiä tietoja

ZF M - merivaihteistot ovat mekaanisesti ohjattuja vinohammasvaihteistoja. Ne ovat vahvarakenteisia ja luotettavia. Asennus on suoritettava ohjeiden mukaisesti ja käytössä on noudatettava käyttö- ja huolto-ohjeita. Ohjeiden noudattamatta jättäminen tai luvattomien muutosten tekeminen vaihteistoon aiheuttavat takuun raukeamisen. Huoltokäsikirja on saatavilla valmistajalta

Kuva 2:

- 1) Jäähdyttävä
- 2) Ulostulolaippa
- 3) Tunnistuskilpi
- 4) Vaihteensiirtovipu.
- 5) Kaukohallintalaitteen teline
- 6) Kytkinlevy
- 7) Sisäänmenoakseli
- 8) Öljyn mittatikku

## 4.1 Asennus

Asennettaessa ZFM vaihteistoa seuraavat seikat tulisi ottaa huomioon:

- Asennus pitäisi suorittaa vain ammattihenkilöiden toimesta.
- **KALLISTUS** (kuva 3):  
Vaihteiston ei tule olla yli 20° (15° ZF MIV) kulmassa sisäänmenoakseliin nähden jatkuvassa käytössä. Suurin mahdollinen sivukallistuskulma kysyttävissä valmistajalta.
- **ELASTISET KYTKIMET:** Moottorin ja vaihteiston väliin asennettava joustava vetolevy jossa vähintään 0,5 mm:n säteisvälys. Potkurin puolelle suositellaan myös joustavaa kytkintä.

## • MOOTTORIN JA VAIHTEISTON LIITÄNTÄ (kuva 4):

- 1) Moottorin laippa
- 2) Vauhtipyörä
- 3) Elastinen kytkin
- 4) Käyttöakseli
- 5) Vaihteiston laippa
- 6) Vauhtipyörän kotelo

Maksimi radiaalinen ja aksiaalinen poikkeama X: K- 0,1 mm

## • VAIHTEISTON JA POTKURIAKSELIN LIITÄNTÄ (kuva 5 - 6):

- Valitse sopiva jäähdyttäjä

Lisätietoja on saatavilla asennuskäsikirjasta.

**Öljyn tyyppi:** ATF (Automatic Transmission Fluid) Automaattivaihteistolle sopiva öljy. Katso luku 10.1.

## 5.1 Käyttö

Kaikki ZF vaihteistot on koekäytetty ennen toimitusta. Normaalisissa käytössä suunnan vaihto on sallittua vain moottorin tyhjäkäynnillä.

Hätätapauksissa se on kuitenkin sallittua myös suuremmilla kierrosluvuilla. Kiertäjärjestelmä toimii asianmukaisesti vain, jos vaihteistoöljy vaihdetaan säännöllisesti määräaikaishuollon yhteydessä. Katso luku 6.1.

Ajoittain on tarkistettava ettei öljyvuotoa esiinny.



### VAROITUS

Toimenpiteet vaihteistolle ovat sallittuja vain kun moottori ei ole käynnissä ja potkuri ei pyöri.



### HUOMIO

Vaihteisto on täytettävä vaihteistoöljyllä ennen käyttöönottoa. Oheet täyttömenettelylle, öljytyypille ja sen määrälle löytyvät luvuista 6.1.4.



### HUOMIO

Vaihteiston käyttö ilman tarpeellista öljymäärää vaurioittaa hammaspyöriä. Liiallinen öljymäärä voi aiheuttaa öljyn vuotoa tiivisteistä ja huohottimesta ja saattaa nostaa huomattavasti käyttölämpötilaa.

## 5.1.1 KÄYTTÖ



### HUOMIO

Ennen vaihteiston käyttöä tarkista öljyn määrä (katso luku 6.1.1).



### HUOMIO

Normaalissa käytössä suunnan vaihtaminen on sallittua vain moottorin ollessa tyhjäkäynnillä. Suunnan vaihtaminen korkeammilla kierroksilla voi johtaa kytkinlevyjen ylikuormitukseen ja sitä pitäisi välttää normaaliolosuhteissa.

**HUOMAUTUS:** Suunnan vaihtaminen eteenpäinajosta taaksepäinajoon on mahdollista hätätapauksissa myös korkeammilla kierrosluvuilla.

## KÄYTTÖASENNOT (kuva 7):

A = Potkurin pyörimissuunta vastakkainen moottorin pyörimissuuntaan nähden

N = Vapaa-asento

B = Potkurin pyörimissuunta sama kuin moottorin



### VAROITUS

Käynnistä moottori vain vaihteen ollessa vapaalla.

Käyttölämpötila olisi pidettävä 50-80°C:ssa. Öljyn maksimilämpötilassa, 100 °C, vaihteistoa saa käyttää vain lyhytaikaisesti.



### HUOMIO

Jos öljyn lämpötila on liian korkea sammuta moottori välittömästi ja tarkista öljyn määrä sekä jäähdyttäjän toiminta.

Älä käynnistä moottoria uudelleen ennen kuin vika on korjattu.

## 5.1.2 PURJEHDUS, HINAUS TAI ANKKUROINTI

Kun moottori on pysähdyksissä ja aluksella purjehditaan, sitä hinataan tai se on ankkuroituna, potkuri saattaa pyöriä virtauksen vaikutuksesta.

Tämä ei aiheuta vaaraa vaihteistolle.

Aluksessa jossa on kaksi moottoria, ei käytössä olevan vaihteiston potkuri saattaa pyöriä vapaasti. Kun moottori on pysähdyksissä vaihteensiirtovivun asennolla ei ole merkitystä.



### HUOMIO

Potkurin vapaa-asento: vaihteensiirtovivun on oltava asennossa N (kuva 7). Jos potkurin pyöriminen halutaan estää on vivun asennon oltava päinvastainen kuin eteenpäin ajettaessa, muutoin vaihteisto voi vaurioitua



### VAROITUS

Toimenpiteet vaihteistolle eivät ole sallittuja aluksen ollessa hinauksessa tai jokeen ankkuroituna koska tällöin potkuri saattaa pyöriä.



### VAROITUS

Toimenpiteet vaihteistolle aluksessa, jossa on kaksi moottoria eivät ole sallittuja kun toinen moottoreista on käynnissä. Pysähdyksissä olevan moottorin potkuri saattaa pyöriä.



### VAROITUS

Jos halutaan potkurin pysyvän paikoillaan moottorin minimikierrosnopeudella (esim. ladattaessa akkua generaattorilla), vaihteensiirtovivun on oltava vapaa-asennossa (N) jotta alus ei liiku (kuva 12). Vältä hydraulisen vaihteiston pitkäaikaista käyttämistä vapaa-asennossa korkeilla moottorin kierrosnopeuksilla.

## 5.1.3 VAIHTEISTON KÄYTTÖ



### HUOMIO

Varmista että työntövetokaapelin liikkeelle ei ole esteitä

## VAIHTSENSIIRTOVIVUN LIIKEMATKA

Mod: ZF 5 M - 6 M - 10 M - 12 M - 15 M  
- 15 MA - 15 MIV - 25 M - 25 MA  
- 30 M.



Vaihteensiirtovivun minimiliikematka (N-A=N-B) ulomalle kiinnitysreiälle täytyy olla vähintään 35 mm ja sisemmälle kiinnitysreiälle vähintään 30 mm.

#### kuva 8:

- 1) Kiristysmomentti  $22 \pm 1$  Nm.
- 2) Kaapelin minimi liikematka
- 3) **Älä avaa kantta**
- 4) Öljyntyhjennystulppa  
Kiristysmomentti:  $Ma = 22$  Nm (16 lb-ft).

#### VAIHTEENSIIRTOVIVUN LIIKEMATKA:

Mod: **ZF 4-1 M**

Vaihteensiirtovivun minimiliikematka (N-A=N-B) ulomalle kiinnitysreiälle täytyy olla  $38,5 \pm 1,5$  mm ja sisemmälle kiinnitysreiälle  $33,5 \pm 1,5$  mm neutraalista asennosta. Kun vivun liike saavuttaa 10-12 asteen kulman liikkuu se sen lisäksi maksimissaan 40 asteen kulmaan.

#### kuva 9:

- 1) Kiristysmomentti  $22 \pm 1$  Nm.
- 2) Älä avaa mutteria
- 3) **Älä avaa kantta**

**VAIHTEENSIIRTOVIVUN ASETO:** neutraaliasennossa kohtisuorassa työntövetokaapeliin nähden.

Vaihteensiirtovivun voi asentaa haluttuun asentoon ja kiristää sen sitten kiinnitysruuvien avulla. Välys vaihteensiirtovivun ja sen kannen välillä tulee olla vähintään 0,5 mm. Jos vaihteensiirtovivun kansi avataan tai sen ruuveja löysätään se pitää sen jälkeen säätää uudelleen (vain ammattihenkilöiden toimesta).

#### kuva 10:

- 1) Öljyn mittatikku ja täyttöaukko (M 17)  
Kiristysmomentti :  $Ma = 20$  Nm (15 lb-ft).
- 2) Vaihdevivun välys min 0,5 mm

**TARKISTUKSET:** Tarkista säännöllisesti vivun asento, jotta toiminta on asianmukaista.

## 6.1 Huolto

### 6.1.1 ÖLJYN MÄÄRÄN TARKISTUS



#### VAROITUS

**Toimenpiteet eivät ole sallittuja aluksen ollessa hinauksessa tai jokeen ankkuroituna koska tällöin potkuri saattaa pyöriä.**

#### ÖLJYN MITTATIKUN KUVAUS (kuva 11):

- 1) Kotelon yläpinta
- 2) Mittatikku
- 3) Öljytaso
- 4) ATF-öljy
- 5) Tiivisterengas.

Vaihteiston öljyn määrä voidaan tarkistaa öljyn ollessa joko kylmää tai lämmintä.

**HUOMAUTUS:** Tarkista öljyntaso aina ennen suunnanvaihtimen ensimmäistä käyttöönottoa. Toimi seuraavasti.

- Irrota mittatikku (kuva 11) kiertämällä kahvaa vastapäivään.
- Pyyhi mittatikku puhtaalla ja pölyttömällä rievulla.
- Aseta mittatikku reikään kiertämättä sitä kierteille. Nosta se ylös ja tarkista öljyn määrä: öljyn määrä pitää olla minimi- ja maksimimerkin välillä (3-4 kuva 11).
- Aseta mittatikku takaisin paikalleen ja lukitse se kiertämällä myötäpäivään.



#### HUOMIO

**Moottorin pysäyttämisen jälkeen tietty määrä voiteluöljyä virtaa takaisin vaihteistoon. Öljyn määrä riippuu jäähdyttäjän tyypistä ja asennustavasta sekä kiertojärjestelmästä. Pitkän seisonta-ajan jälkeen vaihteiston öljymäärä saattaa täten ylittää maksimirajan. Öljyä ei saa poistaa, vaan on toimittava seuraavasti.**

- Moottoria on käytettävä tyhjäkäynnillä ja suunnanvaihtovivun on oltava

vapaa-asennossa kunnes jäähdyttäjä ja öljyputket ovat täynnä öljyä.

- Pysäytä moottori ja tarkista öljyn määrä välittömästi. Jos tarpeellista, vähennä öljyn määrää kunnes se on mittatikun minimi- ja maksimimerkin välissä (kuva 11). Tarkista öljyn määrä uudestaan lyhyen käyttöajan jälkeen.

### 6.1.2 ÖLJYN VAIHTO



#### HUOMIO

**Ensimmäinen vaihto tulisi suorittaa 25 käyttötunnin jälkeen. Sen jälkeen öljy pitää vaihtaa 300 käyttötunnin välein tai kerran vuodessa (riippuen siitä mikä tapahtuu ensin).**



#### HUOMIO

**Jäteöljyä tulee käsitellä erikoisjätteenä, joka saastuttaa ympäristöä: se tulee toimittaa jätteiden lajittelukeskukseen.**

### 6.1.3 ÖLJYN POISTO

Poista tulppa (1 kuva 12) ja valuta öljy kotelon alaosassa olevan reiän kautta.

### 6.1.4 TÄYTTÖ ATF-ÖLJYLLÄ

Täytä automaattivaihteistoille tarkoitettulla ATF-öljyllä, noudata annettuja määriä. Lisää tarvittava määrä täyttääksesi lämmönvaihtimen ja sen liitosputket.

ZF 4-1 M: .....	0,42 litraa
ZF 5 M: .....	0,42 litraa
ZF 6 M: .....	0,42 litraa
ZF 10 M: .....	0,42 litraa
ZF 12 M: .....	0,60 litraa
ZF 15 M: .....	0,60 litraa
ZF 15 MA: .....	0,56 litraa
ZF 15 MIV: .....	1,00 litraa
ZF 25 M: .....	0,75 litraa
ZF 25 MA: .....	0,75 litraa
ZF 30 M: ...min. 0,90-maks.1,10 litraa	

- Akselin kallistuksen ollessa alle 20° (15° ZF MIV).

Käytä ainoastaan automaattivaihteistoöljyä «Suositeltujen öljyjen luettelon» määrittelyjen mukaan, s 82.



### 6.1.5 KOEKÄYTTÖ

- 1) Suorita koekäyttö öljynvaihdon jälkeen.
- 2) Aseta suunnanvaihtovipu vapaasentoon (N). Käynnistä moottori ja anna sen tyhjäkäydä hetken jotta jäähdyttävä ja putket täyttyisivät öljyllä.

- 3) Pysäytä moottori ja tarkista uudelleen öljyn määrä. Lisää öljyä jos se on tarpeen. Liika öljy pitää poistaa. Öljyn korkeus mittatikussa pitää olla minimi- ja maksimimerkin välissä. Öljyn määrä täytyy tarkistaa uudelleen lyhyen käyttöajan jälkeen.

### 6.1.6 SÄILYTYS

Jos vaihteisto on varastossa pitemmän aikaa, esim. talvisäilössä se pitää täyttää kokonaan ATF- öljyllä ruostumisen estämiseksi.



**HUOMIO**

**Vaihda öljy ennen käyttöön ottoa.**

## 7.1 Vianetsintä

Tarkista ensin että käyttöohjeita on noudatettu.

VIKA	MAHDOLLINEN SYY	TOIMENPITEET
1. Öljyn korkea lämpötila	<ul style="list-style-type: none"> <li>- Öljyn taso liian korkea.</li> <li>- Öljyn taso liian alhainen</li> <li>- Jäähdytin tukkeutunut</li> <li>- Ei vettä jäähdytinkierrossa mahdollinen vuotokohta.</li> </ul>	<ul style="list-style-type: none"> <li>- Vähennä öljymäärää maksimimerkkiin asti</li> <li>- Lisää öljyä</li> <li>- Vaihda tai puhdista jäähdytin ja tarkista veden kierto</li> <li>- Tarkista veden kierto ja korjaa</li> </ul>
2. Öljyä vaihdekotelon päällä	<ul style="list-style-type: none"> <li>- Ruuveja ei riittävästi kiristetty</li> <li>- Letkuliittimet vuotavat</li> <li>- Öljyn mittatikku on irronnut</li> <li>- Öljyn taso liian korkea käytön aikana.</li> </ul>	<ul style="list-style-type: none"> <li>- Kiristä ruuvit oikeaan momenttiin</li> <li>- Kiristä liittimet</li> <li>- Kiinnitä mittatikku</li> <li>- Vähennä öljymäärää maksimimerkkiin asti.</li> </ul>
3. Vaihteenvältsin on liian jäykkä	<ul style="list-style-type: none"> <li>- Viallinen suunnanvaihtomekanismi</li> <li>- Kaukohallintalaitteen väärä säätö</li> </ul>	<ul style="list-style-type: none"> <li>- Ota yhteys ammattiin</li> <li>- Tarkista ja säädä kaukohallintalaitte</li> </ul>
4. Vaihte kytkeytyy hitaasti	<ul style="list-style-type: none"> <li>- Viallinen suunnanvaihtomekanismi</li> <li>- Kaukohallintalaitteen väärä säätö</li> </ul>	<ul style="list-style-type: none"> <li>- Ota yhteys ammattiin</li> <li>- Tarkista ja säädä kaukohallintalaitte</li> </ul>
5. Alus ei liiku	<ul style="list-style-type: none"> <li>- Viallinen suunnanvaihtomekanismi</li> <li>- Suunnanvaihtovivun väärä asento</li> <li>- Potkuri irronnut</li> <li>- Potkuri akseli rikkoutunut</li> <li>- Vaihteisto viallinen</li> <li>- Moottori viallinen</li> </ul>	<ul style="list-style-type: none"> <li>- Ota yhteys ammattiin</li> <li>- Säädä vipu oikeaan asentoon</li> <li>- Asenna uusi potkuri</li> <li>- Ota yhteys ammattiin</li> <li>- Ota yhteys ammattiin</li> <li>- Ota yhteys ammattiin</li> </ul>



## 8.1 Tekniset tiedot

### Technical Data for Pleasure Craft Duty

Based on engine power B to DIN 6270; shock factor

K = 1.25 to be applied, if engine has 1 cylinder / K = 1.20 for 2 cylinders / K = 1.15 for 3 cylinders

MODEL	RATIO		POWER / RPM		INPUT POWER CAPACITY						MAX RPM	WEIGHT		BELL HSGS. AND NOTES
	«A» Pos	«B»Pos	kW	hp	kW	hp	kW	hp	kW	hp		kg	lb	
					2800 rpm	3000 rpm	3600 rpm							
ZF 5 M	2.045	1.864	0.0066	0.0088	18	25	20	27	20	27	8.5	19	SAE 6, B/W Max input power 20 kW	
	2.722	2.150	0.0047	0.0063	13	18	14	19	17	23				5000

K = 1.25 to be applied, if engine has 1 cylinder / K = 1.20 for 2 cylinders / K = 1.15 for 3 cylinders

MODEL	RATIO		POWER / RPM		INPUT POWER CAPACITY						MAX RPM	WEIGHT		BELL HSGS. AND NOTES
	«A» Pos	«B»Pos	kW	hp	kW	hp	kW	hp	kW	hp		kg	lb	
					2800 rpm	3000 rpm	3600 rpm							
ZF 6 M	2.045	1.864	0.0066	0.0088	18	25	20	27	20	27	10.3	23	SAE 4, 5, 6, B/W Max input power 20 kW	
	2.722	2.150	0.0047	0.0063	13	18	14	19	17	23				5000

K = 1.25 to be applied, if engine has 1 cylinder / K = 1.20 for 2 cylinders / K = 1.15 for 3 cylinders

\*\* Max. 95 Nm (70 ft lb) admissible for main travelling direction with gear lever set to «B»

MODEL	RATIO		POWER / RPM		INPUT POWER CAPACITY						MAX RPM	WEIGHT		BELL HSGS. AND NOTES
	«A» Pos	«B»Pos	kW	hp	kW	hp	kW	hp	kW	hp		kg	lb	
					2800 rpm	3000 rpm	3600 rpm							
ZF 10 M	1.482	1.864	0.0109	0.0146	30	41	33	44	38	51	10.3	23	SAE 4, 5, 6, B/W Max input power 38 kW. <b>Ratio 1.482 «B» Pos.</b> <b>max torque 95 Nm. Ratio</b> <b>1.792 «B» Pos. max</b> <b>torque 95 Nm.</b>	
	1.792	1.864												
	2.045	1.864	0.0095	0.0128	27	36	29	38	34	46				5000
	2.722	2.150	0.0068	0.0091	19	26	20	27	25	33				5000

K = 1.25 to be applied, if engine has 1 cylinder / K = 1.20 for 2 cylinders / K = 1.15 for 3 cylinders

MODEL	RATIO		POWER / RPM		INPUT POWER CAPACITY						MAX RPM	WEIGHT		BELL HSGS. AND NOTES
	«A» Pos	«B»Pos	kW	hp	kW	hp	kW	hp	kW	hp		kg	lb	
					2800 rpm	3000 rpm	3600 rpm							
ZF 12 M	2.136	1.955	0.0131	0.0176	37	49	39	53	47	63	13	29	SAE 4, 5, 6, B/W, Yanmar JH Max input power 55 kW	
	2.632	1.955	0.0111	0.0149	31	42	33	45	40	54				5000

K = 1.25 to be applied, if engine has 1 cylinder / K = 1.20 for 2 cylinders / K = 1.15 for 3 cylinders

\*\* Max. 120 Nm (88.5 ft lb) admissible for main travelling direction with gear lever set to «B»

MODEL	RATIO		POWER / RPM		INPUT POWER CAPACITY						MAX RPM	WEIGHT		BELL HSGS. AND NOTES
	«A» Pos	«B»Pos	kW	hp	kW	hp	kW	hp	kW	hp		kg	lb	
					3000 rpm	3600 rpm	3800 rpm							
ZF 15 M	1.556	1.955	0.0152	0.0204	46	61	55	73	55	74	13	29	SAE 4, 5, 6, B/W, Yanmar JH Max input power 55 kW. <b>Ratio 1.556 «B» Pos.</b> <b>max torque 120 Nm.</b> <b>Ratio 1.875 «B» Pos.</b> <b>max torque 120 Nm.</b>	
	1.875	1.955												

«A» POS = continuous running position (normally AHEAD).

«B» POS = reverse position.

B/W = Borg Warner adaptor.

Note = For all «M» (Mechanical) transmissions reduce power capacity by the following shock factors: 1 cylinder engine ÷ 1.25, 2 cylinder engine ÷ 1.20, 3 cylinder engine ÷ 1.15.



## Käyttö ja Huolto ZF 4-1 M / ZF 30 M

**K = 1.25 to be applied, if engine has 1 cylinder / K = 1.20 for 2 cylinders / K = 1.15 for 3 cylinders**

\*\* Max. 120 Nm (88.5 ft lb) admissible for main travelling direction with gear lever set to «B»

MODEL	RATIO		POWER / RPM		INPUT POWER CAPACITY						MAX RPM	WEIGHT		BELL HSGS. AND NOTES
	«A» Pos	«B»Pos	kW	hp	kW	hp	kW	hp	kW	hp		kg	lb	
					3000 rpm	3600 rpm	3800 rpm							
ZF 15 MA 8 degrees	1.875	1.955	0.0152	0.0204	46	61	55	73	55	74	13.5	30	SAE 4, 5, 6, B/W, Yanmar JH Max input power 55 kW. <b>Ratio 1.875 «B» Pos. max torque 120 Nm. Ratio 2.136 «B» Pos. max torque 120 Nm.</b>	
	2.136	1.955	0.0131	0.0176	39	53	47	63	50	67				
	2.632	1.955	0.0111	0.0149	33	45	40	54	42	57				

**K = 1.25 to be applied, if engine has 1 cylinder / K = 1.20 for 2 cylinders / K = 1.15 for 3 cylinders**

\* Max. 120 Nm (88.5 ft lb) admissible for main travelling direction with gear lever set to «B».

\*\* Max 45 kW for main travelling direction with gear lever set to «B».

MODEL	RATIO		POWER / RPM		INPUT POWER CAPACITY						MAX RPM	WEIGHT		BELL HSGS. AND NOTES
	«A» Pos	«B»Pos	kW	hp	kW	hp	kW	hp	kW	hp		kg	lb	
					3000 rpm	3600 rpm	3800 rpm							
ZF 15 MIV 8 degrees	2.134	2.224	0.0152	0.0204	46	61	55	73	55	74	21	47	SAE 4, 5, B/W, Yanmar JH Max input power 55 kW. <b>Ratio 2.134 «B» Pos. max torque 120 Nm.</b>	
	2.718	2.224	0.0111	0.0149	33	45	40	54	42	57				
	2.995	2.224												

**K = 1.25 to be applied, if engine has 1 cylinder - K = 1.20 for 2 cylinders - K = 1.15 for 3 cylinders**

\*\* Max. 230 Nm (170 ft lb) admissible for main travelling direction with gear lever set to «B»

MODEL	RATIO		POWER / RPM		INPUT POWER CAPACITY						MAX RPM	WEIGHT		BELL HSGS. AND NOTES
	«A» Pos	«B»Pos	kW	hp	kW	hp	kW	hp	kW	hp		kg	lb	
					3000 rpm	3600 rpm	3800 rpm							
ZF 25 M	1.880	2.095	0.0262	0.0351	79	105	80	107	80	107	18.5	41	SAE 4, 5, B/W, Yanmar JH Max input power 80 kW. <b>Ratio 1.880 «B» Pos. max torque 230 Nm.</b>	
	2.273	2.095	0.0216	0.0289	65	87	78	104	80	107				
	2.737	2.722	0.0177	0.0237	53	71	64	85	67	90				

**K = 1.25 to be applied, if engine has 1 cylinder / K = 1.20 for 2 cylinders / K = 1.15 for 3 cylinders**

\*\* Max. 169 Nm (125 ft lb) admissible for main travelling direction with gear lever set to «B»

MODEL	RATIO		POWER / RPM		INPUT POWER CAPACITY						MAX RPM	WEIGHT		BELL HSGS. AND NOTES
	«A» Pos	«B»Pos	kW	hp	kW	hp	kW	hp	kW	hp		kg	lb	
					3000 rpm	3600 rpm	3800 rpm							
ZF 25 MA 8 degrees	2.227	2.737	0.0215	0.0288	64	86	77	104	80	107	21.1	47	SAE 4, 5, B/W, Yanmar JH Max input power 80 kW. <b>Ratio 2.227 «B» Pos. max torque 169 Nm.</b>	
	2.737	2.737	0.0177	0.0237	53	71	64	85	67	90				

**K = 1.25 to be applied, if engine has 1 cylinder / K = 1.20 for 2 cylinders / K = 1.15 for 3 cylinders**

\*\* Max. 185 Nm (137 ft lb) admissible for main travelling direction with gear lever set to «B»

MODEL	RATIO		POWER / RPM		INPUT POWER CAPACITY						MAX RPM	WEIGHT		BELL HSGS. AND NOTES
	«A» Pos	«B»Pos	kW	hp	kW	hp	kW	hp	kW	hp		kg	lb	
					3000 rpm	3600 rpm	3800 rpm							
ZF 30 M	2.148	2.636	0.0241	0.0323	72	97	87	116	92	123	23	51	4 & 5 Yanmar JH Max input power 95 kW. <b>Ratio 2.148 «B» Pos. max torque 185 Nm. Ratio 2.696 «B» Pos. max torque 185 Nm.</b>	
	2.696	2.636												

«A» POS = continuous running position (normally AHEAD).

«B» POS = reverse position.

B/W = Borg Warner adaptor.

Note = For all «M» (Mechanical) transmissions reduce power capacity by the following shock factors: 1 cylinder engine ÷ 1.25, 2 cylinder engine ÷ 1.20, 3 cylinder engine ÷ 1.15.



## 9.1 Takuu

### 9.1.1 NORMAALI TAKUU

ZF Marine Arco S.p.A. antaa ZFM merivaihteistolleen täyden materiaali- ja valmistustakuun ainoastaan sillä edellytyksellä että laite on asennettu oikein ja sitä on käytetty asianmukaisesti.

ZF Marine Arco S.p.A. velvollisuus tämän takuun puitteissa rajoittuu ZF Marine Arco S.p.A. tutkimuksessa vialliseksi havaittujen osien vaihtamiseen tai korjaukseen siinä tapauksessa että osa tai osat ovat palautettu lähimmälle ZF Marine Arco S.p.A. edustajalle rahti etukäteen maksettuna seuraavan määrääjän kuluessa:

24 (kaksikymmentäneljä) kuukautta veneen käyttöön otosta tai 36 (kolmekymmentäkuusi) kuukautta toimintuksesta tehtaalta, riippuen siitä mikä tapahtuu ensiksi.

ZF Marine Arco S.p.A. takuuvollisuudet ovat voimassa sillä edellytyksellä että myös tuotteen edustaja ja moottorinvalmistaja, joka on ostanut vaihteiston, noudattavat virallista takuumenettelyä, joka on osa takuuta.

Kaikki takuuvaatimukset tulee esittää ZF:n edustajalle tai moottorinvalmistajalle joka on ostanut ZF vaihteiston.

Takuu ei ole voimassa siinä tapauksessa että johonkin laitteen osaan tai sen osiin on tehty korjauksia tai muutoksia joita virallinen ZF-edustaja ei ole kirjallisesti valtuuttanut.

Tämä takuu ei ole voimassa silloin jos laitetta tai sen osia on käytetty väärin

tai huolimattomasti, siihen on tehty muutoksia tai se on vaurioitunut onnettomuudessa. Takuu ei ole voimassa myöskään, jos laitteen käytössä ei ole noudatettu ZF:n kirjallisia käyttöohjeita tai sitä on käytetty vaikeammassa olosuhteissa kuin ohjeissa on sallittu tai ylittämällä jollain tavalla laitteen käytölle määritellyt rajat, tai se on asennettu väärin tai sitä on käytetty tai huollettu epäasianmukaisesti.

Nämä takuuehdot korvaavat kaikki muut suorat ja epäsuorat takuuehdot, jotka sisältävät myynti- ja käyttötakuun, sekä mahdolliset muut velvoitteet jotka koskevat käytöstä aiheutuneita vaurioita.

ZF Marine Arco S.p.A. ei ota vastuuta mistään muista mahdollisista lisävelvoitteista jotka koskevat ZFM merivaihteiston myyntiä, eikä ole valtuuttanut ketään ottamaan tällaista vastuuta ZF Marine Arco S.p.A. nimissä.

ZF Marine Arco S.p.A. ei missään olosuhteissa vastaa vahingoista, jotka ylittävät ZFM merivaihteiston ostohinnan.

### 9.1.2 VÄÄNTÖVÄRÄHTELY-VASTUU JA VÄRÄHTELYÄ VAIMENTAVAT KYTKIMET

Vastuu vääntöväärähtelystä on vaihteiston ja voimansiirron komponenttien käyttöönottajalla. ZF Marine Arco S.p.A. ei vastaa melusta, joka aiheutuu värähtelystä tai värähtelyn aiheuttamasta vahingosta vaihteistolle,

elastiselle kytkimelle tai muille vaihteiston osille. Ota yhteys lisätietojen ja avun saamiseksi.

ZF Marine Arco S.p.A. suosittelee käyttämään mekaanista väännönrajoitinta elastisessa kytkimessä yhdellä moottorilla varustetuissa veneissä, joissa vedon katkeaminen voi aiheuttaa veneen hallinnan menettämisen. Ostajalla on vastuu päättää tämän lisäominaisuuden hankinnasta, joka voi aiheuttaa lisäkustannuksia tai mahdollisesti pidentää vaihteiston rakennetta.

ZF Marine Arco S.p.A. ei vastaa loukkaantumisesta, kuolemantapauksesta tai vahingosta omaisuudelle, mikäli ostaja ei ole määritellyt mekaanisen väännönrajoittimen käyttövaatimusta elastisessa kytkimessä.

ZF Marine Arco S.p.A. valitsee värähtelyä vaimentavat elastiset kytkimet moottorin nimellisvääntömomenttien ja yleisesti hyväksytyjen nimelliskierroslukujen perusteella.

Tiedustele ZF Marine Arco S.p.A.:ltä standardi elastisten kytkinten kierroslukurajoista, jotka saattavat olla alhaisempia kuin vaihteiston vastaavat rajat. Luokituslaitosten jääluokkavaatimukset saattavat edellyttää erikoismallisen elastisen kytkimen käyttöä.

## ΕΛΙΝΙΚΑ

### Πίνακας Περιεχομένων

1.1	Εισαγωγή.....	68
2.1	Αναγνώριση ρεβέρσας.....	68
3.1	Περιγραφή.....	68
4.1	Εγκατάσταση.....	68
5.1	Λειτουργία.....	69
6.1	Συντήρηση.....	70
7.1	Ανίχνευση βλαβών.....	71
8.1	Τεχνικά δεδομένα.....	72
9.1	Εγγύηση.....	74
10.1	ATF.....	82
11.1	Κατάλογος Διανομένων.....	83
12.1	Καρτέλα εγγύησης.....	84
13.1	Warranty Card.....	95

## 1.1 Εισαγωγή

### 1.1.1 Ευθύνη Πελάτη

Ο πελάτης/χειριστής είναι υπεύθυνος για την εκτέλεση των αναγκαίων ελέγχων ασφαλείας για τη διασφάλιση τήρησης των απαιτούμενων κανόνων λίπανσης, ψύξης, συντήρησης για την ασφαλή, και απολαυστική λειτουργία.

Όλες οι ρεβέρσες καλύπτονται από εγγύηση. Κατά συνέπεια: Θα πρέπει να τηρούνται αυστηρά οι κανόνες χειρισμού των μηχανισμών της ρεβέρσας που περιλαμβάνονται στο βιβλίο αυτό.



#### ΠΡΟΣΟΧΗ

Ο κατασκευαστής δεν φέρει ευθύνη για οποιεσδήποτε ζημιές ή απώλειες που προκαλούνται από λαθεμένη εγκατάσταση, λαθεμένο χειρισμό του εξοπλισμού και/ή ελλιπή συντήρηση.

Ο πελάτης πρέπει να φροντίζει για την αποφυγή των οποιωνδήποτε εξωτερικών καταπονήσεων, καθώς επίσης και κραδασμών που προκαλούνται από τις στρεπτικές και καμπικές κινήσεις.

Η αλληλεπίδραση ανάμεσα στη μηχανή, τον ελικοφόρο άξονα και την προπέλα μπορούν να οδηγήσουν σε κραδασμούς που προκαλούνται από τα περιστρεφόμενα τμήματα, οι οποίοι προκαλούν έναν τύπου «σφυροκοπήματος» θόρυβο στα γρανάζια, γεγονός που μπορεί να προκαλέσει ζημιά στην μηχανή και/ή το σύστημα μετάδοσης κίνησης. Ο προμηθευτής δεν φέρει ευθύνη για οποιουδήποτε στρεπτικούς κραδασμούς που έχουν να κάνουν με την εγκατάσταση.

Το εγχειρίδιο αυτό περιλαμβάνει, μεταξύ άλλων, και τα ακόλουθα κύρια κεφάλαια:

### 1.1.2 Περιγραφή

Αυτό το τμήμα περιγράφει εν συντομία την λειτουργία, τον χειρισμό και την σχεδίαση των μηχανισμάτων τύπου ψψ.

### 1.1.3 Λειτουργία

Το τμήμα αυτό περιγράφει τις διαδικασίες για τη λειτουργία καθώς και όλα τα αναγκαία μέτρα ασφαλείας.

### 1.1.4 Συντήρηση

Το τμήμα αυτό περιέχει όλες τις εργασίες συντήρησης και επισκευής που εκτελούνται από το χειριστή.

Οποτεδήποτε χρησιμοποιούνται οι λέξεις «δεξιά, αριστερά» στο βιβλίο αυτό, θα αναφέρονται πάντοτε στην εγκατεστημένη ρεβέρσα όταν κινείται με κίνηση πρόσω. Σημαντικές πληροφορίες που αναφέρονται στην τεχνική αξιοπιστία και την ασφάλεια λειτουργίας επισημαίνονται με τις κατάλληλες λέξεις αναγνώρισης ως ακολούθως:



#### ΠΡΟΕΙΔΟΠΟΙΗΣΗ

**Οποιαδήποτε διαδικασία, μέθοδος, κατάσταση, δήλωση κτλ, η οποία δεν ακολουθείται πιστά και η οποία θα μπορούσε να προκαλέσει τραυματισμό ή και θάνατο του προσωπικού.**



#### ΠΡΟΣΟΧΗ

**Οποιαδήποτε διαδικασία, μέθοδος, κατάσταση, δήλωση, κτλ η οποία δεν τηρείται όπως πρέπει, και η οποία θα μπορούσε να προκαλέσει ζημιά ή και ολοσχερή καταστροφή του εξοπλισμού.**

**Σημείωση:** Ισχύει για την τεχνική απαίτηση στην οποία ο χειριστής του εξοπλισμού πρέπει να εφιστά ιδιαίτερως την προσοχή του.

Οι λέξεις **ΠΡΟΕΙΔΟΠΟΙΗΣΗ**, **Προσοχή** και **Σημείωση** προηγούνται πάντοτε του κειμένου στο οποίο αναφέρονται.

### 2.1 Αναγνώριση ρεβέρσας

Η πινακίδα προσδιορισμού βρίσκεται στη ρεβέρσα. Στην Εικ. 1 παρουσιάζεται παράδειγμα πινακίδας προσδιορισμού:

- D** Σχέση μετάδοσης, φορά περιστροφής προπέλας αντίθετη από εκείνη της μηχανής
- A** Αριθμός σειράς κιβωτίου οδοντωτών τροχών

**E** Κάθε χρόνο εκχωρείται ένα καινούριο γράμμα με αύξουσα σειρά.

**B** Κωδικός κιβωτίου οδοντωτών τροχών

**E** Έκδοση κιβωτίου οδοντωτών τροχών

**C** Σχέση μετάδοσης, φορά περιστροφής προπέλας ίδια με εκείνη της μηχανής

**F** Τύπος κιβωτίου ταχυτήτων  
**Σημασία των συμβόλων που χρησιμοποιούνται για το κιβώτιο οδοντωτών τροχών:**

**G** Τύπος κιβωτίου ταχυτήτων

**H** Μέγεθος κιβωτίου οδοντωτών τροχών

**I** Έκδοση κιβωτίου οδοντωτών τροχών

## 3.1 Περιγραφή

Ο πελάτης/χειριστής είναι υπεύθυνος για την εκτέλεση των αναγκαίων ελέγχων ασφαλείας για να σιγουρευτείτε ότι τηρούνται οι προβλεπόμενοι κανόνες λίπανσης, ψύξης, συντήρησης και οι προτεινόμενες μέθοδοι για την ασφαλή, και ευχάριστη λειτουργία.

Όλες οι ρεβέρσες καλύπτονται από μία περιορισμένη εγγύηση.

Κατά συνέπεια:

Θα πρέπει να τηρούνται αυστηρά οι περιγραφόμενοι κανόνες χειρισμού των μηχανισμών της ρεβέρσας.

Σχήμα 2:

- 1) Ψυγείο.
- 2) Φλάντζα εξόδου.
- 3) Πινακίδα αναγνώρισης.
- 4) Μοχλός ελέγχου.
- 5) Στήριγμα τηλεχειρισμού.
- 6) Καμπάνα.
- 7) Άξονας εισόδου
- 8) Δείκτης λαδιού.

## 4.1 Εγκατάσταση

Κατά την τοποθέτηση της ρεβέρσας τύπου ZFM, θα πρέπει να σημειώσετε ιδιαίτερα τα ακόλουθα σημεία:

- Η τοποθέτηση πρέπει να γίνει μόνο από ειδικούς
- **Εγκατάσταση υπό κλίση:(Σχήμα 3):**

Η θέση του κιβωτίου ως προς τον άξονα εισόδου δεν πρέπει να υπερβαίνει τη γωνία των 20° (15° για ZF MIV), σε συνεχή λειτουργία. Για την όποια πλευρική επιτρεπτή κλίση απαιτείται σχετική έγκριση του κατασκευαστή κατόπιν αιτήσεως.

- Σύνδεσμοι: Ελαστικός, ως προς



τη στρέψη, σύνδεσμος με ακτινικό διάκενο 0,5 mm, που απαιτείται πλευρικά της μηχανής: στο πλάι της έλικας απαιτείται ευέλικτος ελαστικός σύνδεσμος.

• **Σύνδεση μηχανής-ρεβέρσας (Σχήμα 4):**

- 1) Φλάντζα κινητήρα.
- 2) Στρόφαλος.
- 3) Ελαστικός σύνδεσμος.
- 4) Άξονας ρεβέρσας.
- 5) Φλάντζα ρεβέρσας.
- 6) Φλάντζα στροφάλου.

Μέγιστες επιτρεπτές ακτινικές και αξονικές τιμές **X: B-0,1 mm**.

• Σύνδεση άξονα ρεβέρσας-προπέλας (Σχήμα 5 - 6):

• Επιλέξτε ψυγείο με ικανοποιητική ψυκτική ικανότητα

Για περισσότερες πληροφορίες βλέπε το κεφάλαιο που αναφέρεται στην εγκατάσταση του εγχειριδίου.

Τύπος υγρού: ATF (Υγρό αυτόματης ρεβέρσας), βλέπε κεφάλαιο 10.1.

## 5.1 Λειτουργία

Όλα τα κιβώτια οδοντωτών τροχών έχουν περάσει από σκληρά τεστ λειτουργίας προτού παραδοθούν από το εργοστάσιο.

Κατά την διάρκεια της συνήθους λειτουργίας, η αλλαγή ταχύτητας της ρεβέρσας πρέπει να γίνεται μόνον όταν η μηχανή λειτουργεί στο ρελαντί.

Σε έκτακτα περιστατικά είναι επιτρεπτό να γίνεται η αλλαγή ταχυτήτων με υψηλότερες ταχύτητες.

Η σωστή λειτουργία του υδραυλικού κυκλώματος εξασφαλίζεται μόνον εάν αλλάζετε τακτικά τα υγρά, όπως ορίζει η προγραμματισμένη συντήρηση. (Βλ. κεφ.6.1).

Πρέπει κατά καιρούς να γίνονται οπτικοί έλεγχοι για τυχόν διαρροές.



### ΠΡΟΕΙΔΟΠΟΙΗΣΗ

Οι εργασίες στην ρεβέρσα πρέπει να γίνονται μόνον όταν είναι σταματημένη η μηχανή και προπέλα.



### Προσοχή

Πριν από την θέση σε λειτουργία για πρώτη φορά, πρέπει να γεμίζετε την ρεβέρσα με υδραυλικό λάδι.

Σχετικά με την διαδικασία γεμίματος υδραυλικού υγρού, τον τύπο του υδραυλικού υγρού, την ποσότητα και την στάθμη συμβουλευτείτε το κεφάλαιο 6.1.4 που

αναφέρονται στην αλλαγή του υδραυλικού λαδιού.



### Προσοχή

Όταν χρησιμοποιείτε την ρεβέρσα και η στάθμη του λαδιού υπολείπεται της κανονικής τότε θα προκληθούν ζημιές στα γρανάζια. Επίσης όταν η ποσότητα του λαδιού είναι περισσότερη από την κανονική θα προκληθεί διαρροή στις τσιμούχες του άξονα και στο εξαεριστικό της ρεβέρσας με αποτέλεσμα να αυξηθεί η θερμοκρασία λειτουργίας σε μεγάλο βαθμό.

### 5.1.1 Διαδικασία Λειτουργίας



### ΠΡΟΣΟΧΗ

Πριν θέσε σε λειτουργία την ρεβέρσα να ελέγξετε την στάθμη του υδραυλικού υγρού (βλέπε κεφάλαιο 6.1.1).



### ΠΡΟΣΟΧΗ

Κατά την διάρκεια της κανονικής λειτουργίας, θα πρέπει η αλλαγή ταχυτήτων της ρεβέρσας να γίνεται με την μηχανή στο ρελαντί. Η αλλαγή ταχυτήτων με υψηλότερες στροφές της μηχανής μπορεί να προκαλέσει καταπόνηση των δίσκων τριβής του συνδέσμου και γιαυτό θα πρέπει να αποφεύγεται αυτό κατά την κανονική λειτουργία.

**Σημείωση:** Μπορείτε να αλλάξετε από την θέση πρόσω στην θέση ανάποδα σε περίπτωση εκτάκτου ανάγκης ακόμα και όταν οι στροφές της μηχανής είναι υψηλές.

### Θέσεις Αλλαγής Ταχυτήτων (σχήμα 7):

A = περιστροφή προπέλας αντίθετη από την περιστροφή της μηχανής

N = θέση νεκρού σημείου

B = Φορά περιστροφής προπέλας αντίθετη από εκείνη της φοράς περιστροφής της μηχανής.



### ΠΡΟΕΙΔΟΠΟΙΗΣΗ

Να βάζετε μπρος την μηχανή μόνον όταν ο μοχλός της ρεβέρσας είναι στην θέση **ΝΕΚΡΟΥ ΣΗΜΕΙΟΥ**.

Η κανονική θερμοκρασία του λαδιού λειτουργίας της ρεβέρσας πρέπει να κυμαίνεται μεταξύ 50 και

80oC. Η μέγιστη επιτρεπτή θερμοκρασία του λαδιού ATF των 100oC δεν πρέπει να παραμένει για μεγάλο διάστημα παρά μόνο για πολύ λίγο.



### ΠΡΟΣΟΧΗ

Εάν η θερμοκρασία του υγρού είναι πολύ υψηλή, σταματήστε την μηχανή αμέσως και ελέγξτε την στάθμη του υγρού της ρεβέρσας και το ψυγείο λαδιού για την κατάλληλη ροή νερού.

Να μην βάλετε μπρος την μηχανή ξανά, παρά μόνον όταν αποκαταστήσετε την κανονική λειτουργία.

### 5.1.2 ΠΛΕΥΣΗ ΜΕ ΠΑΝΙΑ, ΡΥΜΟΥΛΚΗΣΗ Ή ΑΓΚΥΡΟΒΟΛΙΟ

Όταν ο κινητήρας είναι σβηστός και το σκάφος κινείται με πανιά, ρυμουλκείται ή έχει αγκυροβολήσει, η έλικα μπορεί να περιστρέφεται λόγω των ρευμάτων.

Αυτό δεν δημιουργεί κανένα κίνδυνο για το σύστημα μετάδοσης κίνησης. Στην περίπτωση που τα σκάφος διαθέτει δύο μηχανές, η προπέλα της μη χρησιμοποιούμενης ρεβέρσας μπορεί να περιστρέφεται ελεύθερα (ρελαντί)

Όταν η μηχανή είναι σταματημένη, τότε η θέση του μοχλού αλλαγής ταχυτήτων δεν παίζει κανένα ρόλο.



### ΠΡΟΣΟΧΗ

Θέση λειτουργίας της προπέλας στο ρελαντί: Ο μοχλός αλλαγής ταχυτήτων της ρεβέρσας πρέπει να είναι στη θέση "N" (Σχήμα 7). Χρησιμοποιήστε τη θέση αλλαγής ταχυτήτων που είναι αντίθετα από εκείνη της κίνησης πρόσω για το κλείδωμα του ελικοφόρου άξονα, αλλιώς μπορεί να πάθει ζημιά η ρεβέρσα.



### ΠΡΟΕΙΔΟΠΟΙΗΣΗ

Να μην εργάζεστε στη ρεβέρσα όταν ρυμουλκείτε το σκάφος ούτε να ρίχνετε άγκυρα, γιατί μπορεί να αρχίσει να γυρίζει η προπέλα.



### ΠΡΟΕΙΔΟΠΟΙΗΣΗ

Να μην εργάζεστε στη ρεβέρσα σε σκάφη τα οποία διαθέτουν δύο μηχανές, όταν έχει τεθεί σε λειτουργία η μία μονάδα και αυτό επειδή ο άξονας της προπέλας της ρεβέρσας που δεν λειτουργεί θα αρχίσει να περιστρέφεται.



### ΠΡΟΕΙΔΟΠΟΙΗΣΗ

Όταν η μηχανή λειτουργεί στο ρε-  
λαντί χωρίς όμως να λειτουργεί ο  
ελικοφόρος άξονας (όπως στην  
περίπτωση που γίνεται φόρτιση  
της μπαταρίας με την γεννήτρια),  
ο μοχλός αλλαγής ταχυτήτων  
(σχήμα 7) πρέπει να κρατηθεί στη  
θέση ΝΕΚΡΟΥ ΣΗΜΕΙΟΥ (N) για να  
μην μπορεί να κινηθεί το σκάφος.  
Να αποφεύγετε να χρησιμοποιείτε  
το υδραυλικό κιβώτιο οδοντωτών  
τροχών όταν είναι στην θέση ΝΕ-  
ΚΡΟΥ ΣΗΜΕΙΟΥ σε υψηλές στρο-  
φές της μηχανής για μεγάλο χρο-  
νικό διάστημα.

### 5.1.3 ΣΥΣΤΗΜΑ ΕΛΕΓΧΟΥ



#### ΠΡΟΣΟΧΗ

Βεβαιωθείτε ότι κινείται εύκολα η  
ντίζα μετάδοσης κίνησης.

Μετακίνηση μοχλού χειρισμού:  
**ZF 5 M - 6 M - 10 M - 12 M - 15 M - 15  
MA - 15 MIV - 25 M - 25 MA - 30 M.**  
Η ελάχιστη διαδρομή του μοχλού  
αλλαγής ταχυτήτων (N-A=N-B)  
πρέπει να είναι 35 mm για το εξω-  
τερικό σημείο περιστροφής και 30  
mm για το εσωτερικό σημείο περι-  
στροφής.

#### Σχήμα 8:

- 1) Βίδα στερέωσης μοχλού ροπή  
σύσφιξης  $22 \pm 1$  Nm.
- 2) Ελάχιστη διαδρομή ντίζας μετά-  
δοσης.
- 3) Μη βγάζετε το καπάκι.
- 4) Τάπα εκκένωσης λαδιού.  
Ροπή σύσφιξης: **Ma = 22 Nm (16 lb-ft).**

#### Μετακίνηση μοχλού χειρισμού: ZF 4-1 M

Η διαδρομή του μοχλού αλλαγής  
ταχυτήτων (N-A=N-B) πρέπει να εί-  
ναι  $38,5 \pm$  για το εξωτερικό σημείο  
περιστροφής και  $33,5 \pm 1,5$  mm για  
το εσωτερικό σημείο περιστρο-  
φής, από τη θέση νεκρού σημείου.  
Όταν ο μοχλός περάσει πάνω από  
την γωνία των  $10^\circ-12^\circ$ , αρχίζει να  
κινείται έξω από την κατακόρυφο  
για τον έλεγχο της ντίζας μετάδο-  
σης κίνησης.  
Ο μοχλός αλλαγής ταχυτήτων μπο-  
ρεί να στερεωθεί σε οποιαδήποτε  
θέση μέσω της βίδας σφιξίματος.  
Η ελάχιστη απόσταση μεταξύ του  
μοχλού αλλαγής ταχυτήτων και  
του καπακιού είναι 0,5mm. Απαι-  
τείται ρύθμιση (από ειδικευμένο  
προσωπικό μόνο) του ανοίγματος  
ή της χαλάρωσης του καπακιού.

#### Σχήμα 9:

- 1) Βίδα στερέωσης μοχλού ροπή  
σύσφιξης  $22 \pm 1$  Nm.
- 2) Τάπα εκκένωσης λαδιού.
- 3) Μη βγάζετε το καπάκι.

Θέση μοχλού: Στη θέση νεκρού  
σημείου η οποία είναι κάθετη προς  
τη ντίζα ελέγχου. Ο μοχλός αλλα-  
γής ταχυτήτων μπορεί να στερε-  
ωθεί σε οποιαδήποτε θέση μέσω  
της βίδας σφιξίματος. Η ελάχιστη  
απόσταση μεταξύ του μοχλού αλ-  
λαγής ταχυτήτων και του καλύμ-  
ματος 0,5mm. Για το άνοιγμα ή τη  
χαλάρωση του καλύμματος απαι-  
τείται εκ νέου ρύθμιση (από εξειδι-  
κευμένο προσωπικό μόνο).

#### Σχήμα 10:

- 1) Δείκτης λαδιού και τάπα ανεφο-  
διασμού λαδιού (17 mm)  
Ροπή σύσφιξης: **Ma = 20 Nm (15  
lb-ft).**
- 2) Απόσταση μοχλού ελέγχου από  
το καπάκι ελάχ. **0,5 mm.**

**ΕΛΕΓΧΟΙ:** Για να εξασφαλίζεται η  
σωστή λειτουργία, πρέπει να ελέγ-  
χετε τακτικά τη θέση του μοχλού.

## 6.1 Συντήρηση

### 6.1.1 Έλεγχος στάθμης υδραυλικού υγρού



#### ΠΡΟΕΙΔΟΠΟΙΗΣΗ

**Να μην εργάζεστε στην ρεβέρ-  
σα όταν ρυμουλκείτε το σκάφος  
ή όταν έχετε ρίξει άγκυρα επειδή  
μπορεί να αρχίσει να περιστρέφε-  
ται η προπέλα, ή κατά την πόντιση  
της άγκυρας σε ένα ποτάμι, επει-  
δή μπορεί να αρχίσει να γυρίζει η  
προπέλα.**

#### ΠΕΡΙΓΡΑΦΗ ΔΕΙΚΤΗ ΛΑΔΙΟΥ (Εικ. 11):

- 1) Επιφάνεια κιβωτίου.
- 2) Δείκτης λαδιού.
- 3) Στάθμη λαδιού.
- 4) Λάδι ATF.
- 5) Ροδέλα στεγανότητας.

Η στάθμη του υγρού πρέπει να  
ελεγχθεί ξανά μετά από μικρό χρο-  
νικό διάστημα λειτουργίας.

**ΣΗΜΕΙΩΣΗ:** Ελέγχετε πάντοτε τη  
στάθμη του λαδιού πριν θέσετε σε  
λειτουργία τη ρεβέρσα εφαρμόζο-  
ντας την ακόλουθη διαδικασία.  
- Λασκάρτε τον δείκτη ελέγχου  
στάθμης του υγρού (σχήμα 11)  
γυρίζοντας την λαβή προς τα

αριστερά.

- Σκουπίστε τον δείκτη στάθμης  
λαδιού με ένα καθαρό πανί χωρίς  
ξέφτια
- Τοποθετήστε ξανά τον δείκτη  
ελέγχου στάθμης λαδιού χωρίς  
να τον βιδώσετε. Ξαναβγάλ-  
τε τον δείκτη ελέγχου στάθμης  
λαδιού και ελέγξτε την στάθμη.  
Η στάθμη του λαδιού πρέπει να  
βρίσκεται μεταξύ των σημαδιού  
minimum και maximum (3,4 σχήμα  
11).
- Τοποθετήστε τον δείκτη ελέγχου  
στάθμης λαδιού και ασφαλίστε  
τον περιστρέφοντας την λαβή  
προς τα δεξιά



#### ΠΡΟΣΟΧΗ

**Ανάλογα με τον τύπο και την διά-  
ταξη του ψυγείου και των σωλήνων  
συγκεντρώνεται μία ορισμένη πο-  
σότητα λαδιού μετά το σταμάτημα  
της μηχανής η οποία και επιστρέ-  
φει στην ρεβέρσα μετά από μέγα-  
λο χρονικό διάστημα παραμονής  
εκτός λειτουργίας. Αυτό μπορεί  
να προκαλέσει την υπέρβαση της  
στάθμης του λαδιού στην ρεβέρ-  
σα πέραν του σημαδιού max. Να  
μην αφαιρέσετε την επιπλέον πο-  
σότητα λαδιού, αλλά να προχωρή-  
σετε στα βήματα.**

- Αφήστε την μηχανή να λειτουρ-  
γεί στο ρελαντί με τον μοχλό αλ-  
λαγής ταχυτήτων στην θέση ΝΕ-  
ΚΡΟΥ ΣΗΜΕΙΟΥ, μέχρις ότου το  
ψυγείο του υδραυλικού υγρού  
και όλοι οι σωλήνες γεμίσουν με  
το υγρό.
- Σβήστε την μηχανή και ελέγξτε  
την στάθμη του υγρού σε μικρό  
χρονικό διάστημα. Εάν χρειαστεί,  
συμπληρώστε υγρό για να φέρε-  
τε την στάθμη του υγρού στην  
κανονική θέση στον δείκτη ελέγ-  
χου στάθμης λαδιού.  
Η στάθμη του υγρού στον δεί-  
κτη ελέγχου στάθμης (σχήμα 11)  
πρέπει να βρίσκεται μεταξύ των  
σημαδιών min και max.

### 6.1.2 Αλλαγή λαδιού



#### ΠΡΟΣΟΧΗ

Η πρώτη αλλαγή πρέπει να γίνει  
μετά από 25 ώρες λειτουργίας.  
Ολες οι επόμενες αλλαγές υγρού  
πρέπει να γίνονται κάθε 300 ώρες  
λειτουργίας ή μία φορά το χρόνο  
(ανάλογα με το πιο εκ των δύο θα  
συμβεί πρώτο).

**ΠΡΟΣΟΧΗ**

Τα παλιά λιπαντικά πρέπει να διατίθενται ως ειδικά απορρίμματα που ρυπαίνουν το περιβάλλον: κατά συνέπεια πρέπει να παραδίδονται σε κέντρα διαφοροποιημένης συλλογής.

**6.1.3 Αποστράγγιση του υγρού της ρεβέρσας**

Βγάλτε την τάπα (1 Εικ. 12) και αφήστε να τρέξει το λάδι από το ειδικό άνοιγμα στο κάτω μέρος του κιβωτίου.

**6.1.4 Γέμισμα της ρεβέρσας με υδραυλικό υγρό.**

Γεμίστε με λάδι για αυτόματα σα-σμάν ATF χρησιμοποιώντας τις ενδεδειγμένες ποσότητες. Προσθέστε την ποσότητα που θεωρείτε αναγκαία για την πλήρωση του εναλλάκτη θερμότητας και των σχετικών σωλήνων σύνδεσης

ZF 4-1 M:	0,42 λίτρα
ZF 5 M:	0,42 λίτρα
ZF 6 M:	0,42 λίτρα
ZF 10 M:	0,42 λίτρα
ZF 12 M:	0,60 λίτρα
ZF 15 M:	0,60 λίτρα
ZF 15 MA:	0,56 λίτρα
ZF 15 MIV:	1,00 λίτρα
ZF 25 M:	0,75 λίτρα
ZF 30 M:	min. 0,90 - max. 1,10 λίτρα

• Ισχύει για κλίσεις του άξονα μικρότερες των 20° (15° για ZF MIV).

Χρησιμοποιείτε μόνο λάδι για αυτόματα σασμάν σύμφωνα με τις προδιαγραφές της "Λίστας συνιστώμενων λαδιών" στη σελ.82

**6.1.5 Δοκιμαστική Διαδρομή**

- 1) Κάντε μία δοκιμαστική λειτουργία μετά την αλλαγή του λαδιού.
- 2) Τοποθετήστε τον μοχλό αλλαγής ταχυτήτων στην θέση Νεκρού Σημείου (N). Βάλτε μπροστά την μηχανή και αφήστε την να λειτουργεί στο ρελαντί για σύντομο χρονικό διάστημα έτσι

ώστε να γεμίσει το ψυγείο και οι σωλήνες με το λάδι ρεβέρσας.

- 3) Σταματήστε την μηχανή και ελέγξτε ξανά την στάθμη του λαδιού. Εάν χρειαστεί, συμπληρώστε λάδι. Πρέπει να αφαιρέσετε την όποια περίσσεια ποσότητα λαδιού.

Η στάθμη του υδραυλικού λαδιού στον δείκτη ελέγχου στάθμης (σχήμα 14, εξάρτημα I) πρέπει να βρίσκεται μεταξύ των σημαδιών min και max.

Η στάθμη του υδραυλικού λαδιού πρέπει να ελεγχθεί ξανά μετά από σύντομο χρονικό διάστημα λειτουργίας.

**6.1.6 Απόσυρση από τη λειτουργία για ορισμένο χρονικό διάστημα**

Εάν πρόκειται να αποσύρετε την ρεβέρσα για μεγάλο χρονικό διάστημα, για παράδειγμα, θέση εκτός λειτουργίας κατά την διάρκεια του χειμώνα, θα πρέπει να γεμίζετε την ρεβέρσα με το λάδι αυτομάτου ρεβέρσας (ATF) για να μην προκληθεί διάβρωση της ρεβέρσας.

**ΠΡΟΣΟΧΗ**

Να αλλάξετε το υδραυλικό λάδι όταν πρόκειται να θέσετε σε λειτουργία ξανά την ρεβέρσα.

**7.1 Αναζήτηση βλαβών**

Πρώτα από όλα να ελέγξετε εάν έχουν γίνει όλα σύμφωνα με τις οδηγίες λειτουργίας.

Σύμπτωμα	Πιθανή αιτία	Αποκατάσταση
1. Υψηλή θερμοκρασία υδραυλικού υγρού.	Η στάθμη του υγρού ανεβαίνει κατά την διάρκεια της λειτουργίας. Η στάθμη του υδραυλικού λαδιού είναι χαμηλή. Βούλωμα ή περιορισμός του ψυγείου υδραυλικού λαδιού. Δεν υπάρχει νερό στο σύστημα του ψυγείου. άγνωστη αιτία	Αδειάστε με την αντλία υδραυλικό λάδι μέχρι την θέση max στο δείκτη ελέγχου στάθμης. Συμπλήρωση υδραυλικού λαδιού. Αντικατάσταση ψυγείου και ξέπλυμα του δικτύου νερού. Έλεγχος του συστήματος ψύξης και επισκευή Συμβουλευτείτε εξουσιοδοτημένο συνεργείο
2. Παρουσία υγρού στο κέλυφος της ρεβέρσας	Λασκάρισμα βιδών Λασκάρισμα κοχλιωτών συνδέσεων Λασκάρισμα του δείκτη ελέγχου στάθμης. Υψηλή στάθμη λαδιού κατά τη λειτουργία	Σφίξιμο σύμφωνα με τις προδιαγραφές. Σφίξιμο, αντικατάσταση Σφίξιμο, αντικατάσταση Αδειάστε λάδι μέχρι το σημάδι MAX
3. Γίνεται δύσκολο η αλλαγή ταχυτήτων	Μοχλός επιλογής ταχυτήτων  Συνδεσμολογία	Συμβουλευτείτε ένα εξουσιοδοτημένο κατάστημα  Ρύθμιση
4. Η σύμπλεξη αργεί να γίνει	Μοχλός επιλογής ταχυτήτων  Συνδεσμολογία	Συμβουλευτείτε ένα εξουσιοδοτημένο κατάστημα  Ρύθμιση
5. Δεν κινείται το σκάφος	Μοχλό επιλογής Ακατάλληλη θέση επιλογέα Έχει χαθεί η προπέλα Σπάσιμο ελικοφόρου άξονα Δυσλειτουργία της ρεβέρσας Δυσλειτουργία μηχανής	Συμβουλευτείτε εξουσιοδοτημένο συνεργείο Ρύθμιση Αντικατάσταση Συμβουλευτείτε εξουσιοδοτημένο συνεργείο Συμβουλευτείτε εξουσιοδοτημένο συνεργείο Συμβουλευτείτε εξουσιοδοτημένο συνεργείο



## 8.1 Τεχνικά δεδομένα

### Technical Data for Pleasure Craft Duty

Based on engine power B to DIN 6270; shock factor

**K = 1.25 to be applied, if engine has 1 cylinder / K = 1.20 for 2 cylinders / K = 1.15 for 3 cylinders**

MODEL	RATIO		POWER / RPM		INPUT POWER CAPACITY						MAX RPM	WEIGHT		BELL HSGS. AND NOTES
	«A» Pos	«B»Pos	kW	hp	2800 rpm		3000 rpm		3600 rpm			kg	lb	
					kW	hp	kW	hp	kW	hp				
ZF 5 M	2.045	1.864	0.0066	0.0088	18	25	20	27	20	27	5000	8.5	19	SAE 6, B/W Max input power 20 kW
	2.722	2.150	0.0047	0.0063	13	18	14	19	17	23				

**K = 1.25 to be applied, if engine has 1 cylinder / K = 1.20 for 2 cylinders / K = 1.15 for 3 cylinders**

MODEL	RATIO		POWER / RPM		INPUT POWER CAPACITY						MAX RPM	WEIGHT		BELL HSGS. AND NOTES
	«A» Pos	«B»Pos	kW	hp	2800 rpm		3000 rpm		3600 rpm			kg	lb	
					kW	hp	kW	hp	kW	hp				
ZF 6 M	2.045	1.864	0.0066	0.0088	18	25	20	27	20	27	5000	10.3	23	SAE 4, 5, 6, B/W Max input power 20 kW
	2.722	2.150	0.0047	0.0063	13	18	14	19	17	23				

**K = 1.25 to be applied, if engine has 1 cylinder / K = 1.20 for 2 cylinders / K = 1.15 for 3 cylinders**

\*\* Max. 95 Nm (70 ft lb) admissible for main travelling direction with gear lever set to «B»

MODEL	RATIO		POWER / RPM		INPUT POWER CAPACITY						MAX RPM	WEIGHT		BELL HSGS. AND NOTES
	«A» Pos	«B»Pos	kW	hp	2800 rpm		3000 rpm		3600 rpm			kg	lb	
					kW	hp	kW	hp	kW	hp				
ZF 10 M	1.482	1.864	0.0109	0.0146	30	41	33	44	38	51	5000	10.3	23	SAE 4, 5, 6, B/W Max input power 38 kW. <b>Ratio 1.482 «B» Pos.</b> <b>max torque 95 Nm. Ratio</b> <b>1.792 «B» Pos. max</b> <b>torque 95 Nm.</b>
	1.792	1.864												
	2.045	1.864	0.0095	0.0128	27	36	29	38	34	46				
	2.722	2.150	0.0068	0.0091	19	26	20	27	25	33				

**K = 1.25 to be applied, if engine has 1 cylinder / K = 1.20 for 2 cylinders / K = 1.15 for 3 cylinders**

MODEL	RATIO		POWER / RPM		INPUT POWER CAPACITY						MAX RPM	WEIGHT		BELL HSGS. AND NOTES
	«A» Pos	«B»Pos	kW	hp	2800 rpm		3000 rpm		3600 rpm			kg	lb	
					kW	hp	kW	hp	kW	hp				
ZF 12 M	2.136	1.955	0.0131	0.0176	37	49	39	53	47	63	5000	13	29	SAE 4, 5, 6, B/W, Yanmar JH Max input power 55 kW
	2.632	1.955	0.0111	0.0149	31	42	33	45	40	54				

**K = 1.25 to be applied, if engine has 1 cylinder / K = 1.20 for 2 cylinders / K = 1.15 for 3 cylinders**

\*\* Max. 120 Nm (88.5 ft lb) admissible for main travelling direction with gear lever set to «B»

MODEL	RATIO		POWER / RPM		INPUT POWER CAPACITY						MAX RPM	WEIGHT		BELL HSGS. AND NOTES
	«A» Pos	«B»Pos	kW	hp	3000 rpm		3600 rpm		3800 rpm			kg	lb	
					kW	hp	kW	hp	kW	hp				
ZF 15 M	1.556	1.955	0.0152	0.0204	46	61	55	73	55	74	5000	13	29	SAE 4, 5, 6, B/W, Yanmar JH Max input power 55 kW. <b>Ratio 1.556 «B» Pos.</b> <b>max torque 120 Nm.</b> <b>Ratio 1.875 «B» Pos.</b> <b>max torque 120 Nm.</b>
	1.875	1.955												

«A» POS = continuous running position (normally AHEAD).

«B» POS = reverse position.

B/W = Borg Warner adaptor.

Note = For all «M» (Mechanical) transmissions reduce power capacity by the following shock factors: 1 cylinder engine ÷ 1.25, 2 cylinder engine ÷ 1.20, 3 cylinder engine ÷ 1.15.





**K = 1.25 to be applied, if engine has 1 cylinder / K = 1.20 for 2 cylinders / K = 1.15 for 3 cylinders**

\*\* Max. 120 Nm (88.5 ft lb) admissible for main travelling direction with gear lever set to «B»

MODEL	RATIO		POWER / RPM		INPUT POWER CAPACITY						MAX RPM	WEIGHT		BELL HSGS. AND NOTES	
	«A» Pos	«B»Pos	kW	hp	3000 rpm		3600 rpm		3800 rpm			kg	lb		
					kW	hp	kW	hp	kW	hp					
ZF 15 MA 8 degrees	1.875	1.955	0.0152	0.0204	46	61	55	73	55	74	5000	13.5	30	SAE 4, 5, 6, B/W, Yanmar JH Max input power 55 kW. <b>Ratio 1.875 «B» Pos. max torque 120 Nm. Ratio 2.136 «B» Pos. max torque 120 Nm.</b>	
	2.136	1.955	0.0131	0.0176	39	53	47	63	50	67					5000
	2.632	1.955	0.0111	0.0149	33	45	40	54	42	57					5000

**K = 1.25 to be applied, if engine has 1 cylinder / K = 1.20 for 2 cylinders / K = 1.15 for 3 cylinders**

\* Max. 120 Nm (88.5 ft lb) admissible for main travelling direction with gear lever set to «B».

\*\* Max 45 kW for main travelling direction with gear lever set to «B».

MODEL	RATIO		POWER / RPM		INPUT POWER CAPACITY						MAX RPM	WEIGHT		BELL HSGS. AND NOTES	
	«A» Pos	«B»Pos	kW	hp	3000 rpm		3600 rpm		3800 rpm			kg	lb		
					kW	hp	kW	hp	kW	hp					
ZF 15 MIV 8 degrees	2.134	2.224	0.0152	0.0204	46	61	55	73	55	74	5000	21	47	SAE 4, 5, B/W, Yanmar JH Max input power 55 kW. <b>Ratio 2.134 «B» Pos. max torque 120 Nm.</b>	
	2.718	2.224	0.0111	0.0149	33	45	40	54	42	57					5000
	2.995	2.224													

**K = 1.25 to be applied, if engine has 1 cylinder - K = 1.20 for 2 cylinders - K = 1.15 for 3 cylinders**

\*\* Max. 230 Nm (170 ft lb) admissible for main travelling direction with gear lever set to «B»

MODEL	RATIO		POWER / RPM		INPUT POWER CAPACITY						MAX RPM	WEIGHT		BELL HSGS. AND NOTES	
	«A» Pos	«B»Pos	kW	hp	3000 rpm		3600 rpm		3800 rpm			kg	lb		
					kW	hp	kW	hp	kW	hp					
ZF 25 M	1.880	2.095	0.0262	0.0351	79	105	80	107	80	107	5000	18.5	41	SAE 4, 5, B/W, Yanmar JH Max input power 80 kW. <b>Ratio 1.880 «B» Pos. max torque 230 Nm.</b>	
	2.273	2.095	0.0216	0.0289	65	87	78	104	80	107					5000
	2.737	2.722	0.0177	0.0237	53	71	64	85	67	90					5000

**K = 1.25 to be applied, if engine has 1 cylinder / K = 1.20 for 2 cylinders / K = 1.15 for 3 cylinders**

\*\* Max. 169 Nm (125 ft lb) admissible for main travelling direction with gear lever set to «B»

MODEL	RATIO		POWER / RPM		INPUT POWER CAPACITY						MAX RPM	WEIGHT		BELL HSGS. AND NOTES
	«A» Pos	«B»Pos	kW	hp	3000 rpm		3600 rpm		3800 rpm			kg	lb	
					kW	hp	kW	hp	kW	hp				
ZF 25 MA 8 degrees	2.227	2.737	0.0215	0.0288	64	86	77	104	80	107	5000	21.1	47	SAE 4, 5, B/W, Yanmar JH Max input power 80 kW. <b>Ratio 2.227 «B» Pos. max torque 169 Nm.</b>
	2.737	2.737	0.0177	0.0237	53	71	64	85	67	90				

**K = 1.25 to be applied, if engine has 1 cylinder / K = 1.20 for 2 cylinders / K = 1.15 for 3 cylinders**

\*\* Max. 185 Nm (137 ft lb) admissible for main travelling direction with gear lever set to «B»

MODEL	RATIO		POWER / RPM		INPUT POWER CAPACITY						MAX RPM	WEIGHT		BELL HSGS. AND NOTES
	«A» Pos	«B»Pos	kW	hp	3000 rpm		3600 rpm		3800 rpm			kg	lb	
					kW	hp	kW	hp	kW	hp				
ZF 30 M	2.148	2.636	0.0241	0.0323	72	97	87	116	92	123	5000	23	51	4 & 5 Yanmar JH Max input power 95 kW. <b>Ratio 2.148 «B» Pos. max torque 185 Nm. Ratio 2.696 «B» Pos. max torque 185 Nm.</b>
	2.696	2.636												

«A» POS = continuous running position (normally AHEAD).

«B» POS = reverse position.

B/W = Borg Warner adaptor.

Note = For all «M» (Mechanical) transmissions reduce power capacity by the following shock factors: 1 cylinder engine ÷ 1.25, 2 cylinder engine ÷ 1.20, 3 cylinder engine ÷ 1.15.



## 9.1 Εγγύηση

### 9.1.1 Βασική Εγγύηση

Η ZF Marine Arco S.p.A. εγγυάται τη ρεβέρσα τύπου ZFM ότι είναι απαλλαγμένη ελαττωμάτων σε ότι αφορά την ποιότητα εργασίας και τα υλικά υπό συνθήκες κανονικής λειτουργίας και συντήρησης, υπό την προϋπόθεση ότι η εγγύηση αυτή θα ισχύει αν, και μόνον εάν, έχει εγκατασταθεί και λειτουργεί ο εξοπλισμός σύμφωνα με τον προβλεπόμενο από το κατασκευαστή τρόπο.

Η υποχρέωση της ZF Marine Arco S.p.A. βάσει της παρούσας εγγύησης, θα περιορίζεται στην αντικατάσταση ή την επισκευή, κατά τη διακριτική ευχέρεια της, οποιουδήποτε τμήματος ή τμημάτων που διαπιστωθεί από την ZF Marine Arco S.p.A. ότι είναι ελαττωματικά, μετά από εξέταση των ανωτέρω, υπό την προϋπόθεση ότι το τμήμα ή τα τμήματα θα επιστραφούν στο πλησιέστερο εξουσιοδοτημένο κατάστημα της ZF Marine Arco S.p.A., με προπληρωμένο το ναύλο, εντός χρονικού διαστήματος:

Είκοσι τεσσάρων (24) μηνών από την ημερομηνία παράδοσης σε πλήρη λειτουργία ή τριάντα έξι (36) μηνών από την ημερομηνία παράδοσης στον κατασκευαστή της μηχανής, οποιουδήποτε εκ των δύο συμβεί πρώτα.

Οι υποχρεώσεις της ZF Marine Arco S.p.A. βάσει της παρούσας εγγύησης, όπως αναφέρονται εις το παρόν θα υπόκεινται, επίσης, σε συμμόρφωση εκ μέρους του διανομέα ή του κατασκευαστή της μηχανής ο οποίος έχει προμηθευτεί το προϊόν με τις διαδικασίες περί της εγγυήσεως, οι οποίες αποτελούν αναπόσπαστο τμήμα της παρούσας εγγύησης.

Όλες οι εγγυήσεις θα παραδίδονται στους διανομείς και τους κατασκευαστές της μηχανής οι οποίοι αγόρασαν την ναυτική ρεβέρσα τύπου ZF.

Η παρούσα εγγύηση δεν θα ισχύει για οποιοδήποτε τμήμα ή τμήματα τα οποία έχουν επισκευαστεί ή υποστεί μετατροπή, χωρίς την προηγούμενη σύμφωνη γνώμη του

επίσημου αντιπροσώπου της ZF Marine Arco S.p.A.

Η παρούσα εγγύηση δεν θα ισχύει εάν το προϊόν ή οποιοδήποτε από τα παρελκόμενά του ή εξαρτήματά αυτού έχουν χρησιμοποιηθεί καταχρηστικώς, ή δεν έχουν τύχει της προβλεπόμενης φροντίδας και συντήρησης ή έχουν υποστεί βλάβη εξ' ατυχήματος, ή η λειτουργία τους δεν έχει γίνει σύμφωνα με τις τυπωμένες οδηγίες της ZF Marine Arco S.p.A. ή έχουν λειτουργήσει υπό συνθήκες πιο αντίξοες από τις προβλεπόμενες, ή συνθήκες που υπερβαίνουν εκείνες οι οποίες ορίζονται στις προδιαγραφές για το εν λόγω προϊόν, ή έχουν εγκατασταθεί ή ξανα-εγκατασταθεί λαθεμένα ή δεν έχει γίνει σωστά η συντήρηση και η λειτουργία αυτών.

Η παρούσα εγγύηση αντικαθιστά ρητώς όλες τις άλλες εγγυήσεις, ρητές ή συμπερασματικές, περιλαμβανομένων και των εγγυήσεων εμπορευσιμότητας και καταλληλότητας για χρήση, υποκαθιστά δε όλες τις άλλες υποχρεώσεις που περιλαμβάνουν απεριορίστως τις αποθετικές ζημιές και η ZF Marine Arco S.p.A. δεν αναλαμβάνει καμία υποχρέωση ούτε εξουσιοδοτεί κανένα άτομο να αναλάβει για λογαριασμό της ZF Marine Arco S.p.A. οποιαδήποτε άλλη υποχρέωση σχετικά με την πώληση ρεβερσών τύπου ZFM Reversing marine transmission.

Η ZF Marine Arco S.p.A. δεν θα είναι υπεύθυνη σε καμία περίπτωση για οποιαδήποτε παραβίαση της εγγύησης σε οποιοδήποτε μέτρο που υπερβαίνει το τίμημα αγοράς της ρεβέρσας τύπου ZFM Reversing marine transmission.

### 9.1.2 Υπευθυνότητα Στρέψης και Στρεπτικοί Σύνδεσμοι

Ο συναρμολογητής του συστήματος μετάδοσης κίνησης και του κινούμενου εξοπλισμού έχει την ευθύνη της διασφάλισης της στρεπτικής συμβατότητας.

Η ZF Marine Arco S.p.A. δεν αποδέχεται τυχόν ευθύνη για θόρυβο του κιβωτίου ταχυτήτων που προκα-

λείται λόγω κραδασμών ή για βλάβη του κιβωτίου ταχυτήτων, του εύκαμπτου συνδέσμου ή άλλων μερών της διάταξης μετάδοσης κίνησης, η οποία ήθελε προκληθεί από τέτοιου είδους κραδασμούς. Για περαιτέρω πληροφορίες και υποστήριξη επικοινωνήστε με τη ZF Marine Arco S.p.A.

Η ZF Marine Arco S.p.A. συνιστά τη χρήση αναστολέα ορίου στρέψης για σκάφη με έναν κινητήρα, όπου η απώλεια προωστικής ισχύος μπορεί να προκαλέσει απώλεια του ελέγχου. Ο αγοραστής έχει την ευθύνη για την παραγγελία αυτής της προαιρετικής διάταξης, η οποία μπορεί να επιφέρει πρόσθετη δαπάνη και πιθανόν μία αύξηση του μήκους εγκατάστασης. Η ZF Marine Arco S.p.A. δεν αποδέχεται ευθύνη για τυχόν ατομικό τραυματισμό, θανατηφόρο ατύχημα ή υλικές ζημιές λόγω αμέλειας του αγοραστή να φροντίσει για την τοποθέτηση αναστολέα ορίου στρέψης.

Η ZF Marine Arco S.p.A. επιλέγει στρεπτικούς συνδέσμους βάσει των τιμών της ονομαστικής ροπής εισόδου και των κοινά αποδεκτών σταθερών στροφών του κινητήρα. Επικοινωνήστε με τη ZF Marine Arco S.p.A. για λεπτομέρειες όσον αφορά τα όρια στροφών των κανονικά διατιθέμενων στρεπτικών συνδέσμων, τα οποία ενδέχεται να είναι κατώτερα του ορίου της μετάδοσης.

Ενδέχεται να απαιτούνται ειδικό στρεπτικοί σύνδεσμοι για την κάλυψη των απαιτήσεων πιστοποίησης ηνογνωμόνων (Survey Society Ice).

# Hrvatski

## Sadržaj

1.1	Uvod.....	75
2.1	Prepoznavanje brodskog prijenosa.....	75
3.1	Opis.....	75
4.1	Instaliranje.....	75
5.1	Rad.....	76
6.1	Održavanje.....	77
7.1	Traženje kvarova.....	78
8.1	Tehnički podaci.....	79
9.1	Jamstvo.....	81
10.1	Popis preporučenih ulja.....	82
11.1	Popis ovlaštenih servisa.....	83
12.1	Montažni nacrti.....	84
13.1	Warranty Card.....	95

## 1.1 Uvod

### 1.1.1 OBVEZE KUPCA

Kupac je odgovoran za obavljanje provjera iz ovoga priručnika kako bi podmazivanje, hlađenje i održavanje brodskog prijenosa bili u skladu sa zahtjevima i rad ostao unutar sigurnosnih granica.

Svaki se brodski prijenos isporučuje s jamstvom, koje vrijedi ukoliko se dosljedno provode upute iz ovoga priručnika.



#### PAŽNJA

**Proizvođač nije odgovoran za bilo kakav kvar ili oštećenje prouzrokovano pogrešnom montažom, pogrešnim korištenjem opreme i nedovoljnim održavanjem. Kupac se prije montaže treba uvjeriti da ne postoje nikakve vanjske sile, primjerice torzijske vibracije prouzrokovane radijalnim ili aksijalnim savijanjem.**

**Spojevi motora, osovine i propelera mogu proizvesti torzijske vibracije uzrokujući udarnu buku u zupčanicima s mogućnošću oštećenja motora i/ili brodskog prijenosa. Proizvođač nije odgovoran za torzijske vibracije koje nastaju zbog montaže.**

Ovaj priručnik ima tri glavna poglavlja:

### 1.1.2 OPIS

Poglavlje ukratko opisuje rad, korištenje i dijelove brodskog prijenosa ZFM.

### 1.1.3 KORIŠTENJE

Poglavlje opisuje postupke korištenja i sve potrebne mjere sigurnosti.

### 1.1.4 ODRŽAVANJE

Poglavlje sadrži sve upute potrebne za održavanje i servisiranje kojih se kupac mora pridržavati.

Pojmovi „lijevo, desno, lijevi bok i desni bok“ koji se rabe u ovom priručniku uvijek se odnose na brodске prijenose montirane u pravcu kretanja prema naprijed.

Važne informacije koje se odnose na tehničku ispravnost i na sigurnost korištenja istaknute su na sljedeći način:



#### OPASNOST

**Svi postupci, radnje, uvjeti, preporuke, i sl. koji, ukoliko ih se korisnik izričito ne pridržava, mogu uzrokovati štetu ili smrt korisnika.**



#### PAŽNJA

**Svi postupci, radnje, uvjeti, preporuke, i sl. koji, ukoliko ih se korisnik izričito ne pridržava mogu prouzročiti štetu ili uništenje opreme.**

**Napomena** Odnose se na tehničke postupke kojima korisnik opreme mora posvetiti osobitu pažnju.

**OPASNOST, PAŽNJA i Napomena** uvijek se nalaze ispred teksta na koji se odnose.

## 2.1 Prepoznavanje brodskog prijenosa

Identifikaciona tablica je postavljena na izmjenjivaču.

Sl. 1 pokazuje jedan primjer identifikacione tablice:

- A** Serijski broj brodskog prijenosa.
- B** Kod prijenosa.
- C** Odnos prijenosa za propeler koji se vrti u istom smjeru kao motor.
- D** Odnos prijenosa za propeler koji se vrti u suprotnom smjeru od motora.
- E** Svake se godine pridjeljuje novo (sljedeće) slovo.
- F** Tip brodskog prijenosa.

Značenje simbola brodskog prijenosa

- G** Tip brodskog prijenosa.
- H** Veličina brodskog prijenosa
- I** Verzija brodskog prijenosa

## 3.1 Opis

ZFM brodski prijenosi su uređaji s helikoidalnim zupčanicima upravljani automatskim sklopom. Ističu se zbog robusnosti i pouzdanosti. Posebno preporučujemo pažljivo pridržavanje ovih uputa za montažu, uporabu i održavanje.

Nepridržavanje uputa iz ovog priručnika ili bilo kakva neovlaštena prepravka na invertoru prouzrokuje gubitak jamstva.

Na zahtjev proizvođač isporučuje uputstvo za popravak.

Sl 2:

- 1) Izmjenjivač
- 2) Izlazna prirubnica
- 3) Identifikacijska tablica
- 4) Poluga za pokretanje.
- 5) pritezač daljinskog upravljača.
- 6) Zvono.
- 7) Ulazna osovina
- 8) Mjerna šipka ulja

## 4.1 Instaliranje

Za montažu brodskom prijenosa ZFM potrebno je postupiti prema sljedećim uputama:

- Montažu mogu izvesti samo specijalizirano osoblje.
- **Kosi položaj:** (Sl. 3):  
Pozicija prijenosa, u odnosu na ulaznu osovinu, ne smije biti više od kuta 20° (15° za ZF MIV), u neprestanom pogonu.  
Za kut bočnog nagiba obratiti se proizvođaču.
- **Elastični zglobovi:** Između motora i brodskog prijenosa potrebno je postaviti elastični vezni zglobovi s minimalnim radijalnim hodom (0,5mm); između brodskog prijenosa i osovine propelera preporučuje se veza pomoću elastičnog zgloba.
- **Uparivanje motora i prijenosa** (Sl.4):
  - 1) Prirubnica motora
  - 2) Zamašnjak
  - 3) Elastični spoj
  - 4) Osovina brodskog prijenosa
  - 5) Prirubnica brodskog prijenosa
  - 6) Prirubnica zamašnjaka

Maksimalne dozvoljene radijalne i aksijalne vrijednosti X: B-0,1 mm.

• **Uparivanje prijenosa i osovine propelera:** (Sl. 5 - 6):

• Ispravno upariti prijenos i motor.

Više pojedinosti navedeno je u uputama za montažu.

**Vrsta ulja:** ATF (ulje za automatske mjenjače) vidi pogl. 10.1.

## 5.1 Rad

Prije isporuke svi uređaji podvrgnuti su pokusnom radu.

U normalnim uvjetima rada promjena smjera kretanja dozvoljena je samo pri najmanjem broju okretaja motora. U slučaju nužde ipak je dozvoljena promjena smjera kretanja pri višim brojem okretaja.

Ispravno djelovanje vodenog kruga je zajamčeno samo u slučaju da se redovito mijenja hidraulično ulje, kao što je i predviđeno kod programiranog održavanja (Vidi poglavlje 6.1).

Povremeno vizualno provjerite da ne postoje gubici ulja.



### OPASNOST

**Pristupiti radovima na brodskom prijenosu samo kad su motor i propeler zaustavljeni.**



### PAŽNJA

**Prije prvog pokretanja u prijenos se mora naliti predviđeno hidrauličko ulje.**

**Za postupke punjenja, za tip i količinu i razinu tekućine, vidi poglavlje 6.1.4**



### PAŽNJA

**Korištenje broskog prijenosa s nedovoljnom količinom tekućine oštećuje zupčanike.**

**Prevelika količina ulja može prouzrokovati gubitke na brtvi i na ispustu te može znatno povećati radnu temperaturu.**

### 5.1.1 STAVLJANJE U RAD



### PAŽNJA

**Prije stavljanja broskog prijenosa u rad provjeriti razinu ulja (vidi poglavlje 6.1.1).**



### PAŽNJA

**U normalnim radnim uvjetima položaj upravljačke poluge za promjenu smjera kretanja mora se promijeniti pri radu motora na minimumu.**

**Promjene pri višim brojem okretaja mogu preopteretiti diskove kvačila, a to treba izbjegavati prilikom normalnog rada.**

**Napomena** U slučaju nužde, smjer kretanja (naprijed – natrag) može se promijeniti i pri velikim brzinama motora.

### RADNI POLOŽAJI (slika 7):

A = Smjer okretanja propelera obrnut od smjera okretanja motora

N = Položaj praznog hoda

B = Smjer okretanja propelera isti kao smjer okretanja motora



### OPASNOST

**Motor pokrenuti samo kad je upravljačka poluga u položaju praznoga hoda.**

Radna temperatura ulja prijenosa mora biti između 50°C (122°F) i 80°C (176°F). Maksimalna temperatura ATF ulja od 100°C (212°F) dozvoljena je samo tijekom kratkog vremenskog razdoblja.



### PAŽNJA

**Ukoliko je temperatura previsoka, odmah zaustavite motor, provjerite razinu tekućine u brodskom prijenosu i ispravnost rada izmjenjivača topline. Ne stavljajte plovilo u pokret ukoliko nije otklonjen uzrok neispravnosti rada.**

### 5.1.2 PLOVIDBA NA JEDRA TEGLJENJE ILI USIDRENJE

Kada je motor isključen i plovilo ide na jedra, u slučaju da je tegljeno ili je usidreno, propeler se može vrtjeti radi strujanja vode.

Ova pojava ne oštećuje prijenos. U plovilu s dva motora, kad je samo jedan motor u radu, propeler isključenog motora može se slobodno okretati.

Kad je motor isključen, položaj upravljačke poluge je nebitan.



### PAŽNJA

**Kad je osovina propelera u slobodnom položaju, upravljačka poluga mora biti u položaju "N", (Sl.7).**

**U slučaju potrebe za blokiranjem osovine propelera koristiti položaj suprotan od smjera kretanja plovila, inače se oštećuje prijenosni sklop.**



### OPASNOST

**Ne poduzimajte nikakve zahvate na prijenosu tijekom tegljenja plovila ili kad je plovilo usidreno u rijeci, jer se propeler može okretati.**



### OPASNOST

**Ne poduzimajte nikakve zahvate na prijenosu kod dvojne instalacije kad je jedan od dvaju motora u radu. Propeler zaustavljenog motora se može okretati.**



### OPASNOST

**Kad je motor uključen na minimumu, a propeler treba mirovati (primjerice kad je potrebno napuniti akumulator), upravljačka poluga mora biti u neutralnom položaju N (sl. 7).**

**Izbjegavati okretanje hidrauličkog broskog prijenosa u neutralni položaj pri visokom broju okretaja tijekom duljeg vremena.**

### 5.1.3 SISTEM ZA UPRAVLJANJE



### PAŽNJA

**Provjeriti da li se upravljačka sajla može slobodno pomicati.**

Korisni hod:

ZF = 5 M - 6 M - 10 M - 12 M - 15 M  
- 15 MA - 15 MIV - 25 M - 25 MA  
- 30 M.

Minimalni korisni hod (N-A=N-B) upravljačke poluge, mjereno na vanjskom otvoru za priključak, mora biti barem 35mm; ako se mjeri iz unutarnjeg otvora mora biti barem 30 mm.



**Sl. 8:**

- 1) Vijak za pričvršćivanje, stezni moment  $22 \pm 1$  Nm.
- 2) Minimalni hod za upravljačku sajlu
- 3) Ne skidati poklopac
- 4) Čep ispusta ulja  
Stezni moment:  $Ma = 22$  Nm (16 lb-ft).

**Korisni hod:****ZF 4-1 M**

Minimalni korisni hod (N-A=N-B) dupravljačke poluge, mjereno na vanjskom otvoru za priključak, mora biti  $38,5 \pm 1,5$  mm; ako se mjeri iz unutarnjeg otvora mora biti barem 33,5 mm. Iz položaja praznog hoda, kad poluga rotira za  $10^\circ$ - $12^\circ$ , ona se počinje kretati i u okomitom smjeru prema naprijed i zaustavlja se na kraju hoda (kut od  $40^\circ$ ).

**Sl. 9:**

- 1) Vijak za pričvršćivanje, stezni moment  $22 \pm 1$  Nm.
- 2) Ne otpustiti maticu
- 3) Ne skidati poklopac

**Položaj poluge:** U položaju praznog hoda mora biti okomita na upravljačku sajlu.

Poluga se može okretati te pričvrstiti u bilo kojem položaju pomoću steznog vijka.

Poluga mora udaljena od poklopca barem za 0,5mm.

Demontaža ili samo otpuštanje vijaka poklopca zahtijevaju novo podešavanje (koje mora obaviti ovlašteno osoblje).

**Sl.10:**

- 1) Mjerna šipka i čep za otvor za dopunu ulja 17mm  
Stezni moment:  $Ma = 20$  Nm (15 lb-ft).
- 2) Udaljenost upravljačke poluge od poklopca min. 0,5mm

**KONTROLE:** u svrhu osiguranja pravilnog djelovanja, potrebno je redovito kontrolirati položaj poluge.

**6.1 Održavanje****6.1.1 PROVJERA RAZINE ULJA****OPASNOST**

**Ne poduzimajte nikakve zahvate na prijenosu tijekom tegljenja plovila ili kad je plovilo usidreno u rijeci, jer se propeler može okretati.**

**OPIS MJERNE ŠIPKE ULJA (Sl. 11):**

- 1) Površina kućišta
- 2) Razina ulja
- 3) Mjerna šipka
- 4) Ulje ATF
- 5) Podmetak za držanje.

Provjera ulja je moguća na hladno ili na vruće.

**NAPOMENA:** Prije stavljanja u rad izmjenjivača, uvijek kontrolirati nivo ulja, djelujući na sljedeći način.

- Otpustiti mjernu šipku ulja (sl. 11) ručno je okrećući u smjeru suprotnom od kazaljke na satu, zatim je izvući.
- Šipku očistiti čistom krpom bez prašine.
- Vratiti šipku u otvor bez zavrtnja ; izvaditi šipku i provjeriti da li je razina ulja unutar granica maksimuma i minimuma (3-4 sl. 11).
- Vratiti šipku u otvor te je pričvrstiti okrećući je u smjeru kazaljke na satu.

**PAŽNJA**

**U trenutku isključenja motora ulje koje se nalazi u hidrauličkom krugu pretočit će se u prijenos; količina ovoga ulja ovisi o vrsti izmjenjivača i hidrauličkog kruga koji se koriste za hlađenje. Nakon određenog vremena ulje se taloži u brodskom prijenosu što uzrokuje podizanje razine ulja. Nemojte uklanjati višak ulja već postupite prema točkama.**

- Pustite da motor radi na minimumu s brodskim prijenosom u položaju praznog hoda do punjenja uljem izmjenjivača topline i cijevi hidrauličkog kruga.

- Isključite motor i odmah provjerite razinu ulja; po potrebi nadolijte. Razina tekućine mora biti unutar oznaka maksimuma i minimuma koje se nalaze na šipki (sl. 11). Nakon kratkog vremena ponovite postupak.

**6.1.2 ZAMJENA ULJA****PAŽNJA**

**Prva zamjena ulja mora se obaviti nakon 25 sati rada. Sve sljedeće zamjene moraju se obaviti barem nakon 300 sati rada, a u svakom slučaju razdoblje zamjene ne smije biti dulje od jedne godine.**

**PAŽNJA**

**Istrošeno mazivo ulje treba obraditi kao poseban otpad štetan za okoliš; i treba ga stoga otpremiti shodno njegovom diferencijalnom sastavu.**

**6.1.3 ISPUŠTANJE ULJA**

Skinuti čep (1 Sl. 12) i pustiti da se ulje pretoči u namjensku rupu koja se nalazi u donjem dijelu kutije.

**6.1.4 PUNJENJE ATF ULJEM**

Napuniti ulje za automatske mjenjače ATF poštivajući količine u nastavku navedene.

Dodati količinu koja se smatra kao neophodna za punjenje razmjenjivača toplote i odgovarajućih cijevi za spajanje.

ZF 4-1 M: .....	0,42 l
ZF 5 M: .....	0,42 l
ZF 6 M: .....	0,42 l
ZF 10 M: .....	0,42 l
ZF 12 M: .....	0,60 l
ZF 15 M: .....	0,60 l
ZF 15 MA: .....	0,56 l
ZF 15 MIV: .....	1,00 l
ZF 25 M: .....	0,75 l
ZF 25 MA: .....	0,75 l
ZF 30 M: .....	min. 0,90 - max. 1,10 l

- Vrijedi za nagib donje osovine na kut od 20 stupnjeva ( $15^\circ$  per ZF MIV).

Koristiti isključivo ulje za automatske mjenjače kao u specifikacijama navedenim u "Spisku ulja koji se preporučavaju" na str. 82.

### 6.1.5 PROBNI RAD

- 1) Nakon zamjene ulja obaviti probni rad.
- 2) Upravljačku polugu postaviti u položaju praznog hoda (N). Pokrenuti motor i pustiti da kratko vrijeme radi na minimumu; izmjenjivač topline i hidraulički krug napunit će se uljem iz prijenosa.
- 3) Zaustaviti motor i ponovo provjeriti razinu ulja.

Po potrebi nadoliti. Višak ulja mora se ukloniti.

Razina ulja mora se nalaziti između oznaka MIN i MAX mjerne šipke. Razinu ulja potrebno je ponovno provjeriti nakon kratkog razdoblja rada.

### 6.1.6 KONZERVIRANJE

Ukoliko je potrebno prijenos uskladištiti za dulje razdoblje, primjerice tijekom zime, potrebno ga je u potpunosti napuniti ATF uljem (iz otvora mjerne šipke); to je potrebno zbog zaštite sklopa od korozije.



**PAŽNJA**

**Prilikom ponovnog stavljanja u rad prijenosa zamijeniti ulje.**

## 7.1 Traženje kvarova

Najprije provjeriti da li su provedeni svi postupci iz uputa opisanih u prijašnjim točkama.

Kvar	Mogući uzrok	Rješenje
<b>1. Visoka temperatura ulja</b>	<ul style="list-style-type: none"> <li>- Previsoka razina ulja</li> <li>- Niska razina ulja</li> <li>- Začepljen izmjenjivač topline</li> <li>- Nedostatak vode u krugu</li> </ul>	<ul style="list-style-type: none"> <li>- Otkloniti višak</li> <li>- Nadoliti</li> <li>- Zamijeniti izmjenjivač i provjeriti krug vode</li> <li>- Provjeriti krug i popraviti mjesto gubitka</li> </ul>
<b>2. Prisutstvo ulja na kućištu</b>	<ul style="list-style-type: none"> <li>- Otpušteni vijci</li> <li>- Otpušteni spojevi</li> <li>- Otpuštena mjerna šipka ulja</li> <li>- Previsoka razina ulja tijekom rada</li> </ul>	<ul style="list-style-type: none"> <li>- Stegnuti preporučenom silom</li> <li>- Stegnuti ili zamijeniti</li> <li>- Stegnuti ili zamijeniti</li> <li>- Otkloniti do oznake maksimuma</li> </ul>
<b>3. Teško uključivanje</b>	<ul style="list-style-type: none"> <li>- Blokirani razdjelnik</li> <li>- Daljinski upravljač</li> </ul>	<ul style="list-style-type: none"> <li>- Obratiti se ovlaštenom servisu</li> <li>- Podešavanje</li> </ul>
<b>4. Sporo uključivanje</b>	<ul style="list-style-type: none"> <li>- Blokirani razdjelnik</li> <li>- Daljinski upravljač</li> </ul>	<ul style="list-style-type: none"> <li>- Obratiti se ovlaštenom servisu</li> <li>- Podešavanje</li> </ul>
<b>5. Plovilo se ne pokreće</b>	<ul style="list-style-type: none"> <li>- Blokirani razdjelnik</li> <li>- Pogrešan položaj upravljačke poluge</li> <li>- Gubitak propelera</li> <li>- Lom osovine propelera</li> <li>- Kvar na prijenosu</li> <li>- Kvar na motoru</li> </ul>	<ul style="list-style-type: none"> <li>- Obratiti se ovlaštenom servisu</li> <li>- Podešavanje</li> <li>- Ponovno montirati</li> <li>- Obratiti se ovlaštenom servisu</li> <li>- Obratiti se ovlaštenom servisu</li> <li>- Obratiti se ovlaštenom servisu</li> </ul>



## 8.1 Tehnički podaci

### Technical Data for Pleasure Craft Duty

Based on engine power B to DIN 6270; shock factor

K = 1.25 to be applied, if engine has 1 cylinder / K = 1.20 for 2 cylinders / K = 1.15 for 3 cylinders

MODEL	RATIO		POWER / RPM		INPUT POWER CAPACITY						MAX RPM	WEIGHT		BELL HSGS. AND NOTES
	«A» Pos	«B»Pos	kW	hp	2800 rpm		3000 rpm		3600 rpm			kg	lb	
					kW	hp	kW	hp	kW	hp				
ZF 5 M	2.045	1.864	0.0066	0.0088	18	25	20	27	20	27	8.5	19	SAE 6, B/W Max input power 20 kW	
	2.722	2.150	0.0047	0.0063	13	18	14	19	17	23				5000

K = 1.25 to be applied, if engine has 1 cylinder / K = 1.20 for 2 cylinders / K = 1.15 for 3 cylinders

MODEL	RATIO		POWER / RPM		INPUT POWER CAPACITY						MAX RPM	WEIGHT		BELL HSGS. AND NOTES
	«A» Pos	«B»Pos	kW	hp	2800 rpm		3000 rpm		3600 rpm			kg	lb	
					kW	hp	kW	hp	kW	hp				
ZF 6 M	2.045	1.864	0.0066	0.0088	18	25	20	27	20	27	10.3	23	SAE 4, 5, 6, B/W Max input power 20 kW	
	2.722	2.150	0.0047	0.0063	13	18	14	19	17	23				5000

K = 1.25 to be applied, if engine has 1 cylinder / K = 1.20 for 2 cylinders / K = 1.15 for 3 cylinders

\*\* Max. 95 Nm (70 ft lb) admissible for main travelling direction with gear lever set to «B»

MODEL	RATIO		POWER / RPM		INPUT POWER CAPACITY						MAX RPM	WEIGHT		BELL HSGS. AND NOTES
	«A» Pos	«B»Pos	kW	hp	2800 rpm		3000 rpm		3600 rpm			kg	lb	
					kW	hp	kW	hp	kW	hp				
ZF 10 M	1.482	1.864	0.0109	0.0146	30	41	33	44	38	51	10.3	23	SAE 4, 5, 6, B/W Max input power 38 kW. Ratio 1.482 «B» Pos. max torque 95 Nm. Ratio 1.792 «B» Pos. max torque 95 Nm.	
	1.792	1.864												
	2.045	1.864	0.0095	0.0128	27	36	29	38	34	46				5000
	2.722	2.150	0.0068	0.0091	19	26	20	27	25	33				5000

K = 1.25 to be applied, if engine has 1 cylinder / K = 1.20 for 2 cylinders / K = 1.15 for 3 cylinders

MODEL	RATIO		POWER / RPM		INPUT POWER CAPACITY						MAX RPM	WEIGHT		BELL HSGS. AND NOTES
	«A» Pos	«B»Pos	kW	hp	2800 rpm		3000 rpm		3600 rpm			kg	lb	
					kW	hp	kW	hp	kW	hp				
ZF 12 M	2.136	1.955	0.0131	0.0176	37	49	39	53	47	63	13	29	SAE 4, 5, 6, B/W, Yanmar JH Max input power 55 kW	
	2.632	1.955	0.0111	0.0149	31	42	33	45	40	54				5000

K = 1.25 to be applied, if engine has 1 cylinder / K = 1.20 for 2 cylinders / K = 1.15 for 3 cylinders

\*\* Max. 120 Nm (88.5 ft lb) admissible for main travelling direction with gear lever set to «B»

MODEL	RATIO		POWER / RPM		INPUT POWER CAPACITY						MAX RPM	WEIGHT		BELL HSGS. AND NOTES
	«A» Pos	«B»Pos	kW	hp	3000 rpm		3600 rpm		3800 rpm			kg	lb	
					kW	hp	kW	hp	kW	hp				
ZF 15 M	1.556	1.955	0.0152	0.0204	46	61	55	73	55	74	13	29	SAE 4, 5, 6, B/W, Yanmar JH Max input power 55 kW. Ratio 1.556 «B» Pos. max torque 120 Nm. Ratio 1.875 «B» Pos. max torque 120 Nm.	
	1.875	1.955												

«A» POS = continuous running position (normally AHEAD).

«B» POS = reverse position.

B/W = Borg Warner adaptor.

Note = For all «M» (Mechanical) transmissions reduce power capacity by the following shock factors: 1 cylinder engine ÷ 1.25, 2 cylinder engine ÷ 1.20, 3 cylinder engine ÷ 1.15.



## Radni Priručnik ZF 4-1 M / ZF 30 M

**K = 1.25 to be applied, if engine has 1 cylinder / K = 1.20 for 2 cylinders / K = 1.15 for 3 cylinders**

\*\* Max. 120 Nm (88.5 ft lb) admissible for main travelling direction with gear lever set to «B»

MODEL	RATIO		POWER / RPM		INPUT POWER CAPACITY						MAX RPM	WEIGHT		BELL HSGS. AND NOTES
	«A» Pos	«B»Pos	kW	hp	kW	hp	kW	hp	kW	hp		kg	lb	
					3000 rpm	3600 rpm	3800 rpm							
ZF 15 MA 8 degrees	1.875	1.955	0.0152	0.0204	46	61	55	73	55	74	13.5	30	SAE 4, 5, 6, B/W, Yanmar JH Max input power 55 kW. <b>Ratio 1.875 «B» Pos. max torque 120 Nm. Ratio 2.136 «B» Pos. max torque 120 Nm.</b>	
	2.136	1.955	0.0131	0.0176	39	53	47	63	50	67				
	2.632	1.955	0.0111	0.0149	33	45	40	54	42	57				

**K = 1.25 to be applied, if engine has 1 cylinder / K = 1.20 for 2 cylinders / K = 1.15 for 3 cylinders**

\* Max. 120 Nm (88.5 ft lb) admissible for main travelling direction with gear lever set to «B».

\*\* Max 45 kW for main travelling direction with gear lever set to «B».

MODEL	RATIO		POWER / RPM		INPUT POWER CAPACITY						MAX RPM	WEIGHT		BELL HSGS. AND NOTES
	«A» Pos	«B»Pos	kW	hp	kW	hp	kW	hp	kW	hp		kg	lb	
					3000 rpm	3600 rpm	3800 rpm							
ZF 15 MIV 8 degrees	2.134	2.224	0.0152	0.0204	46	61	55	73	55	74	21	47	SAE 4, 5, B/W, Yanmar JH Max input power 55 kW. <b>Ratio 2.134 «B» Pos. max torque 120 Nm.</b>	
	2.718	2.224	0.0111	0.0149	33	45	40	54	42	57				
	2.995	2.224												

**K = 1.25 to be applied, if engine has 1 cylinder - K = 1.20 for 2 cylinders - K = 1.15 for 3 cylinders**

\*\* Max. 230 Nm (170 ft lb) admissible for main travelling direction with gear lever set to «B»

MODEL	RATIO		POWER / RPM		INPUT POWER CAPACITY						MAX RPM	WEIGHT		BELL HSGS. AND NOTES
	«A» Pos	«B»Pos	kW	hp	kW	hp	kW	hp	kW	hp		kg	lb	
					3000 rpm	3600 rpm	3800 rpm							
ZF 25 M	1.880	2.095	0.0262	0.0351	79	105	80	107	80	107	18.5	41	SAE 4, 5, B/W, Yanmar JH Max input power 80 kW. <b>Ratio 1.880 «B» Pos. max torque 230 Nm.</b>	
	2.273	2.095	0.0216	0.0289	65	87	78	104	80	107				
	2.737	2.722	0.0177	0.0237	53	71	64	85	67	90				

**K = 1.25 to be applied, if engine has 1 cylinder / K = 1.20 for 2 cylinders / K = 1.15 for 3 cylinders**

\*\* Max. 169 Nm (125 ft lb) admissible for main travelling direction with gear lever set to «B»

MODEL	RATIO		POWER / RPM		INPUT POWER CAPACITY						MAX RPM	WEIGHT		BELL HSGS. AND NOTES
	«A» Pos	«B»Pos	kW	hp	kW	hp	kW	hp	kW	hp		kg	lb	
					3000 rpm	3600 rpm	3800 rpm							
ZF 25 MA 8 degrees	2.227	2.737	0.0215	0.0288	64	86	77	104	80	107	21.1	47	SAE 4, 5, B/W, Yanmar JH Max input power 80 kW. <b>Ratio 2.227 «B» Pos. max torque 169 Nm.</b>	
	2.737	2.737	0.0177	0.0237	53	71	64	85	67	90				

**K = 1.25 to be applied, if engine has 1 cylinder / K = 1.20 for 2 cylinders / K = 1.15 for 3 cylinders**

\*\* Max. 185 Nm (137 ft lb) admissible for main travelling direction with gear lever set to «B»

MODEL	RATIO		POWER / RPM		INPUT POWER CAPACITY						MAX RPM	WEIGHT		BELL HSGS. AND NOTES
	«A» Pos	«B»Pos	kW	hp	kW	hp	kW	hp	kW	hp		kg	lb	
					3000 rpm	3600 rpm	3800 rpm							
ZF 30 M	2.148	2.636	0.0241	0.0323	72	97	87	116	92	123	23	51	4 & 5 Yanmar JH Max input power 95 kW. <b>Ratio 2.148 «B» Pos. max torque 185 Nm. Ratio 2.696 «B» Pos. max torque 185 Nm.</b>	
	2.696	2.636												

«A» POS = continuous running position (normally AHEAD).

«B» POS = reverse position.

B/W = Borg Warner adaptor.

Note = For all «M» (Mechanical) transmissions reduce power capacity by the following shock factors: 1 cylinder engine ÷ 1.25, 2 cylinder engine ÷ 1.20, 3 cylinder engine ÷ 1.15.

## 9.1 Jamstvo

### 9.1.1 UVJETI JAMSTVA

Proizvođač ZF Marine Arco S.p.A. daje jamstvo za brodске prijenose serije ZFM za bilo kakvu nedostatak materijala i/ili radne snage, za korištenje u normalnim uvjetima i u slučajevima kad je izvršeno propisano redovno održavanje. Ovo jamstvo vrijedi samo kada je montaža ispravno izvedena i kada se prijenos koristi na ispravan način.

Obveza tvrtke ZF Marine Arco S.p.A. po ovom jamstvu ograničena je na zamjenu ili popravak (prema vlastitoj odluci) dijela ili dijelova koje je ZF Marine Arco S.p.A., nakon pregleda istih, priznala kao neispravne, pod uvjetom da su dio ili dijelovi vraćeni u najbliži ovlašteni servis i da su transportni troškovi plaćeni unaprijed, i to unutar razdoblja: dvadesetčetiri (24) mjeseca od datuma montaže ili tridesetšest (36) mjeseci od datuma dopreme proizvođaču motora; vrijedi uvjet koji ističe ranije. Obveze ZF Marine Arco S.p.A. po ovom jamstvu, kako je prije navedeno, također ovise i o poštivanju Postupaka jamstva (koji su sastavni dio ovoga jamstva) prodavača ili proizvođača motora, koji su proizvod stavili na tržište.

Svi zahtjevi za ostvarenje prava jamstva moraju se podnijeti prodavaču ili proizvođaču motora koji se ZF prijenos stavili na tržište.

Ovo jamstvo ne vrijedi ukoliko su jedan ili više elemenata popravljani ili prepravljani bez prijašnje pismene suglasnosti ovlaštenog dobavljača ZF Marine Arco S.p.A. Ovo jamstvo ne vrijedi ukoliko se proizvod ili njegove komponente ili dijelovi neispravno ili nemarno koriste, prepravljaju ili su podložni nezgodama ili pak rad pojedinih dijelovi nije u skladu s pisanim uputama ZF Marine Arco S.p.A. ili je njihov režim rada bio teži ili u svakom slučaju preko opisanog režima rada za pojedini proizvod ili su dijelovi montirani i pušteni u rad na neispravan način. Ovo jamstvo zamjenjuje sva ostala eksplicitna ili implicitna jamstva koja uključuju jamstva prodaje i ispravnoga korištenja te eventualne ostale obveze koje uključuju štete prouzročene korištenjem proizvoda. Tvrtka ZF Marine Arco S.p.A. nije odgovorna niti ovlašćuje ostale osobe da prihvate druge odgovornosti vezane za prodaju broskog prijenosa ZFM. Tvrtka ZF Marine Arco S.p.A. u svakom slučaju nije odgovorna za štete veće od tržišne vrijednosti broskog prijenosa ZFM.

### 9.1.2 TORZIONA ODGOVORNOST I TORZIONA ELASTIČNA SPOJKA

Odgovornost za sigurnost torzione kompatibilnosti stoji na onome tko sastavlja pogon i pogonsku opremu. ZF Marine S.p.A. ne može preuzeti odgovornost za buku kopče (mjenjačke

kutije) štetu izazvanu vibracijama, za elastičnu spojku ili za oštećenja drugih dijelova pogona uzrokovanih tom vrstom vibracija.

Kontaktirajte ZF Marine S.p.A. za daljnje informacije i asistenciju.

ZF Marine S.p.A. preporučuje upotrebu torsional limit stop-a za brodove sa jednim motorom, gdje gubitak pogonske snage može rezultirati gubitkom kontrole.

Odgovornost kupca je da navede tu mogućnost koja može rezultirati dodatnim troškovima i mogućim povećanjem dužine instalacije.

ZF Marine S.p.A. ne može prihvatiti odgovornost za povredu osoba, gubitak života, ili oštećenje, te materijalni gubitak nastao propustom kupca koji nije specificirao torsional limit stop.

ZF Marine S.p.A. odabire elastičnu spojku na osnovi procjene nominalne ulazne torzije i uobičajeno prihvaćenih brzina upravljanja motorom.

Savjetujte se sa ZF Marine S.p.A.-om oko detalja vezanih uz ograničenje brzine standardno ponuđene elastične spojke koja može biti manja od ograničenja prijenosa.

Posebna torziona elastična spojka može biti tražena za SSIC (Survey Society Ice Classification) uvjete.



## 10.1 List of recommended fluids

ADDINOL MINERALÖL GMBH, KRUMPA/D	ADDINOL ATF D IID	KUWAIT PETROLEUM, HOOGLVIET/NL	Q8 AUTO 14 (IID-21883)
ADDINOL MINERALÖL GMBH, KRUMPA/D	ADDINOL ATF D III	LEPRINCE+SIVEKE GMBH, HERFORD/D	LEPRINXOL FLUID CN
AGIP PETROLI SPA, ROM/I	AGIP ATF II D	LIQUI MOLY / MEGUIN, ULM/D	ATF IIE
AGIP PETROLI SPA, ROM/I	AGIP ATF D 309	LIQUI MOLY / MEGUIN, ULM/D	MEGOL ATF IID
AGIP PETROLI SPA, ROM/I	AGIP ATF PLUS	LUBRICATION ENGIN., FORT WORTH/USA	AUTOMATIC TRANSMISSION FLUID
AGIP PETROLI SPA, ROM/I	AGIP DEXRON III	MAURAN SA, ODARS/F	INTER OIL INTER Matic ATF D2
AGIP SCHMIERTECHNIK, WÜRZBURG/D	AUTOL GETRIEBEÖL ATF-D	MIN.ÖL-RAFFIN. DOLLBERGEN, UETZE/D	PENNASOL FLUID-GETR.ÖL TYP PCN
AGIP SCHMIERTECHNIK, WÜRZBURG/D	AUTOL GETRIEBEÖL ATF III D	MOBIL OIL, WEDEL/D	MOBIL ATF 220 D20104 / D21685
ARAL LUBRICANTS GMBH, BOCHUM/D	ARAL GETRIEBEÖL ATF 22	MOBIL OIL, WEDEL/D	MOBIL ATF F-30107
ARAL LUBRICANTS GMBH, BOCHUM/D	ARAL GETR.ÖL ATF 55 F-30589	MOBIL OIL, WEDEL/D	MOBIL ATF 220 D21412 / D22187
AVIA MINERALÖL-AG, MÜNCHEN/D	AVIA FLUID ATF 86	MOBIL SEKIYU KABUS.KAISHA, TOKYO/J	MOBIL ATF 220Y (D-21412)
BLASER SWISSLUBE, HASLE-RÜEGSAU/CH	BLASOL 229	MOL HUNGARIAN OIL, KOMARON/H	CARRIER ATF
BP OIL DEUTSCHLAND, HAMBURG/D	FRONTOL UNIVERSAL-ATF 100	MORRIS LUBRICANTS, SHREWSBURY/GB	LIQUIMATIC DII
BP OIL INTERNATIONAL, LONDON/GB	AUTRAN DX II	NAFTEC, ALGIER/DZ	TASSILIA
BP OIL INTERNATIONAL, LONDON/GB	AUTRAN MBX	NANHAI SUPERIOR LUB-OIL, CHINA	NANHAI ATF (D2)
BP OIL INTERNATIONAL, LONDON/GB	AUTRAN DX III (F-30370)	NIS-RAFINERIJA NAFTA BEOGRAD/YU	GALAX Matic DAC
BP OIL INTERNATIONAL, LONDON/GB	AUTRAN DX III (F-30381)	OEST G. MIN.ÖLWERK, FREUDENSTADT/D	ATF T 4011
BUCHER+CIE AG, LANGENTHAL/CH	MOTOREX ATF SUPER D-22656	OMEX PETROLEUM PTY, BELLEVUE/AUS	OMEX ATF DEXRON II
BUCHER+CIE AG, LANGENTHAL/CH	MOTOREX ATF DEXRON III MC	OMV AG, SCHWECHAT/A	OMV ATF D II (D22427)
CALPAM GMBH, ASCHAFFENBURG/D	PAMATIC FLUID 289	OMV AG, SCHWECHAT/A	OMV ATF III (F-30580)
CALPAM GMBH, ASCHAFFENBURG/D	CALPAMATIC FLUID III F	OPTIMOL ÖLWERKE, HAMBURG/D	OPTIMOL ATF T 4011
CALTEX PETROLEUM CORP., LONDON/GB	CALTEX ATF-HDA	OSWALD KLUTH, BARGFELD-STEGEN/D	UNIVERSAL ATF-D
CALTEX PETROLEUM CORP., LONDON/GB	CALTEX ATF-HDM	PAKELO MOTOR OIL, SAN BONIFACIO/I	MULTIPURPOSE TRANSM. FLUID IID
CALTEX PETROLEUM CORP., LONDON/GB	CALTEX TEXAMATIC 1278	PANOLIN AG, MADETSWIL/CH	PANOLIN ATF MULTI 21996
CALTEX PETROLEUM CORP., LONDON/GB	CALTEX TEXAMATIC 7045	PANOLIN AG, MADETSWIL/CH	PANOLIN ATF DEXRON III
CALTEX PETROLEUM CORP., LONDON/GB	CALTEX TEXAMATIC 1205A	PARS OIL CO., TEHRAN/IR	PARS ENTEGHAL-E AUTOMATIC OIL
CASTROL LTD, SWINDON/GB	CASTROL TQ-D (22765)	PAZ LUBRICANTS&CHEMICALS, HAIFA/IL	PAZBO EZF
CASTROL LTD, SWINDON/GB	CASTROL TQ DEXRON III F-30520	PENNZOIL PRODUCT COMP., HOUSTON/USA	PENNZOIL ATF F-30110
CASTROL LTD, SWINDON/GB	CASTROL TRANSMAX S (F-30319)	PETRO-CANADA, MISSISSAUGA/CDN	DEXRON III/MERC.ATF (F-30395)
CASTROL LTD, SWINDON/GB	CASTROL TRANSMAX T (F-30359)	PETROL OFISI A.S., BAKANLIKLAR/TR	PETROL OFISI ATF II
CASTROL LTD, SWINDON/GB	CASTROL TQ-D (21289)	PETROLEX, KWIDZYN/PL	VECO Matic IID
CASTROL LTD, SWINDON/GB	CASTROL ATF 21293	PRINZ-SCHULTE, FRECHEN/D	AERO-LINE ATF-2
CEPSA, MADRID/E	CEPSA ATF-70	PRINZ-SCHULTE, FRECHEN/D	AERO-LINE ATF-D
CHEVRON PRODUCTS CO., RICHMOND/USA	CHEVRON ATF F-30108	REPSOL DISTRIBUTION SA, MADRID/E	REPSOL Matic ATF
CITGO PETROLEUM CORP., TULSA/USA	CITGO ATF DEXRON III F-30167	S.A.E.L., ALCOBENDAS/E	GULF ATF DII D-22233
C.J.DIEDERICH'S SÖHNE, WUPPERTAL/D	CIDISOL-HYDR.-FLUID DEXRON IID	SASOL OIL, RANDBURG/ZA	SASOL ATF DXII
DE OLIEBRON B.V., ZWIJNDRECHT/NL	ATF DMM	SCHMIERSTOFFRAFFINERIE SALZBERGEN/D	WINTERSHALL ATF D
DE OLIEBRON B.V., ZWIJNDRECHT/NL	ATF 289	SHELL ASEOL AG, BERN/CH	ASEOL ATF DB UNIVERSAL
DEA MINERALÖL AG, HAMBURG/D	DEAMATIC	SHELL INTERNATIONAL, LONDON/GB	SHELL DONAX TA (D-21666)
DEA MINERALÖL AG, HAMBURG/D	DEAFLUID 4011	SHELL INTERNATIONAL, LONDON/GB	SHELL DONAX TG (F-30358)
DEA MINERALÖL AG, HAMBURG/D	DEAFLUID 3003	SLOVNAFT JS CO, BRATISLAVA/SLO	MADIT AUTOMATIC
DEUTSCHE SHELL AG, HAMBURG/D	MAC ATF D-21666	SONOL ISRAEL LTD, HAIFA/IL	DEXRON 2 D
DUCKHAMS OIL, BROMLEY/GB	UNIMATIC	SOPROGRASA SA, MADRID/E	SOPRAL 164
ELF LUBRIFIANTS, PARIS/F	TRANSANTAR DF2	STATOIL STAVANGER/N	TRANSWAY DX III (F-30373)
ELF LUBRIFIANTS, PARIS/F	ANTAR 22329	STATOIL STAVANGER/N	TRANSWAY DX II
ELF LUBRIFIANTS, PARIS/F	ELFMATIC G2 22329	STL TECNOL, ESCALQUENS/F	TECNOL TECMATIC D2
ELF LUBRIFIANTS, PARIS/F	HUILE RENAULT DIESEL STARMATIC	SUN OIL COMPANY, AARTSELAAR/B	SUNAMATIC 149
ELF LUBRIFIANTS, PARIS/F	ELFMATIC G3	SUN OIL COMPANY, AARTSELAAR/B	SUNAMATIC 153
ELF LUBRIFIANTS, PARIS/F	TRANSANTAR DF3	SUOMEN PETROOLI OY, HAMINA/SF	TEBOIL FLUID E (F-30301)
ELLER-MONTAN-COMP., DUISBURG/D	ELLMO-AUTOMATIK-FLUID 22233	SUOMEN PETROOLI OY, HAMINA/SF	TEBOIL FLUID D
ENGEN PETROLEUM, CAPE TOWN/ZA	ENGEN ATF 22D	SVENSKA STATOIL AB, NYNÄSHAMN/S	TRANSWAY DX III (F-30373)
ERTOIL SA, MADRID/E	TRANSMISIONES AUTOMATICAS D2	TAMOIL LUBES, GENEVA/CH	TAMOIL ATF II D
ESSO AG, HAMBURG/D	ESSO ATF D (21611)	TEXACO LUBRICANTS COMP., BEACON/USA	ATF MERCON / DEXRON III
ESSO AG, HAMBURG/D	ESSO ATF F-30320	TEXACO SERVICES LTD, BRÜSSEL/B	TEXAMATIC 7045
ESSO AG, HAMBURG/D	ESSO ATF D (21065)	TEXACO SERVICES LTD, BRÜSSEL/B	TEXAMATIC 4261
FIAT LUBRIFICANTI, VILLASTELLONE/I	TUTELA GI/A	TEXACO SERVICES LTD, BRÜSSEL/B	TEXAMATIC 7080
FINA EUROPE SA, BRÜSSEL/B	FINAMATIC II-D	TEXACO SERVICES LTD, BRÜSSEL/B	TEXTRAN PSM
FUCHS LUBRICANTS (UK), DERBY/GB	SILKTRAN MP-ATF	TEXACO SERVICES LTD, BRÜSSEL/B	TEXAMATIC 4011
FUCHS LUBRICANTS (UK), DERBY/GB	SILKTRAN PSV ATF	TEXACO SERVICES LTD, BRÜSSEL/B	TEXAMATIC 4291
FUCHS MINERALÖLWERKE, MANNHEIM/D	TITAN ATF 4000	TEXACO SERVICES LTD, BRÜSSEL/B	TEXAMATIC 9226
GINOUVES GEORGES SA, LA FARLEDE/F	YORK LT 785	TOTAL RAFFINAGE DISTR., PARIS/F	TOTAL FLUIDE ATX
GULF OIL (GB) LTD, CHELTENHAM/GB	UNIFLUID	TOTAL RAFFINAGE DISTR., PARIS/F	TOTAL FLUIDE IID
GULF OIL (GB) LTD, CHELTENHAM/GB	ATF 2	TOTAL RAFFINAGE DISTR., PARIS/F	TOTAL FLUIDE AT 42
HANDELSMIJ NOVIO B.V., NIJMEGEN/NL	KENDALL ATF DEXRON IID	TOTAL SOUTH AFRICA, JOHANNESBURG/ZA	TOTAL FLUIDE ATD
HOMBERG GMBH+CO KG, WUPPERTAL/D	HOMBERG-GETRIEBE-FLUID D	TURBOTANK BÖSCHE+BÖDEKER, BREMEN/D	TURBO UNIV. ATF MERCON 4011
IGOL FRANCE, PARIS/F	IGOL ATF 420	UFANEFTTECHIM REFINERY, UFA/RUS	UFALUB ATF
INA RAFINERIJA ZAGREB/CROATIA	INA-ATF SUPER	UNIL DEUTSCHLAND GMBH, BREMEN/D	UNIL Matic CN T 4011
ITALIANA PETROLI, GENOVA/I	TRANSMISSION FLUID DX	VALVOLINE INC., LEXINGTON/USA	VALVOLINE MULTI-PURPOSE ATF
JAPAN ENERGY CORP., TOKYO/JAPAN	JOMO ATF K	VALVOLINE INTERNAT., DORDRECHT/NL	VALVOLINE ATF TYPE D
KÄPPLER K., STUTTGART/D	SELECTOL FLUID GETR.ÖL IID 23	VEBA OEL AG, GELSENKIRCHEN/D	MOVARA ATF-GETRIEBEÖL DIID
KLÖCKNER ENERGIEHANDEL GMBH, KÖLN/D	DEUTZ OEL ATF-D	VEEDOL INTERNATIONAL, SWINDON/GB	VEEDOL ATF-M (22764)
KROON OIL BV, ALMELO/NL	ATF DEXRON IID	VEEDOL INTERNATIONAL, SWINDON/GB	VEEDOL ATF DEXRON III F-30521
KROON OIL BV, ALMELO/NL	ALMIROL ATF	VEEDOL INTERNATIONAL, SWINDON/GB	VEEDOL UNITRANS S PLUS
KUWAIT PETROLEUM, HOOGLVIET/NL	Q8 AUTO 15	YACCO SA, ST PIERRE-LES-ELBEUF/F	YACCO ATF D
KUWAIT PETROLEUM, HOOGLVIET/NL	Q8 AUTO 14 (IID-21677)	ZELLER+GMELIN GMBH&CO, EISLINGEN/D	DIVINOL FLUID 666
KUWAIT PETROLEUM, HOOGLVIET/NL	Q8 AUTO 14 (IID)		



## 11.1 Dealer List

### AUSTRALIA

**ZF AUSTRALIA PTY. LTD.**  
14 Lidco St. Arndell Park  
NSW 2148  
Tel. +61 (0)2 9679 5555  
Fax +61 (0)2 9679 5500  
E-mail: mailbox@zf.com.au

### BRAZIL

**ZF DO BRASIL Ltda**  
Avenida Conde Zeppelin, 1935  
CEP 18103-905 Sorocaba-SP  
BRASIL  
Tel. +55 (0)15 4009 2389  
Fax +55 (0)15 4009 2233  
E-mail: marine.info@zf-group.com.br

### BELGIUM

See Netherlands

### CHINA

**ZF PD SHANGHAI**  
**Representative Office**  
Room 2504, Jiangnan Building,  
No. 600 Luban Road  
Shanghai 200023  
P.R. CHINA  
Tel. +86 (0) 21 6301 4338  
Fax +86 (0) 21 6301 6449  
E-mail: zhouqing.tang@zf.com

### CROAZIA

**ITEC d.o.o.**  
Tommy Malpera  
Ul. Kneza Domagoja 10  
47 000 Karlovac  
Mat. Br. 1734083  
Tel. +385 (047) 631755  
Tel. +385 (047) 631756  
Hendy: +385 (047) 3337440  
Hendy: +385 (091) 3337442  
E-mail: nautica@itec.hr

### CYPRUS

**CHAR. PILAKOUTAS Ltd.**  
P.O. Box 1168, 7 Lamaca Road  
1503 Nicosia  
Tel. +357 22 349 572  
Fax +357 22 349 952  
E-mail: pambos@charpilakoutas.com.cy

### DENMARK

**ZF DANMARK ApS**  
Taastrupgaardsvej 8-10  
DK-2630 Taastrup  
Tel. +45 (0)43 436243  
Fax +45 (0)43 432643  
E-mail: zfdk@zf.com

### FINLAND

**ATOY OY**  
Ruukintie 7-9  
FIN-02330 Espoo  
Tel. +358 (0) 9 682 71  
Fax +358 (0) 9 6827 305  
E-mail: matti.vahatalao@atoy.fi

### FRANCE

**ZF FRANCE S.a.r.l.**  
Z.I. - 3-11 Rue Henri Poincaré  
F-92 167 Antony Cédex  
Tel. +33 (0)1 4096 4265  
Fax +33 (0)1 4096 4285  
E-mail: raymond.gouge@zf.com

### GERMANY

**ZF MARINE GmbH ZF Hurth Marine Rep.**  
Zamdorferstrasse 90  
D-81677 München  
Tel. +49 (0)89 930094 63/64  
Fax +49 (0)89 930094 21  
E-mail: guenther.koepfel@zf.com

### GREECE

**EURODIESEL K. & E. MALERDOS CO.**  
20 Ymittou str.  
18540 Piraeus, GREECE  
Tel. 0030.210.4172488, 4179693  
Fax 0030.210.4175441  
E-mail: malerdos@otenet.gr

### TEKMAR Ltd

15 Ethn. Makariou Str.  
GR-185 47 Neofaliro Piraeus  
Tel. +30 (0)210 4820814  
Fax +30 (0)210 4811803  
E-mail: tekmar@hol.gr

### ISRAEL

**NIMDA CO. Ltd.**  
Lev Pesach Street  
North Industrial Zone, Lod 71293  
P.O. Box 768, Lod 71293  
Tel. +972 (0)8 9781 111  
Fax +972 (0)8 9781 137  
E-mail: davni@dslnim.co.il

### ITALY

**ZF MARINE ARCO S.p.A.**  
Via S. Andrea, 16  
I-38062 Arco (TN)  
Tel. +39 0464 580555  
Fax +39 0464 580544  
E-mail: info.zfthurth@zf.com

### ZF ITALIA S.r.l.

Via Donizetti, 11  
I-20090 Assago (MI)  
Tel. +39 02 4888 31  
Fax +39 02 4884 3807  
E-mail: marine@zf-group.it

### JAPAN

**ZF Japan Co. Ltd.**  
Fujikoshi Building, 1 - 10 - 11  
Iriya Taito-ku  
Tokyo 110-0013  
Tel. +81 (0)3 5808 4521  
Fax +81 (0)3 5808 4531  
E-mail: satom@zf-marine.co.jp

### KOREA (SOUTH)

**ZF KOREA CO. Ltd.**  
422-2 Chongchon-dong  
Bupyong-Gu  
Incheon, 403-032  
Rep. of KOREA  
Tel. +82 (0)32 5051 508  
Fax +82 (0)32 5051 514  
E-mail: chun.bs@zf-group.co.kr

### LUXEMBURG

See Netherlands

### MALTA

**OCEANS**  
9, Main Street  
Zurrieq ZRQ 03  
Tel. +356 (0)21 640 703  
Fax +356 (0)21 641 223  
E-mail: mylake@maltanet.net

### NETHERLANDS

**ADS van STIGT**  
Avelingen - West 30  
NL - 4202 MS Gorinchem  
Tel. +31 (0)183 650 000  
Fax +31 (0)183 650 001  
E-mail: info@vanstigt.com

### NORWAY

**KGK NORGE AS**  
Caspar Storms Vei 19  
N-0664 Oslo  
Tel. +47 (0)22 720 575  
Fax +47 (0)22 720 902  
E-mail: karl.baumgart@zf-group.no

### POLAND

**VOLVO PENTA POLSKA Sp. z o.o.**  
Prostokatna 5A Str.  
81-601 Gdynia  
Tel. +48 (0)58 627 3380  
Fax +48 (0)58 627 3390  
E-mail: mirek.czurak@volvopenta.pl

### RUSSIA

**ZF MARINE RUSSIA**  
Suite 404, Obvodny Kanal Emb.,118  
190005 Saint Petersburg  
Tel. +7 812 441 37 94  
Fax +7 812 441 37 94  
E-mail: alexander.lyshkov@zf.sp.ru

### SINGAPORE

**ZF SOUTH EAST ASIA Pte.Ltd**  
11 Tuas Drive 1  
638678 Singapore  
Tel. +65 6424 8731  
Fax +65 6424 8788  
E-mail: singapore@zf-sea.com.sg

### SOUTH AFRICA

**ZF of SOUTH AFRICA Pty. Ltd.**  
Meadowdale Ext. 3  
170 Herman Road  
1401 Germiston Johannesburg  
Tel. +27 (0)11 457 0000  
Fax +27 (0)11 453 7506  
E-mail: pierre@zfsa.co.za

### SPAIN

**ZF ESPAÑA, S.A.**  
Avenida Fuentemara, 11  
E-28820 Costlada, Madrid  
Tel. +34 (0)91 485 2698  
Fax +34 (0)91 485 0036  
E-mail: marine.zfesp@zf.com

### SWEDEN

**KG KNUTSSON AB**  
**Transmissionsdivisjonen**  
Hammarbacken 8  
SE-191 81 Sollentuna  
Tel. +46 (0)8 923 000  
Fax +46 (0)8 929 599  
E-mail: karl-henry.pragsten@kgk.se

### TURKEY

**NIVEKO Makina Ticaret Limited**  
Takkeci Sokak No. 3  
TR-34345 Arnavutköy - Istanbul  
Tel. +90 (0)212 287 2780  
Fax +90 (0)212 287 6571  
E-mail: georg@niveko.com

### UNITED KINGDOM

**ZF GREAT BRITAIN Ltd.**  
Abbeyfield Road, Lenton  
Nottingham NG7 2SX  
Tel. +44 (0)115 986 9211  
Fax +44 (0)115 8515 508  
E-mail: zfmachine@zf-group.co.uk

### UNITED ARAB EMIRATES

**ZF MARINE MIDDLE EAST LLC**  
Office No. 502 & 503  
Golden Tower Building  
opposite to Marbella Club  
Buheira Corniche,  
P.O. BOX 26093  
Sharjah - U.A.E.  
Tel. + 971 6 574 7074  
Fax. + 971 6 574 7174  
E-mail: narasimhan.manian@zf.com

### U.S.A.

**ZF MARINE, LLC.**  
**(U.S. HEADQUARTERS)**  
Pleasure Craft, Propulsion, Latin America, Caribbean,  
After Market)  
3131 Southwest 42nd Street  
Fort Lauderdale, FL 33312  
U.S.A.  
Tel. +1 954 581 4040  
Latin America +1 954 581 4063  
Fax +1 954 581 4078-77  
E-mail: Info.ZFMarineFtLauderdale@zf.com

### ZFI MARINE, LLC West Coast

**(Commercial and Fast Craft)**  
12125 Harbor Reach Drive, Ste.B  
Mukilteo, WA 98275 U.S.A.  
Tel. +1 425 583 1900  
Fax +1 425 493 1579  
Toll Free 800 546 5455  
E-mail: Info.ZFMarineWashington@zf.com



# 12.1 Installation Layout

ZF 5 M

SPAZIO NECESSARIO PER L'ESTRAZIONE DELL'ASTA LIVELLO OLIO / EXTENSIONARY FOR OILSTICK

PIANO DI RIFERIMENTO X1 / FACE OF REFERENCE X1

ALBERO INGRESSO / INPUT SHAFT

UTILE AVAILABLE

Ø105 N° 4 FORI/HOLES

Ø64 N°2 FORI/HOLES

SENDO DI ROTAZIONE IN ENTRATA / DIRECTION OF INPUT ROTATION

MB N°6 FORI PROF.12mm (COPPIA DI SERR.14Nm) / MB No.6 HOLES 12mm DEEP (TIGHTENING TORQUE 14Nm)

ESCURSIONE LEVA COMANDO PER L'INNESTO / LEVER STROKE FOR IN-GEAR

ESCURSIONE MINIMA PER L'INSERIMENTO MARCIA (A e B) / MIN. STROKE FOR IN-GEAR MODE (A and B)

ESCURSIONE MASSIMA CON MARCIA INSERITA (A e B) / MAX. STROKE WHEN IN-GEAR (A and B)

PER FISSAGGIO STAFFA TELECOMANDO / TO INSTALL CONTROL CABLE BRACKET

MB N°6 VITI/BOLTS

PER FISSAGGIO STAFFA TELECOMANDO / TO INSTALL CONTROL CABLE BRACKET

MB N°6 VITI/BOLTS

B 10x23x29 DIN5464

CONNESSIONE AL COPRIVOLANO DISPONIBILI / AVAILABLE CONNECTION TO FLYWHEEL

FORGE-WARNER

SAE 6

**CONNESSIONE AL COPRIVOLANO DISPONIBILI / AVAILABLE CONNECTION TO FLYWHEEL**

A	CONTRARIA A QUELLA DELL' ALBERO ENTRATA / OPPOSITE TO INPUT SHAFT
B	UGUALE A QUELLA DELL' ALBERO ENTRATA / SAME AS INPUT SHAFT

**INCLINAZIONE MASSIMA DURANTE IL FUNZIONAMENTO / MAX. INCLINATION DURING OPERATION**

3.2° PIANO ORIZZONTALE / HORIZONTAL PLANE

**DATEI TECNICI/TECHNICAL DATA**

Peso senza olio / WEIGHT WITHOUT FLUID	83,5 Kg / 185 LB
Quantità olio / OIL QUANTITY	0,42 l / 0,45 US
CAPACITÀ OIL / OIL CAPACITY	0,45 US
PLURIBRACCIA / MULTISHAFT	NO
PLURIBRACCIA / MULTISHAFT	NO

**G. CENTRO DI GRAVITÀ/CENTER OF GRAVITY**

4. TAPPO SCARICO OLIO/OIL DRAIN PLUG
3. SELETTORE MECCANICO/MECHANICAL SELECTOR
2. FLANGIA D'USCITA/OUTPUT FLANGE
1. TAPPO CARICO OLIO/OIL FILLING PLUG
ASTA LIVELLO OLIO/OIL DIPSTICK

**FORZA NECESSARIA PER IL MOVIMENTO DELLA LEVA DA "M" A "A" / (D. "B") 40-50 N**

**FORZA NECESSARIA PER IL MOVIMENTO DELLA LEVA DA "A" TO "B" / (D. "M") 55-65 N**

**FORZA NECESSARIA PER IL MOVIMENTO DELLA LEVA DA "M" TO "A" / (D. "B") 40-50 N**

**FORZA NECESSARIA PER IL MOVIMENTO DELLA LEVA DA "A" TO "M" / (D. "M") 55-65 N**

**ROTAZIONE DELL'ALBERO USCITA RISPETTO / ROTATION OF OUTPUT SHAFT LEVER POSITION**

A	CONTRARIA A QUELLA DELL' ALBERO ENTRATA / OPPOSITE TO INPUT SHAFT
B	UGUALE A QUELLA DELL' ALBERO ENTRATA / SAME AS INPUT SHAFT



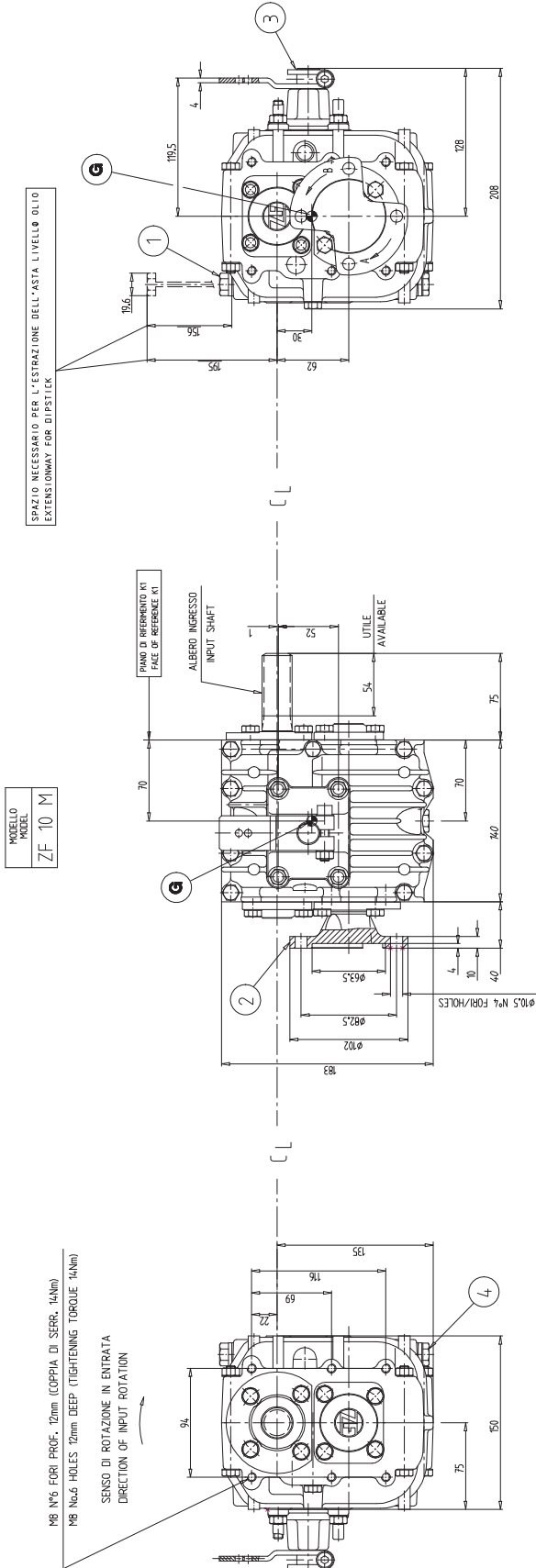

ESCURSIONE LEVA COMANDO PER L'INNESTO  
LEVER STROKE FOR IN-GEAR

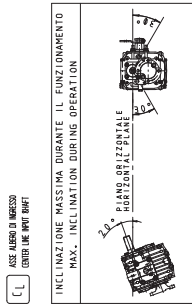
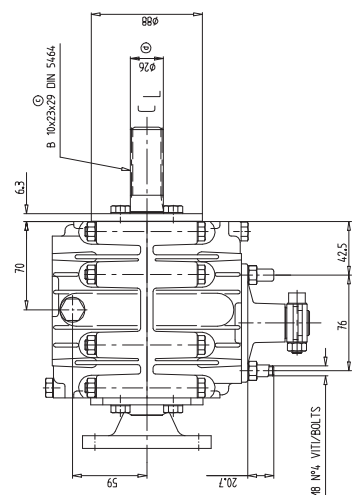
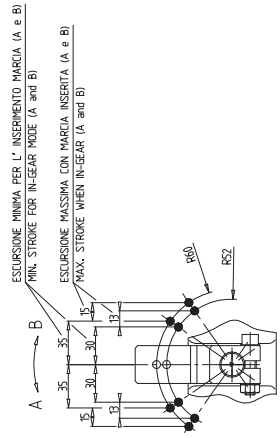

DATI TECNICI/TECHNICAL DATA	
Peso senza olio	19.3 kg
Peso con olio	21.8 kg
Capacità massima	0.45 R13
Capacità	0.45 R13
Tip. di olio	ATF
Grado di olio	AUTOMATIC TRANSMISSION FLUID

- 4 | CENTRO DI GRAVITA'/CENTER OF GRAVITY
- 4 | TAPPO SCARICO OLIO/OIL DRAIN PLUG
- 3 | SELETORE MECCANICO/MECHANICAL SELECTOR
- 2 | FLANGIA D'USCITA/OUTPUT FLANGE
- 1 | SFILATO OLIO/OIL FILLING PLUG
- ASTA LIVELLO OLIO/OIL DIPSTICK

FORZA NECESSARIA PER IL MOVIMENTO DELLA LEVA DA "N" A "A" (O "B") 40-50 N  
FORZA NECESSARIA PER IL MOVIMENTO DELLA LEVA DA "A" (O "B") A "N" 55-65 N  
SHIFTING LEVER FORCE TO ENGAGE GEAR FROM "N" TO "A" (OR "B") 40-50 N  
SHIFTING LEVER FORCE TO DISENGAGE GEAR FROM "A" (OR "B") TO "N" 55-65 N

ROTAZIONE DELL'ALBERO USCITA RISPETTO ROTATION OF OUTPUT SHAFT LEVER POSITION	
A	CONTROARIA A QUELLA DELL'ALBERO ENTRATA
B	UGUALE A QUELLA DELL'ALBERO ENTRATA

CONNESSIONI AL COPRIVOLANO DISPONIBILI AVAILABLE CONNECTION TO FLYWHEEL HOUSING	
	BORG WARNER
	SAE 4
	SAE 5
	SAE 6

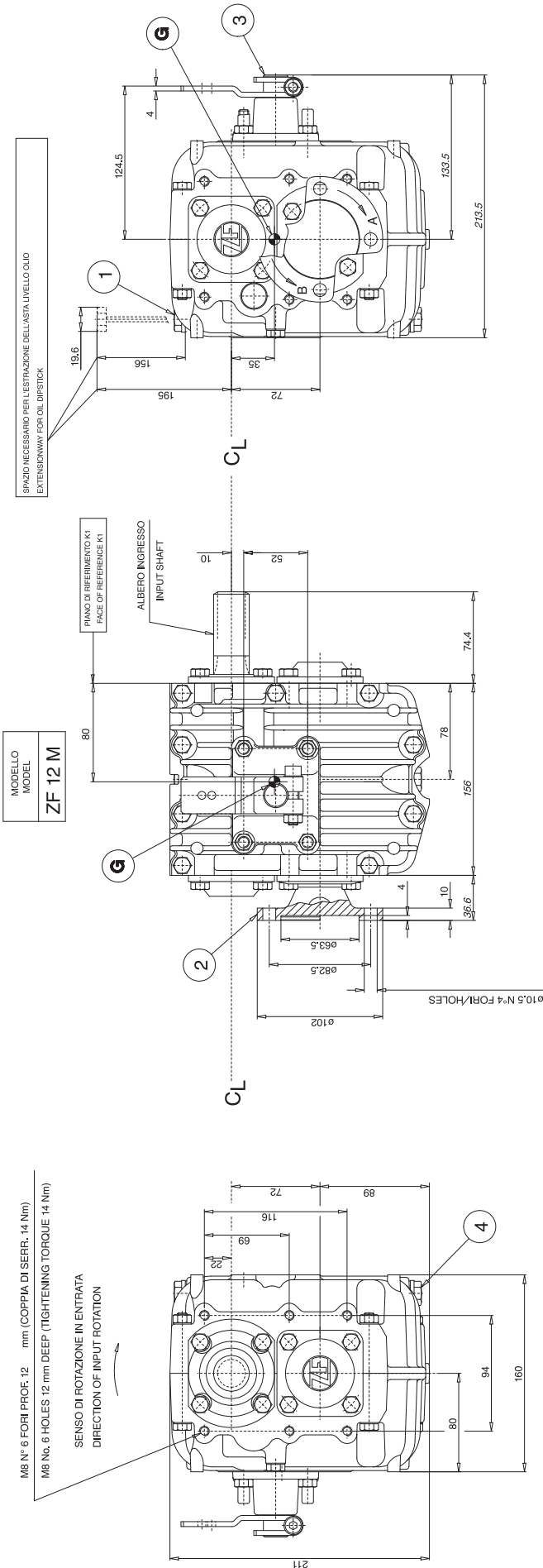

INCLINAZIONE MASSIMA DURANTE IL FUNZIONAMENTO  
MAX. INCLINATION DURING OPERATION

CL ASSE ALBERO DI INGRESSO  
CENTER LINE INPUT SHAFT

B 10x23x20 DIN5464

UTILE AVAILABLE

52

88

78

5.2

65

20.7

76

53

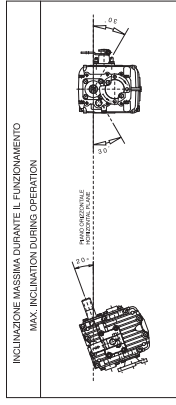

- g** CENTRO DI GRAVITA'/CENTER OF GRAVITY  
**4** TAPPO SCARICO OLIO/OIL DRAIN PLUG  
**3** SELETTORE MECCANICO/MECHANICAL SELECTOR  
**2** FLANGIA D'USCITA OUTPUT FLANGE  
**1** SFINTO OLIO/OIL BREATHER  
**1** TAPPO CARICO OLIO/OIL FILLING PLUG  
**ASTA LIVELLO OLIO/OIL DIPSTICK**

**DATI TECNICI/TECHNICAL DATA**

Peso senza olio	13 Kg
WEIGHT WITHOUT FLUID	29 LBS
Quantità olio	0.69 l
FLUID CAPACITY	0.68 QT'S
Tipo di olio	ATF
FLUID GRADE	AUTOMATIC TRANSMISSION FLUID

COPPIA NECESSARIA PER L'EVENTUALE RIMONTAGGIO DELLA LEVA 22±1 Nm.  
WHEREAS REASSEMBLY IS NEEDED TIGHTENING TORQUE 22±1 Nm.

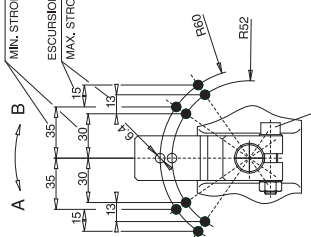







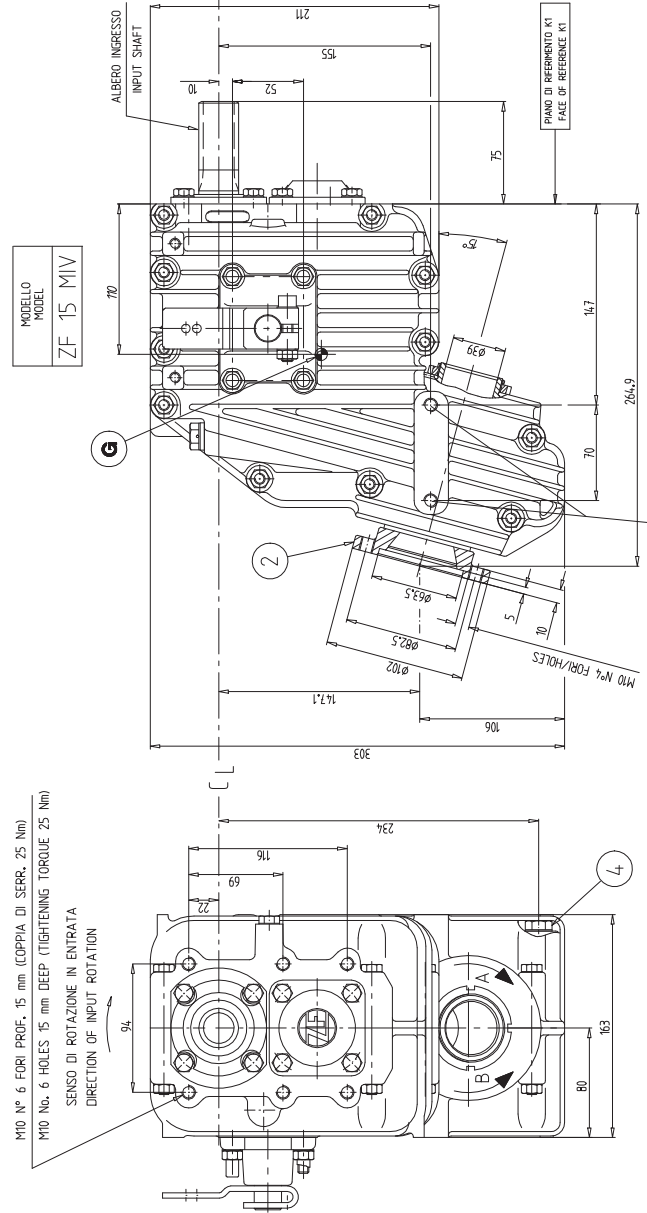
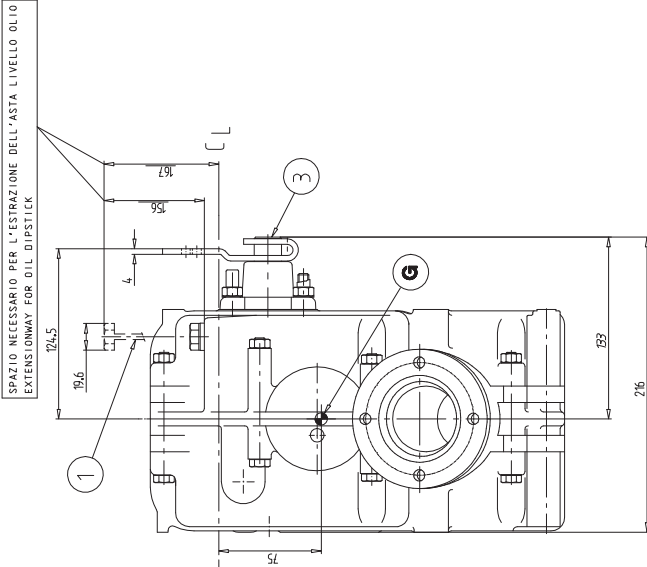

ASSE ALBERO DI INGRESSO  
INPUT SHAFT

INCLINAZIONE MASSIMA DURANTE IL FUNZIONAMENTO  
MAX. INCLINATION DURING OPERATION

PIANO ORIZZONTALE  
HORIZONTAL PLANE

1 CENTRO DI GRAVITA'/CENTER OF GRAVITY  
2 TAPPO SCARICO OLIO/OIL DRAIN PLUG  
3 SELETTORE MECCANICO/MECHANICAL SELECTOR  
4 FLANGIA USCITA/OUTPUT FLANGE  
5 SFILATO OLIO/OIL BREATHER  
6 TAPPO CARICO OLIO/OIL FILLING PLUG  
7 ASTA LIVELLO OLIO/OIL DIPSTICK

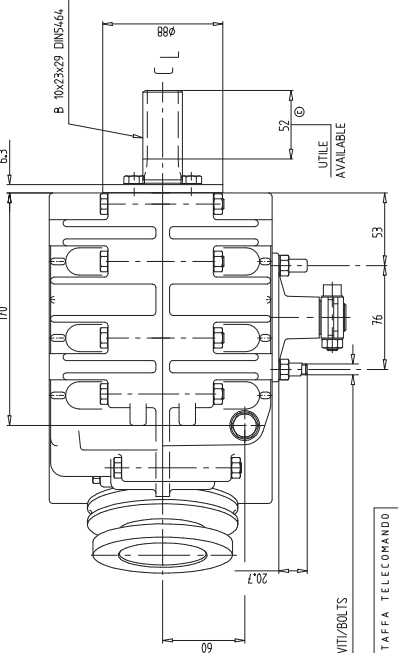

ROTAZIONE DELL'ALBERO USCITA RISPETTO ROTATION OF OUTPUT SHAFT WITH RESPECT TO THE LEVER POSITION	A
CONTRARIA A QUELLA DELL'ALBERO ENTRATA OPPOSITE TO INPUT SHAFT	B



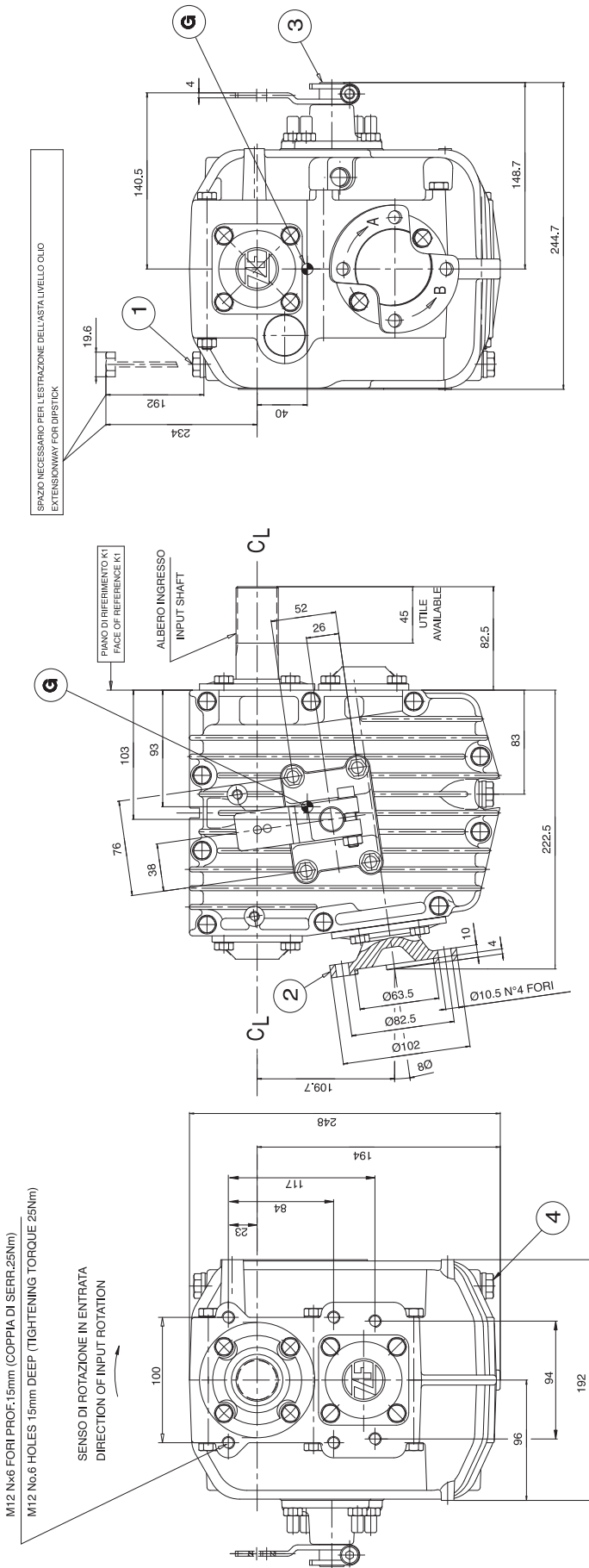

**FORZA NECESSARIA PER IL MOVIMENTO DELLA LEVA DA "N" A "A" (O "B") 40-50 N**  
**FORZA NECESSARIA PER IL MOVIMENTO DELLA LEVA DA "A" (O "B") A "N" 55-65 N**  
**SHIFTING LEVER FORCE TO ENGAGE GEAR FROM "N" TO "A" (OR "B") 40-50 N**  
**SHIFTING LEVER FORCE TO DISENGAGE GEAR FROM "A" (OR "B") TO "N" 55-65 N**

**ESCURSIONE MINIMA PER L'INSERIMENTO MARCIA (A e B)**  
**MIN. STROKE FOR IN-GEAR MODE (A and B)**

**ESCURSIONE MASSIMA CON MARCIA INSERITA (A e B)**  
**MAX. STROKE WHEN IN-GEAR (A and B)**

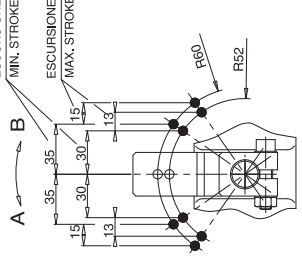

DATI TECNICI / TECHNICAL DATA	
Peso senza olio	18 KG
WEIGHT WITHOUT FLUID	39.6 LBS
Quantità olio	0,75 l
FLUID CAPACITY	0.8 QTS
Tipo di olio	ATF
FLUID GRADE	AUTOMATIC TRANSMISSION FLUID

**CL**  
**ASSE ALBERO D'INGRESSO**  
**CENTER LINE INPUT SHAFT**

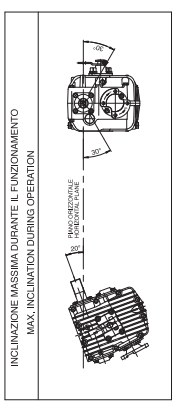

- G** CENTRO DI GRAVITA'/CENTER OF GRAVITY
- 4** TAPPO SCARICO OLIO/OIL DRAIN PLUG
- 3** SELETTORE MECCANICO/MECHANICAL SELECTOR
- 2** FLANGIA D'USCITA/OUTPUT FLANGE
- 1** TAPPO CARICO OLIO/OIL FILLING PLUG
- ASTA LIVELLO OLIO/OIL DIPSTICK







ZF 4-1 M / ZF 30 M



# ZF M WARRANTY CARD

**Standard Warranty:** ZF Marine Arco S.p.A. warrants its type ZFM Reversing Marine Transmission to be free from defects in material and work-manship under normal use and maintenance, provided that this warranty shall apply if, and only if, the equipment has been properly installed and operated. The obligation of ZF Marine Arco S.p.A. under this warranty shall be limited to the replacement or repair, at its choice, of any part or parts found to be defective by ZF Marine Arco S.p.A. upon its examination of same, provided that the part or parts are returned to the nearest official ZF Marine Arco S.p.A. distributor, freight prepaid, within the time:

1. Transmission for pleasure craft...  
Twenty-four (24) months from date of commissioning or thirty-six (36) months from date of delivery to engine manufacturer, whichever occurs first.
2. Transmission for commercial craft...  
Twelve (12) months from date of commission or twenty-four (24) months from date of delivery to engine manufacturer, whichever occurs first.

The obligations of ZF Marine Arco S.p.A. under this warranty as set forth herein shall also be subject to compliance by the distributor or engine manufacturer who has purchased the product with the Warranty Procedures which is made a part of this warranty. All warranties shall run to distributors and engine manufacturers who have purchased the type ZFM Reversing Marine Transmission. This warranty shall not apply to any part or parts which have been repaired or altered, without the prior written consent of an official ZF Marine Arco S.p.A. dealer. This warranty shall not apply if the product or any of its components or parts have been subject to misuse, abuse, negligence, alteration, or accident, or have not been operated in accordance with printed instructions of ZF Marine Arco S.p.A. or has been operated under conditions more severe than, or otherwise exceeding, those set forth in the specifications for said product, or has been improperly installed or reinstalled, or improperly maintained and operated. This warranty is expressly in lieu of all other warranties expresses or implied including the warranties of merchantability and fitness for use and of all other obligations including without limitation, consequential damages, and ZF Marine Arco S.p.A. neither assumes nor authorizes any other person to assume for ZF Marine Arco S.p.A., any other liability in connection with the sale of the ZFM REVERSING MARINE TRANSMISSION. ZF Marine Arco S.p.A. shall in no event be liable for any breach of warranty in an amount exceeding the purchase price of the ZFM REVERSING MARINE TRANSMISSION.

<b>Transmission model</b> <b>Ratio                      Serial No.</b>	<b>Owner</b> .....  
<b>Engine make and type</b>	<b>Address</b> .....  
<b>Engine Rating</b> <b>hp                                  at                                  rpm</b>	<b>Country</b> .....  
<b>Date of Commissioning</b>	 
<b>Shifting Lever Position</b> <input type="checkbox"/> <b>A</b> <b>For Forward</b> <input type="checkbox"/> <b>B</b>	 
<b>Pleasure Craft</b> <input type="checkbox"/> <b>Commercial Craft</b> <input type="checkbox"/>	<b>Signature</b> .....  

%

%

To be returned duly signed to ZF Marine Arco S.p.A. (TN) - Italy  
 Da ritornare alla ZF Marine Arco S.p.A. (TN) dopo averlo completato con i vostri dati e quelli relativi all'investitore.  
 A renvoyer au ZF Marine Arco S.p.A. (TN) - Italy - apres l'avoir rempli  
 Ausgefüllt an ZF Marine Arco S.p.A. (TN) - Italy - zurück

<b>Transmission model</b> <b>Ratio                      Serial No.</b>	<b>Owner</b> .....  
<b>Engine make and type</b>	<b>Address</b> .....  
<b>Engine Rating</b> <b>hp                                  at                                  rpm</b>	<b>Country</b> .....  
<b>Date of Commissioning</b>	 
<b>Shifting Lever Position</b> <input type="checkbox"/> <b>A</b> <b>For Forward</b> <input type="checkbox"/> <b>B</b>	 
<b>Pleasure Craft</b> <input type="checkbox"/> <b>Commercial Craft</b> <input type="checkbox"/>	<b>Signature</b> .....  





**PROGRAMMA DI MANUTENZIONE - MAINTENANCE PROGRAM - WARTUNGSPLAN  
PROGRAMME D'ENTRETIEN - PROGRAMA DE MANTENIMIENTO - VEDLIKEHOLDSPLAN -  
PROGRAMA DE MANUTENÇÃO - ONDERHOUDSPROGRAMMA - HUOLTO- OHJELMA -  
ΠΡΟΓΡΑΜΜΑ ΣΥΝΤΗΡΗΣΗΣ - PROGRAM ODRŽAVANJA**

**INTERVENTO - INTERVENTION - LEISTUNG - INTERVENTION  
- INTERVENCIONES - INNGREP - INTERVENÇÃO - INGREEP -  
TOIMENPITEET - ΠΕΡΙΓΡΑΦΗ ΕΡΓΑΣΙΩΝ - ZAHVAT**

Descrizione - Description - Beschreibung - Description - Descripción - Beskrivelse  
- Descrição - Beschrijving - Kuvaus - Περιγραφή - Opis

.....  
.....  
.....  
.....  
.....

Timbro officina Data / Workshop stamp - Date /  
Werkstattstempel - Datum / Tampon de l'Atelier - Date /  
Sello taller - Fecha / Verkstedstempel - dato /  
Carimbo da oficina - Data / Stempel werkplaats Datum /  
Korjaamon leima- Pvm / Σφραγίδα Συνεργείου & Ημερομηνία  
- Pečat servisera Datum

**INTERVENTO dopo prime 25 ore - INTERVENTION After the first 25  
hours - LEISTUNG erste 25 Stunden - INTERVENTION après pre-  
mière 25 heures - INTERVENCION después de las primeras 25 horas  
- INGREEP etter de første 25 timene - INTERVENÇÃO Depois das  
primeiras 25 horas - INGREEP na de eerste 25 uren - Toimenpiteet  
25 käyttötunnin jälkeen - Εργασία Συντήρησης μετς πρώτες 25 ώρες  
λειτουργίας - ZAHVAT nakon prvih 25 sati rada**

Sostituzione olio - Fluid change - Ölwechsel - Vidange de l'huile - Sustitución  
aceite - Oljeskift - Troca de fluido - Olie vervangen - Öljynvaihto -

Αλλαγή Λαδιού - Zamjena ulja - .....

Sostituzione filtro olio - Filter fluid change - Filterwechsel - Vidange de  
filtre huile - Sustitución filtro aceite - Skifte oljefilter - Substituição de  
filtro - Oliefilter vervangen - Suodattimen vaihto -

Αντικατάσταση φίλτρου - Filter ulja - .....

Timbro officina Data / Workshop stamp - Date /  
Werkstattstempel - Datum / Tampon de l'Atelier - Date / Sello  
taller - Fecha / Verkstedstempel - dato /  
Carimbo da oficina - Data / Stempel werkplaats Datum /  
Korjaamon leima- Pvm / Σφραγίδα Συνεργείου & Ημερομηνία  
- Pečat servisera Datum

**INTERVENTO - INTERVENTION - LEISTUNG - INTERVENTION  
- INTERVENCIONES - INNGREP - INTERVENÇÃO - INGREEP -  
TOIMENPITEET - ΕΡΓΑΣΙΕΣ ΣΥΝΤΗΡΣΗΣ - ZAHVAT**

Descrizione - Description - Beschreibung - Description - Descripción - Beskrivelse  
- Descrição - Beschrijving - Kuvaus - Περιγραφή - Opis

.....  
.....  
.....

Timbro officina Data / Workshop stamp - Date /  
Werkstattstempel - Datum / Tampon de l'Atelier - Date / Sello  
taller - Fecha / Verkstedstempel - dato /  
Carimbo da oficina - Data / Stempel werkplaats Datum /  
Korjaamon leima- Pvm / Σφραγίδα Συνεργείου & Ημερομηνία  
- Pečat servisera Datum









**Marine Propulsion Systems**

**ZF Marine GmbH**  
Ehlerstr. 50  
D-88046 Friedrichshafen  
GERMANY  
Phone +49 (0) 7541 77-2207  
Fax +49 (0) 7541 77-4222  
E-mail: info.zfmarine@zf.com

**ZF Padova S.p.A.**  
Via Penghe, 48  
I-35030 Caselle di Selvazzano  
(Padova) ITALY  
Phone (+39) 049 8299-311  
Fax (+39) 049 8299-550  
E-mail: info.zfpadova@zf.com

**ZF Marine Arco S.p.A.**  
Via S. Andrea, 16  
I-38062 Arco  
(Trento) ITALY  
Phone (+39) 0464 580-555  
Fax (+39) 0464 580-544  
E-mail: info.zfhurth@zf.com

**ZF do BRASIL Ltda**  
Avenida conde Zeppelin 1935  
Cep. 18103-905  
Sorocaba - SP - BRASIL  
Phone +55 (0) 15 4009 2389  
Fax +55 (0) 15 4009 2233  
E-mail: marine.info@zf-group.com.br

Plus d'informations sur : [www.dbmoteurs.fr](http://www.dbmoteurs.fr)