

OPERATOR'S MANUAL

D34 Marine Genset

CALIFORNIA

Proposition 65 Warning

Diesel engine exhaust and some of its constituents are known to the State of California to cause cancer, birth defects, and other reproductive harm.

Plus d'informations sur : www.dbmoteurs.fr

Foreword

Thank you for purchasing this Volvo Penta Marine Genset.

The Operator's Manual contains operation instructions and maintenance and inspection information. In order to ensure safety and bring out the maximum performance of the genset, do not operate it until you have read and fully understood the contents of this manual. Also do not operate the genset unless in compliance with local regulations.

For information on generator specific items refer to generator information supplied by generator manufacturer. In case of contradictions, the information in this Volvo Penta Operator's Manual overrules any information given in the documentation provided by the generator manufacturer. Do not hesitate to consult your Volvo Penta dealer.

Failure to follow the instructions and cautions in this manual may result in serious accidents.

* Keep this manual at hand for easy reference.

* If this manual is damaged or misplaced, immediately order a new one from your dealer.

All information and illustrations in this manual are based on the specifications that were available at the time of printing. This manual does not cover all available variants of accessories and options.

Contents

Safety Information	5	Cooling system, general	59
Safety regulations during engine operation	6	Cooling system D34 MS HE	60
Safety directions for maintenance and service	7	Cooling system D34A MS RC	61
Warning labels	10	Cooling system D34A MS KC	62
Introduction	12	Cooling system D34A MT HE	63
Certified engines	13	Cooling system D34A MT KC	64
Warranty	13	Freshwater system	65
Presentation	14	Coolant mixture	66
New genset initial service	19	Checking the coolant level	67
Starting	20	Filling the coolant	67
Classifiable control system	22	Draining the coolant	69
LCD screen	23	Flushing the freshwater system	69
Views	24	External cleaning of charge air cooler	70
Starting the genset	26	Rawwater system	71
Operation	27	Draining the rawwater system	71
Stopping the genset	28	Checking and changing the zinc anodes	71
Operation	29	Checking and changing rawwater filter	71
Stopping	30	Checking and changing rawwater pump impeller ..	72
Manual stop lever	30	Cleaning heat exchanger	72
After stopping	30	Electrical system	73
Anti-freezing measures	31	Electric welding	73
Breaks in operation	31	Batteries	74
Maintenance	32	Control system	76
Maintenance schedules	33	System overview	76
Recommendation of Daily Operation Records	39	A/D converter	77
Engine	40	Shutdown unit (SDU)	81
Valve clearance	40	Broken wire	82
Turning the engine	42	Overspeed shutdown test	82
Vibration damper inspection	42	Inhibiting	83
Lubrication system	43	Troubleshooting	85
Checking oil level	43	Technical Data	86
Filling oil	43	D34A MS	86
Changing oil	44	D34A MT	87
Changing oil filters	45	Fuel specification	88
Fuel system	47	Lubrication oil specification	89
Bleeding the fuel system	47	Coolant specification	90
Changing the fuel filter	49	Tightening torque table	91
Changing the fuel injector nozzle	50	Identification numbers	97
Fuel injection pressure	51	Notes	98
Injection timing inspection	53		
Twin fuel pre-filter/water separator	55		
Air inlet and exhaust systems	57		
Turbocharger inspection	57		
Cleaning the air cooler	57		
Washing the air inlet silencer filter	58		

Safety Information

Read this chapter thoroughly. It concerns your safety. This section describes how safety information is presented in this manual and on the product. It also includes a summary of basic safety regulations for operation and maintenance of the engine.

This Operator's Manual is only valid for complete gensets built in the Volvo Penta factory. Make sure you are in possession of the right operator's manual before reading on. If this is not the case, please get in touch with your Volvo Penta dealer.

If operations are performed incorrectly it could result in personal injury or damage to property or the engine. Read the Operator's Manual carefully before operating or servicing the engine. For safety information on operation and maintenance of the generator, refer to the generator documentation.

If anything is unclear please contact your Volvo Penta dealer for assistance.



 This symbol is used in the book and on the engine to make you aware of safety information. Always read these safety precautions very carefully.

In the Operator's Manual warning texts have the following priority:

 **WARNING!** If these instructions are not followed there is a danger of personal injury, extensive damage to the product or serious mechanical malfunction.

 **IMPORTANT!** Used to draw your attention to something that can cause damage, product malfunction or damage to property.

NOTE! Used to draw your attention to important information that will facilitate work or operations.

 This symbol is used in certain cases on our products and refers to important information in the Operator's Manual. Ensure that warning and information symbols on the engine and transmission are always visible and legible. Replace symbols that have been damaged or painted over.

Safety regulations during engine operation

The new engine

Read instruction manuals and other information accompanying the new vessel thoroughly. Accustom yourself with handling the engine, controls and other equipment in a safe and correct manner.

Remember that when operating a vessel, you have a legal responsibility to be aware of and follow regulations concerning traffic and safety at sea. Inform yourself of the regulations applicable to your vessel and the waters you are in by getting in touch with the relevant authorities or marine safety organization.

Accidents and other incidents

Sea rescue statistics show that deficient maintenance of vessels and engines together with defective safety equipment often causes accidents and other incidents at sea.

Make sure your vessel and engine are maintained in accordance with directions in the instruction manuals and that the safety equipment on board is in good working order.

Daily inspection

Make a habit of visually inspecting the engine and engine room before starting and after stopping the engine. This will help you to quickly detect any fuel, coolant or oil leaks and any other abnormalities that have occurred or are about to occur.

⚠ WARNING! Accumulations of fuel, oil and grease on the engine or in the engine room is a fire hazard and must be removed immediately they are detected.

⚠ IMPORTANT! If an oil, fuel or coolant leak is detected, the cause must be investigated and the fault rectified before the engine is started.

Maneuvering

Avoid violent and rapid rudder movement and gear shifting. There is a risk of the passengers falling down or falling overboard. A rotating propeller can cause serious injury. Make sure there is nobody in the water before engaging forward/reverse. Never run close to bathers or in places where you have reason to believe there are people in the water.

Filling fuel

There is a risk of fire and explosion when filling fuel. Smoking is prohibited and the engine must be turned off. Never overfill the tank. Close the filler cap securely. Use only fuel recommended in the operators manual. The incorrect grade of fuel can disturb operation or cause breakdown. This can also lead to the control rod jamming on diesel engines, which will cause the engine to overspeed and risk damaging machinery and causing personal injury.

Combustible environment

Due to the risk of fire and/or explosion, do not start or continue to run the engine if there is a suspected leak or discharge of combustible media, e.g. fuel oil or LPG, in the engine surroundings.

Carbon monoxide poisoning

When a vessel is moving forward, it will cause a certain vacuum to form behind the vessel. In unfortunate circumstances, the suction from this vacuum can be so great that the exhaust gases from the vessel are drawn into the bridge or cabin and cause carbon monoxide poisoning. This problem is most prevalent on high, wide vessels with abrupt stern. Other factors that can increase the effect of the suction are wind conditions, load distribution, swells, trim, open hatches and portholes, etc. Most modern vessels, however, are designed in such a way that this problem is very rare. If suction should arise anyway, do not open hatches or portholes at the fore of the vessel. Surprisingly, this will otherwise increase the suction. Try changing speed, trim, or load distribution instead. Get in touch with your Volvo Penta dealer for help in obtaining the best solution for your vessel.

Safety directions for maintenance and service

⚠ Preparations

Knowledge

The operator's manual contains directions for performing normal maintenance and service in a safe and correct manner. Read the directions carefully before starting work. More detailed service literature is available from your Volvo Penta dealer. Never perform a task unless you are absolutely sure how it is to be carried out; call your Volvo Penta dealer for assistance instead.

Stop the engine

Stop the engine before opening or dismantling the engine hatch/hood. Maintenance and service must be carried out with the engine stationary unless stated otherwise in the instructions. Prevent inadvertent start of the engine by removing the starter key and turning off the power with the main switch, locking it in the off position. Place warning signs stating that service is in progress in every position from which the engine can be started. Working on or approaching a running engine is a safety hazard. Loose clothing, hair, fingers or a dropped tool can be caught in rotating parts and cause serious bodily injury. Volvo Penta recommend leaving all work requiring the engine to be running to an authorized Volvo Penta dealer.

Lifting the engine

Always use the lifting eyes mounted on the engine when lifting the engine. Always make sure lifting equipment is in good condition and constructed for the lift (engine weight together with possible reverse gear and extra equipment). Use an adjustable lifting boom to ensure safe handling when lifting the engine. All chains and wires must run parallel with each other and as much at right angle as possible to the top of the engine. Note that any extra equipment mounted on the engine can change the center of gravity. Special lifting devices may be required to obtain the right balance and safe handling. Never perform service on an engine suspended only from a lifting device.

⚠ **IMPORTANT!** Engine must only be lifted horizontally.

⚠ **IMPORTANT!** Engine lifting eyes are designed only for lifting an engine. Do not use the engine lifting eyes when lifting a complete genset.

Before starting

Refit all guards and covers that have been removed before starting the engine. Make sure there are no tools or other objects left on the engine. A turbocharged engine must never be started without the air filter fitted. The rotating compressor wheel in the turbocharger can cause severe personal injury.

There is also a risk of foreign objects being drawn in and causing mechanical damage.

⚠ Fire and explosion

Fuel and lubricants

All fuels, most lubricants, and many chemicals are flammable substances. Always read and follow the directions on the packaging. Work performed on the fuel system must be done on a cold engine. Fuel leaks and spills on hot surfaces or electrical components can cause fires.

Keep oil- and fuel drenched rags and other hazardous materials where they are safe in case of fire. Oil drenched rags can selfignite in certain conditions. Never smoke when refueling, topping up with oil or when in the vicinity of the fuel station or the engine room.

Non-original parts

Components in fuel, lubrication, ignition and electrical systems on Volvo Penta engines are designed and manufactured to minimize the risk of explosion and fire in compliance with existing legislation.

The use of non-original parts can result in explosion or fire.

Batteries

Batteries contain and generate oxyhydrogen gas, especially when charging. Oxyhydrogen is easily ignited and extremely explosive. Smoking, open flames and sparks must never occur in, or close to, the batteries or battery compartment. A faulty battery connection or jumper cable can generate sparks that can cause the battery to explode.

Start spray

Never use start spray or similar start help. Explosions can occur in the intake manifold. Risk for personal injury.

⚠ Hot surfaces and fluids

At operating temperature, the engine and its components are hot. A hot engine always involves risk for burn injuries. Take care with hot surfaces. E.g.: exhaust manifold, turbocharger, oil pan, charge air pipe, starting heater, hot coolant and warm lubricant in pipes and hoses.

⚠ WARNING! Do not open the crankcase covers while the engine is still hot.

⚠ Carbon monoxide poisoning

Start the engine in well-ventilated spaces only. When running in confined spaces, the exhaust gases and crankcase gases must be evacuated.

⚠ Chemicals

Most chemicals such as glycol, anti-corrosion agent, preservatives, degreasing agent, etc., are hazardous to health. Always read and follow the directions on the packaging.

Certain chemicals such as preservatives are flammable and harmful to inhale. Provide good ventilation and use breathing protection when spraying. Always read and follow the directions on the packaging. Store chemicals and other hazardous materials out of reach of children. Leave left over or used chemicals to a destruction plant.

⚠ Cooling system

There is a risk of water entering when working on the seawater system. Therefore, stop the engine and close the seawater cock before starting work.

Avoid opening the coolant filler cap when the engine is warm. Steam or hot coolant may spurt out and cause burn injuries.

If the filler cap, coolant pipe, cock, etc., must nevertheless be opened or dismantled while the engine is warm, the filler cap must be opened carefully to release the pressure before removing it completely and starting work. Note that the coolant can still be hot and cause burn injuries.

⚠ Lubricating system

Hot oil can cause burn injuries. Avoid skin contact with warm oil. Make sure the lubricating system is depressurized before starting work. Never start or run the engine with the oil filler cap removed or there will be a risk of the oil being thrown out.

⚠ Fuel system

Always protect your hands when carrying out leak detection.

Escaping fluids under pressure can pierce bodily tissue and cause serious injury. Risk of blood poisoning. Always cover any electric component if it is located under the fuel filter. Otherwise it might be damaged by fuel spills.

⚠ Electrical system

Turn off the power before commencing work on the electrical system, the engine must be stopped and the powered turned off with the main switch/switches. Shore power to the engine heater, battery charger or other extra equipment fitted to the engine must be disconnected.

Batteries

Batteries contain a highly corrosive electrolyte. Protect your eyes, skin and clothing when charging and handling batteries. Always use protective goggles and gloves.

In case of splashes on the skin, wash with soap and plenty of water. In case of splashes in the eyes, rinse immediately with plenty of water and call a doctor.

Avoid burns and crushing or cutting!

At operating temperature, the engine coolant is hot and under pressure. Steam can cause personal injury. Check the coolant level only after the engine has been stopped and the coolant filler cap has cooled enough to touch with your hand. Never adjust the V-belts while the engine is running.

Service batteries carefully!

If you spill electrolyte on yourself, flush skin immediately with lots of water. Apply baking soda to help neutralize the acid. If electrolyte gets in your eyes, rinse immediately with large amounts of water then contact a doctor at once.

Handle antifreeze carefully!

Antifreeze contains alkali. Avoid contact with skin and eyes to prevent personal injury. Dispose of drained antifreeze coolant according to local regulations. For disposal, consult your dealer.

Dress properly for the job!

Wear protective devices - hard hat, face shield, safety shoes, goggles, heavy gloves, ear protectors, etc. - for your own safety.

Recommended fuel, lubrication oil and coolant!

Use of any other fuel oil, lubrication oil or coolant than the recommended can cause engine damage and reduce engine service life.

Perform all recommended inspections!

Perform pre-start inspection and periodic inspection on items listed in this manual. Failure to follow this recommendation can cause serious engine damage.

Warning labels

D34A MS

The engine carries 'Warning Labels' at places where you are required to pay special attention. Please read them carefully and make sure you understand the content of each label and the meaning of their position.

1. Make sure the labels are legible. If you find any letter or picture illegible in a label, remove soil from the label, or replace it.
2. Clean the label with cloth and water or cleanser. Do not use organic solvent or gasoline, this would dissolve the label's adhesive and cause the label to fall off.
3. If any label is damaged, lost or illegible, replace it. When replacing a label, make sure the new label is identical to the old one. For new labels, please contact your dealer.

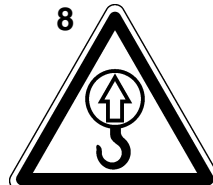
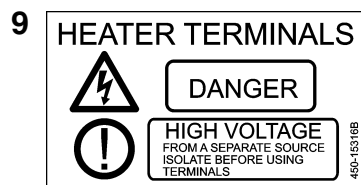
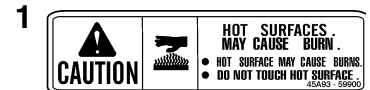
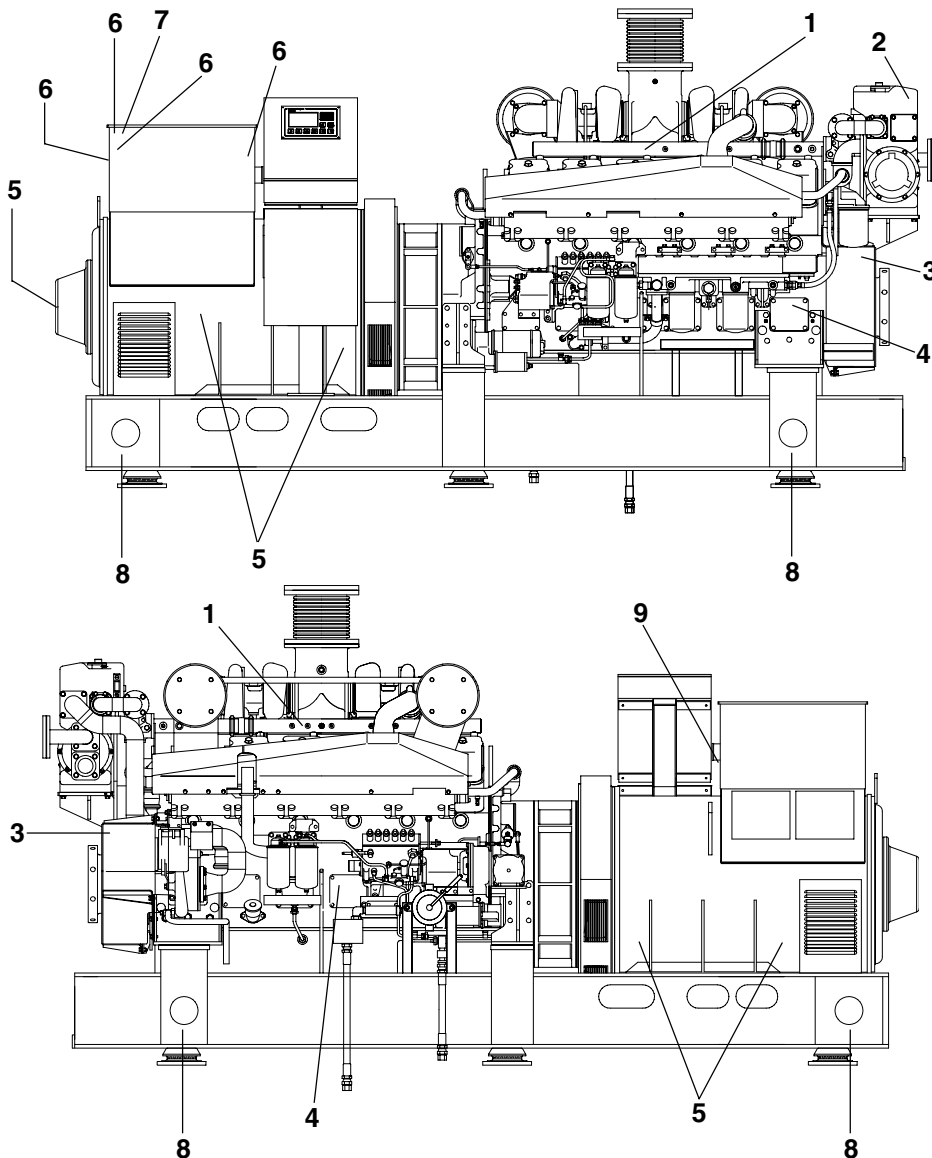

D34A MT

The engine carries 'Warning Labels' at places where you are required to pay special attention. Please read them carefully and make sure you understand the content of each label and the meaning of their position.

1. Make sure the labels are legible. If you find any letter or picture illegible in a label, remove soil from the label, or replace it.
2. Clean the label with cloth and water or cleanser. Do not use organic solvent or gasoline, this would dissolve the label's adhesive and cause the label to fall off.
3. If any label is damaged, lost or illegible, replace it. When replacing a label, make sure the new label is identical to the old one. For new labels, please contact your dealer.

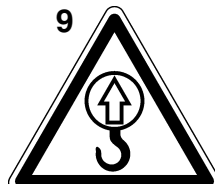
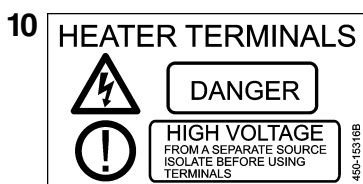
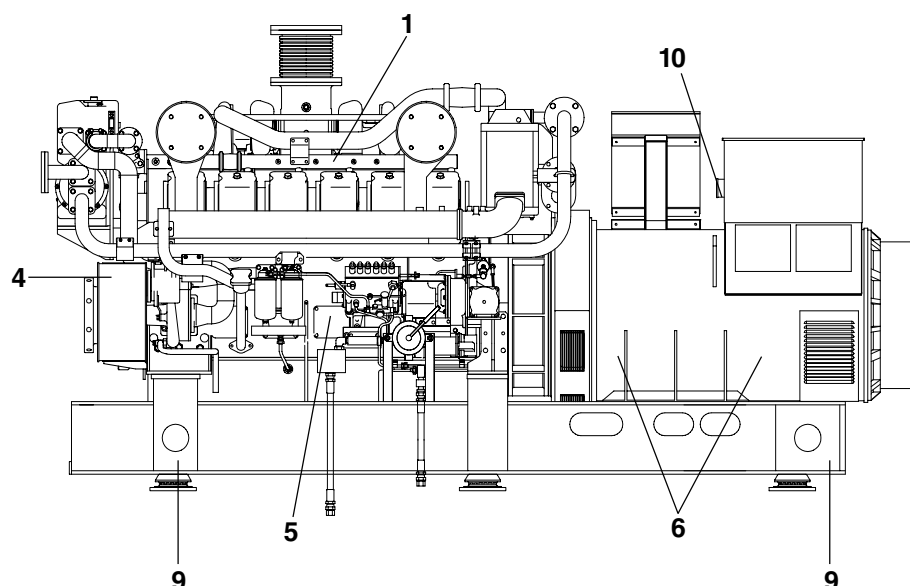
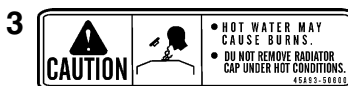
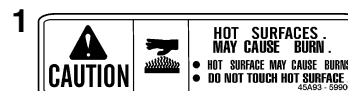
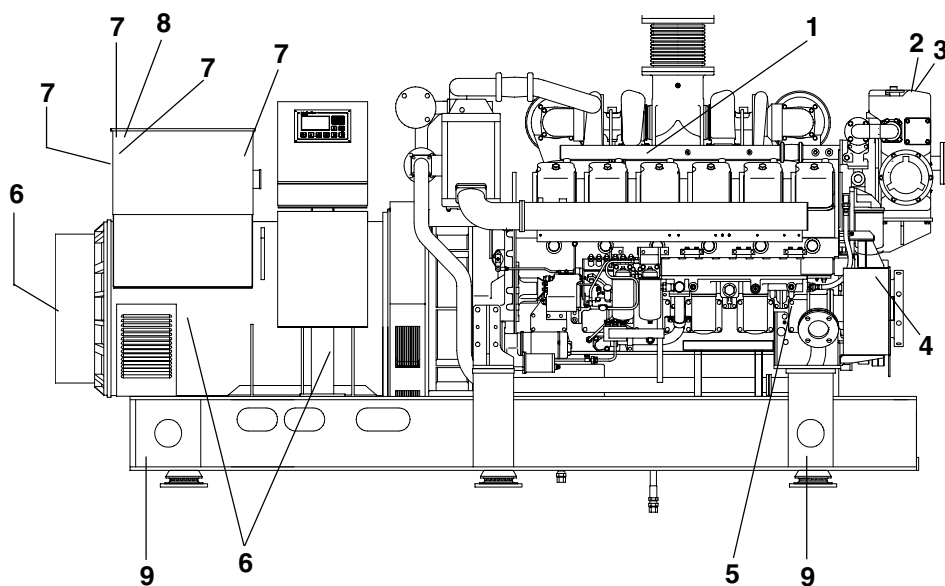

Introduction

This operator's manual has been produced to give you the greatest benefit of your Volvo Penta Marine Genset. It contains the information necessary to handle and maintain your genset in a safe and correct manner. We would like you to read this operator's manual thoroughly and learn how to handle the genset, controls and other equipment in a safe manner before operating the genset.

Keep the operator's manual within reach at all times.

Care of the environment

We would all like to live in a clean and healthy environment. An environment where we can breathe clean air, see healthy trees, have clean water in our lakes and oceans, and enjoy the sunshine without being worried about our health. Unfortunately, this cannot be taken for granted nowadays but it is something we must work together to achieve.

As a manufacturer of marine engines Volvo Penta has a special responsibility. That is why care of the environment is a core value in our product development. Volvo Penta has a broad range of engines where progress has been made in reducing exhaust emissions, fuel consumption, engine noise, etc. We hope you will take part in preserving these qualities.

Always follow any advice given in the operator's manual concerning fuel grades, operation and maintenance and you will avoid causing unnecessary interference to the environment. Get in touch with your Volvo Penta dealer if you notice any changes such as increased fuel consumption and/or exhaust smoke.

Adapt speed and distance to avoid wash and noise disturbing or injuring animal life, moored boats, jetties, etc. Leave islands and harbours in the same condition as you want to find them. Remember to always leave hazardous waste such as waste oil, coolant, paint and wash residue, flat batteries, etc., for disposal at a destruction plant. Our joint efforts will make a valuable contribution to our environment.

Fuel and oil

Use only fuel and lubrication oil grades recommended in the technical data section of this Operator's Manual. Other grades can cause operational problems, increase fuel consumption and have long-range effects on engine service life.

Service and spare parts

Volvo Penta marine engines are designed for high operational reliability and long service life. They are constructed to withstand the marine environment while affecting it as little as possible. Through regular service and the use of Volvo Penta original spare parts, these qualities will be retained.

The worldwide Volvo Penta network of authorized dealers is at your service. They are specialists in Volvo Penta products and stock accessories, original spare parts, test equipment and the special tools required to perform high-quality service and repairs.

Always follow the maintenance intervals specified in the operator's manual and remember to specify the engine number when ordering service and spare parts.

Certified engines

It is essential that owners and operators of emission certified engines, used in areas where exhaust emissions are regulated by law, are aware of the following points:

A certification involves the engine type being checked and approved by applicable authorities. Engine manufacturers guarantee that all engines of the same type correspond with the certified engine.

This puts special demands on the maintenance and service of your engine:

- * Maintenance and service intervals recommended by Volvo Penta must be followed.
- * Only Volvo Penta original spare parts may be used.
- * Service of injector pumps, pump settings and injectors must always be performed by an authorized Volvo Penta service person.
- * The engine must not be modified in any way with the exception of accessories and service kits approved by Volvo Penta for use on the engine.
- * Installation modifications must not be made to the engine exhaust pipe or inlet channels.
- * Sealed sections must not be broken by anyone other than authorized personnel.

Otherwise, general directions concerning running, care and maintenance given in the operator's manual apply.

⚠ IMPORTANT! Neglected or deficient maintenance/service and the use of non-original spare parts will entail Volvo Penta renouncing any responsibility for the engine corresponding to the certified version. Volvo Penta will not compensate for damage and/or costs arising from the above.

Warranty

Your new Volvo Penta Marine Genset is covered by a limited warranty complying with the conditions and instructions given in the Warranty and Service Book.

Note that AB Volvo Penta's responsibility is limited to what is specified in the Warranty and Service Book. Read it carefully as soon as possible after delivery. It contains important information concerning the warranty card, service, maintenance and what the owner is responsible to be aware of, check and perform. AB Volvo Penta will otherwise decline warranty liability completely or fully.

Get in touch with your Volvo Penta dealer if you have not received a Warranty and Service Book or a copy of the warranty card.

Presentation

D34A MS HE Marine Genset

The D34A MS HE Marine Genset is a direct injection, 12-cylinder, 4-stroke V-engine. It is equipped with two turbochargers and fitted with a heat exchanger for thermostat-regulated freshwater coolin.

An optimal combination of combustion chambers, fuel injection system, effective turbochargers and charge air cooling, provide excellent fuel consumption over the whole range of power output.

The engine is mounted on a frame with a Stamford single or double bearing marine generator. Different starting and control systems are available.

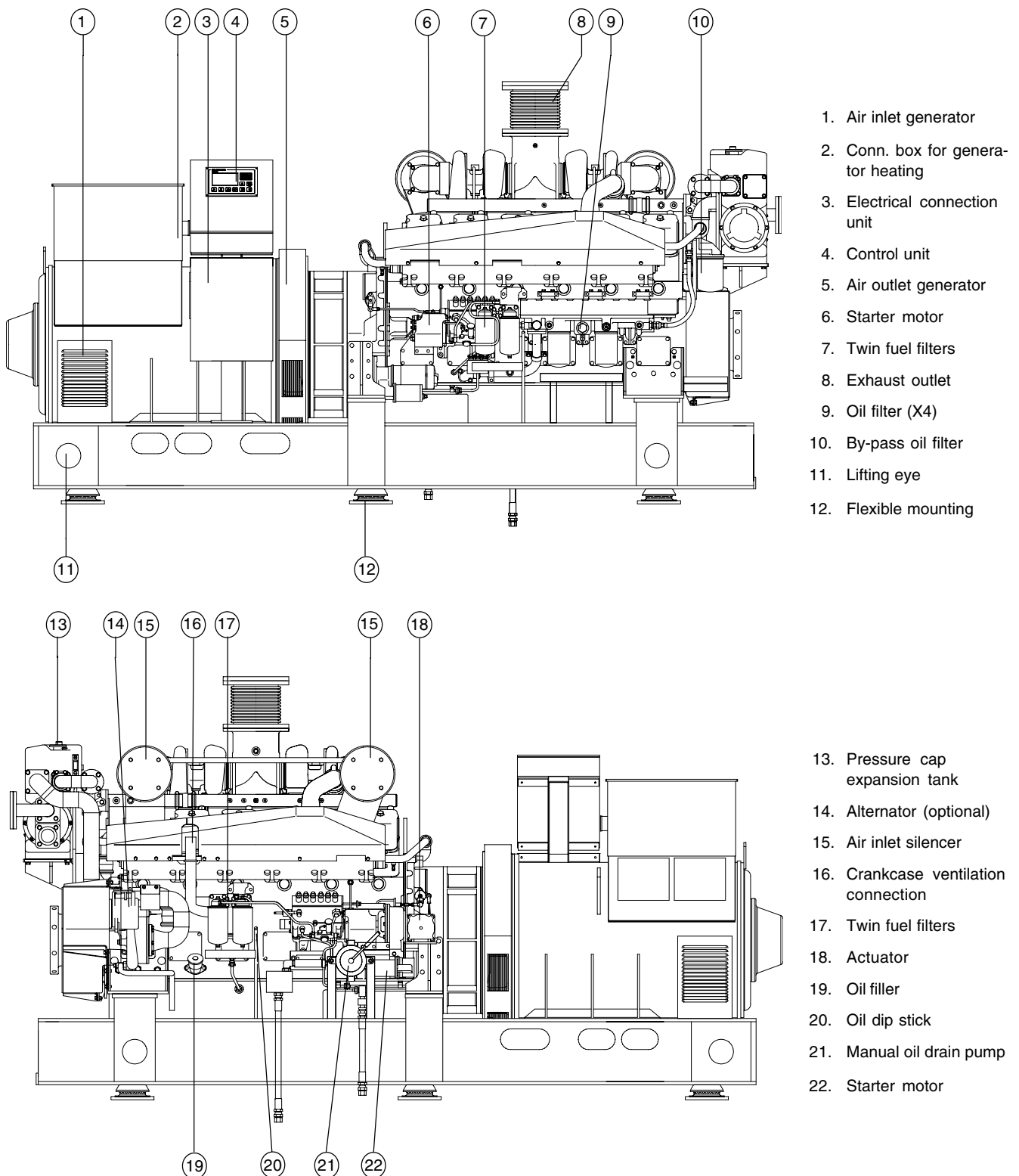

D34A MS RC Marine Genset

The D34A MS RC Marine Genset is a direct injection, 12-cylinder, 4-stroke V-engine. It has two turbochargers and is equipped with radiator cooling.

An optimal combination of combustion chambers, fuel injection system, effective turbochargers and charge air cooling, provide excellent fuel consumption over the whole range of power output.

The engine is mounted on a frame with a Stamford single or double bearing marine generator. Different starting and control systems are available.

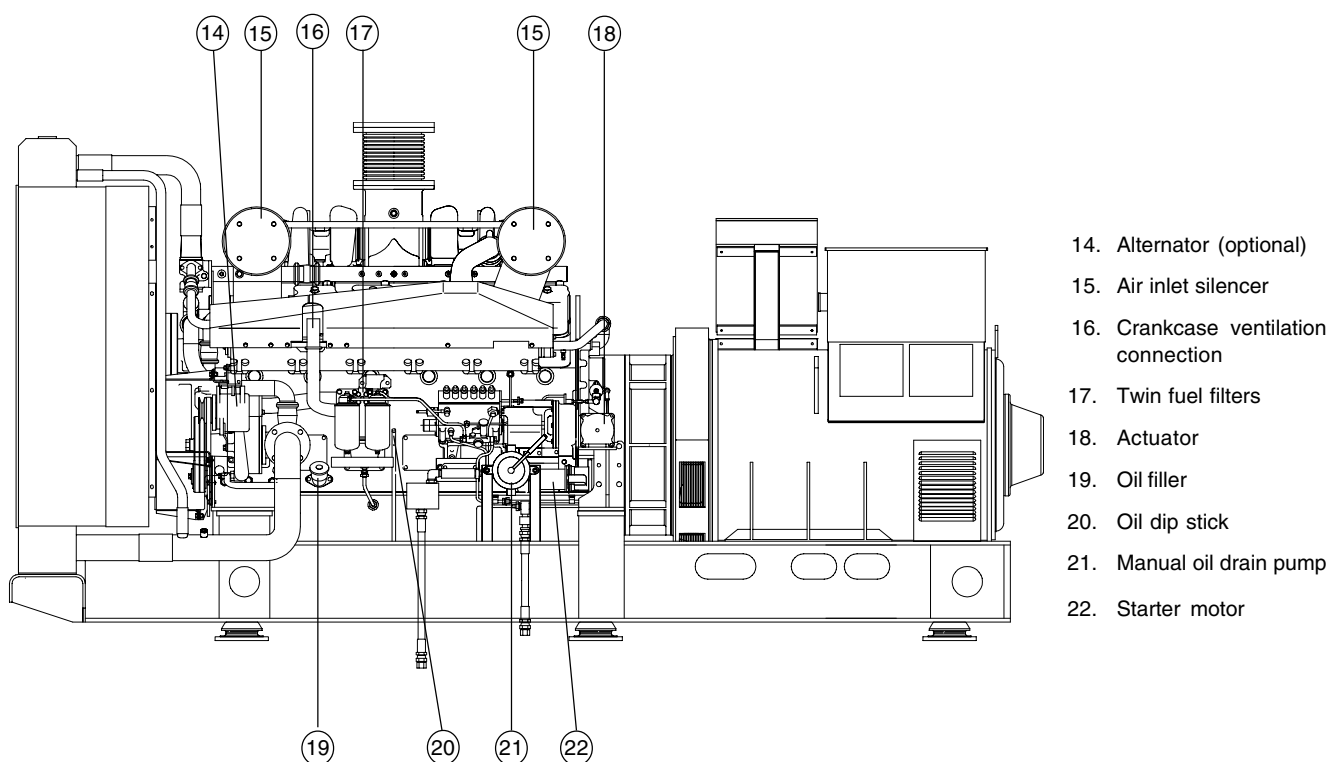
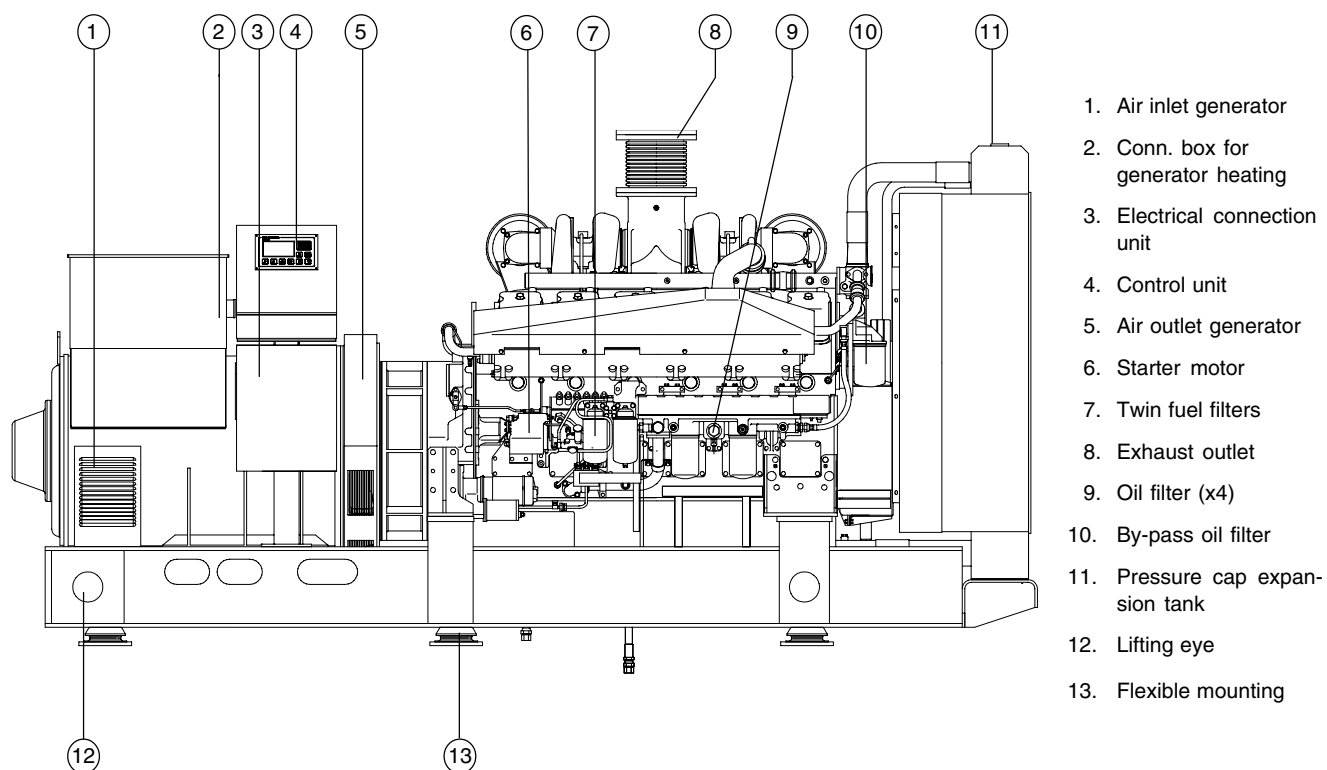

D34A MS KC Marine Genset

D34A MS KC Marine Genset is a direct injection, 12-cylinder, 4-stroke V-engine. It has two turbochargers and is fitted with connections for keel cooling.

An optimal combination of combustion chambers, fuel injection system, effective turbochargers and charge air cooling, provide excellent fuel consumption over the whole range of power output.

The engine is mounted on a frame with a Stamford single or double bearing marine generator. Different starting and control systems are available.

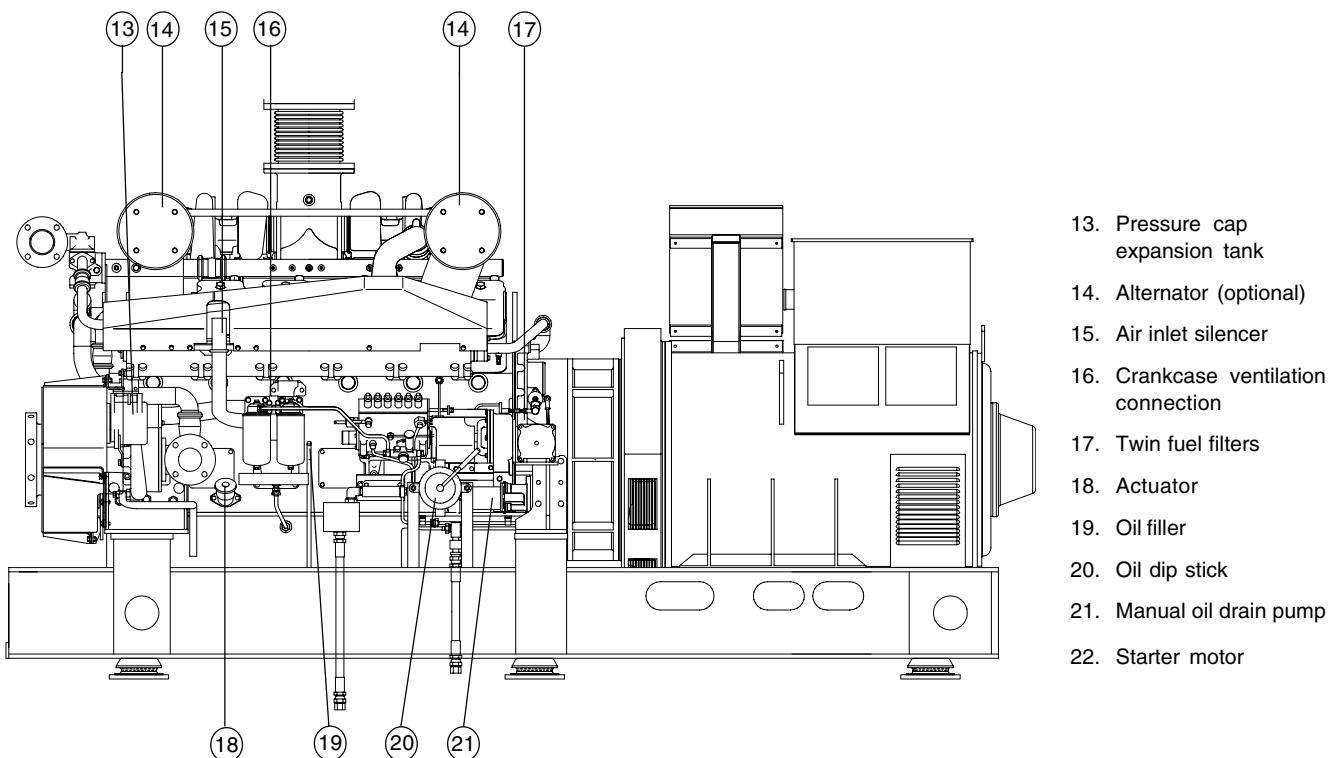
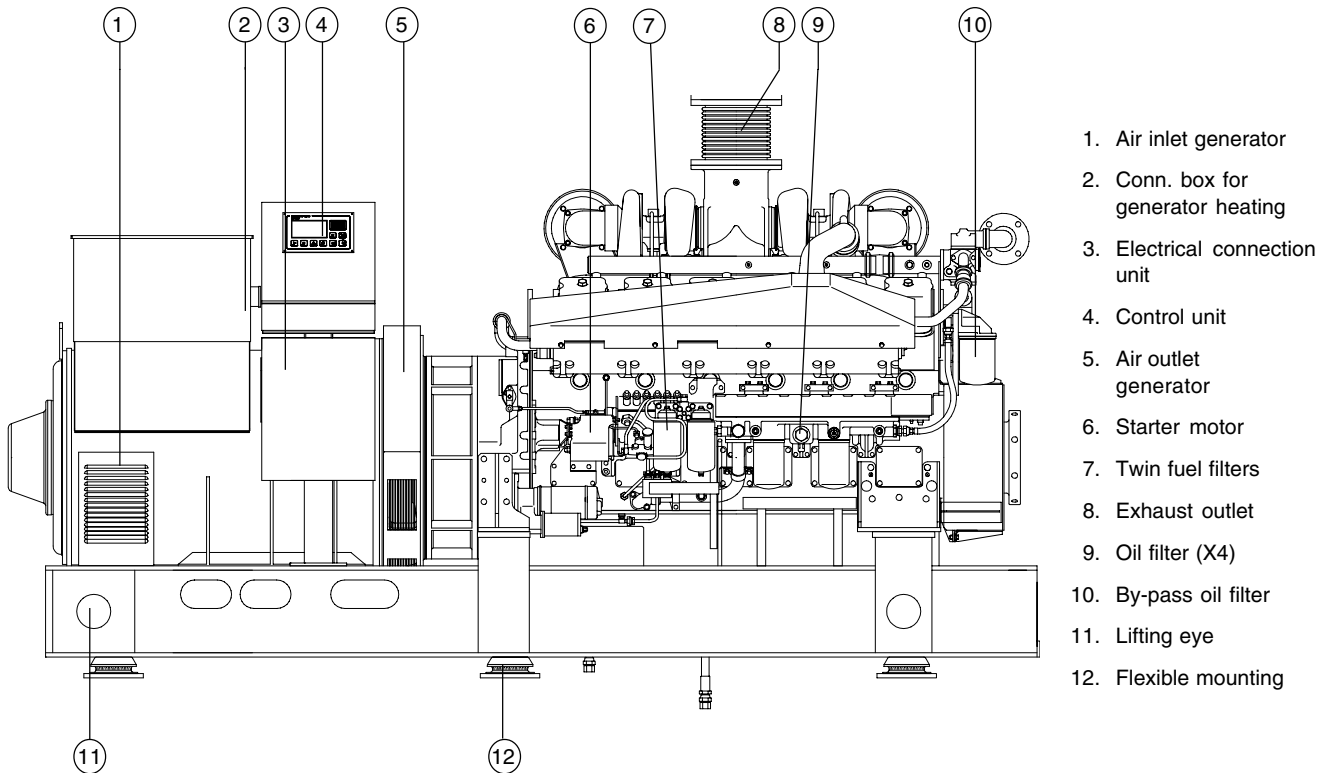

D34A MT HE Marine Genset

The D34A MT HE Marine Genset is a direct injection, 12-cylinder, 4-stroke V-engine. It is equipped with two turbochargers and fitted with a heat exchanger for thermostat-regulated freshwater cooling.

An optimal combination of combustion chambers, fuel injection system, effective turbochargers and charge air cooling, provide excellent fuel consumption over the whole range of power output.

The engine is mounted on a frame with a Stamford single or double bearing marine generator. Different starting and control systems are available.

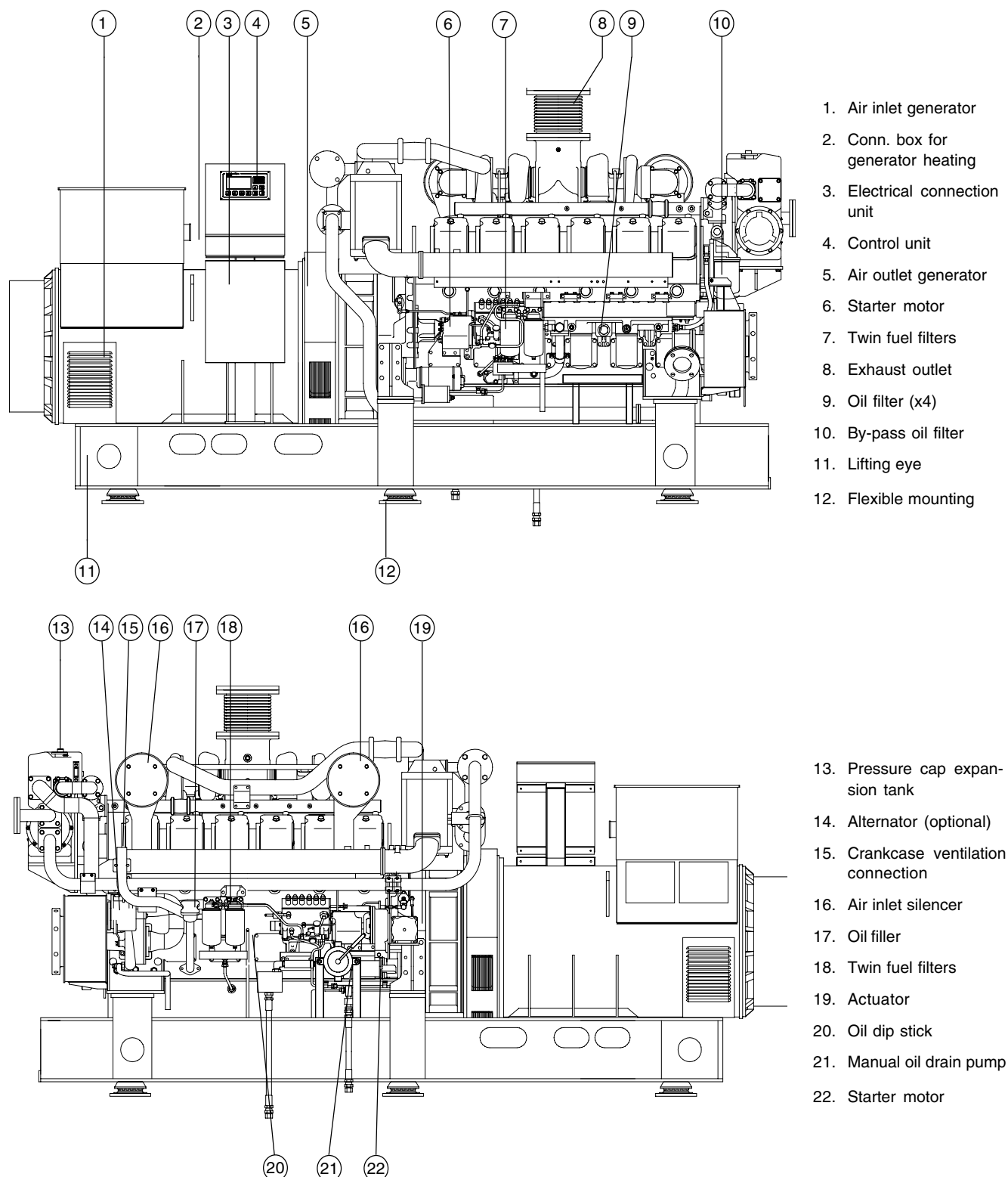

D34A MT KC Marine Genset

D34A MT KC Marine Genset is a direct injection, 12-cylinder, 4-stroke V-engine. It has two turbochargers and is fitted with connections for keel cooling.

An optimal combination of combustion chambers, fuel injection system, effective turbochargers and charge air cooling, provide excellent fuel consumption over the whole range of power output.

The engine is mounted on a frame with a Stamford single or double bearing marine generator. Different starting and control systems are available.

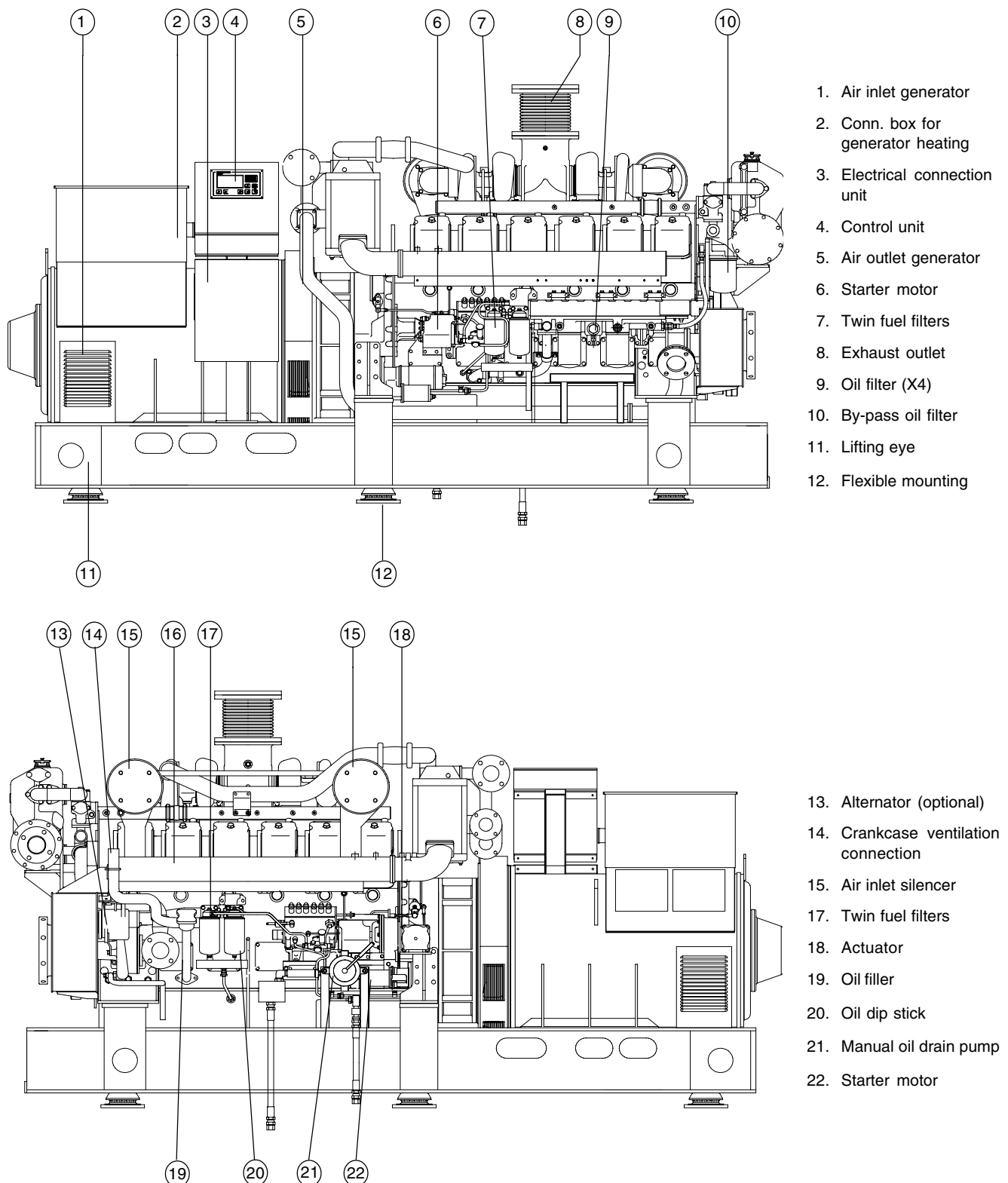

New genset initial service

General

Before starting a new or reconditioned genset for the first time, give it an initial inspection. This to guarantee your own safety as well as the maximum service life of the genset.

External inspection

1. Check the control system for loose terminals.
2. Check defects of engine parts.
3. Check the following components for loose bolts or nuts:
 - * Plugs and covers of fuel, lubrication and cooling system
 - * Coupling of fuel injection pump and shaft
 - * Mounting brackets
 - * Fuel control link
 - * Turbocharger
 - * Timing gear case
 - * Exhaust manifolds
 - * Cylinder heads
 - * Air-duct connection-hose clamp
 - * Flexible coupling from engine to generator
4. Check for fuel, oil, coolant and air leaks and repair if needed.
5. Make commissioning report for new or overhauled engine.

 **IMPORTANT!** All covers on engine and generator must be mounted before attempting to start your genset.

Valves and plugs

Make sure the following valves and plugs are open or closed properly:

Fuel supply valve	Open
Coolant drain cocks	Closed

 **IMPORTANT!** If the coolant drain cocks are not closed the coolant will drain from the engine and this may cause severe damage to the engine.

Electrical wiring

Check for loose or damaged electrical wiring on the engine and on the generator. If necessary firmly re-connect to terminals or cable-joint portions. Damaged cables must be replaced.

If your engine is reconditioned, make sure the wiring is according to the drawings.

Filling fuel system

Refer to chapter "Maintenance: Fuel system".

Filling lubrication system

Refer to chapter "Maintenance: Lubrication system".

Filling cooling system

Refer to chapter "Maintenance: Cooling system".

Generator

Refer to manual supplied by generator manufacturer.

Starting

Before starting

- ⚠ WARNING!** Before starting the genset make sure that neither people, nor tools, are in contact with moving parts of the engine or the generator. Notify the people in the vicinity of the genset when starting.
- ⚠ WARNING!** Make sure that you know how to stop the genset before you start it (in case of emergency). If you are starting the genset for the first time, be prepared to stop the engine immediately in case abnormal noise should occur during start up.
- ⚠ IMPORTANT!** If the starter motor has been engaged for the maximum time (30 seconds), it must be allowed to cool down for at least one minute before a new attempt is made at starting.

Warming-up

- ⚠ WARNING!** Do not conduct warm-up operation for an extended period of time. Prolonged warm-up operation causes carbon buildup in the cylinders that leads to imperfect combustion.

NOTE! To warm up the engine operate at no load for a short time and then apply a low load.

NOTE! If the lubrication oil pressure does not increase when you have started the engine, immediately stop the engine and do not restart until the problem has been fixed.

NOTE! Make sure that the cooling water flow is sufficient.



Start using auxiliary batteries

⚠ WARNING! Ventilate well. Batteries generate oxyhydrogen gas, which is extremely flammable and explosive. A short circuit, naked flame or spark can cause a powerful explosion.

Never reverse the polarity of the battery. Risk of sparks and explosion.

1. Make sure the rated voltage of the auxiliary battery is the same as the system voltage of the engine.
2. Connect the red auxiliary cable to the discharged battery's + terminal and then to the auxiliary battery's + terminal.
3. Connect the black jump lead to the auxiliary battery negative terminal and then to a position slightly away from the discharged batteries, for example at the negative cable's connection to the starter motor.

⚠ WARNING! The black auxiliary cable (–) must not come in contact with the positive connection on the starter motor.

4. Start the engine and run at no load for about ten minutes to charge the batteries.

⚠ WARNING! Do not touch the connections while attempting to start; Risk of sparks. Do not bend over the batteries either.

5. Stop the engine. Remove the auxiliary cables in reverse order to connecting.

Classifiable control system

This chapter describes the functions of the classifiable control system DCU 305 R2. The system control panel is equipped with eight buttons, an LCD screen and four separate LEDs for indication.

NOTE! For specific information on the control system, please refer to documentation supplied by control system manufacturer, Auto-Maskin A/S Norway, or contact your Volvo Penta dealer.

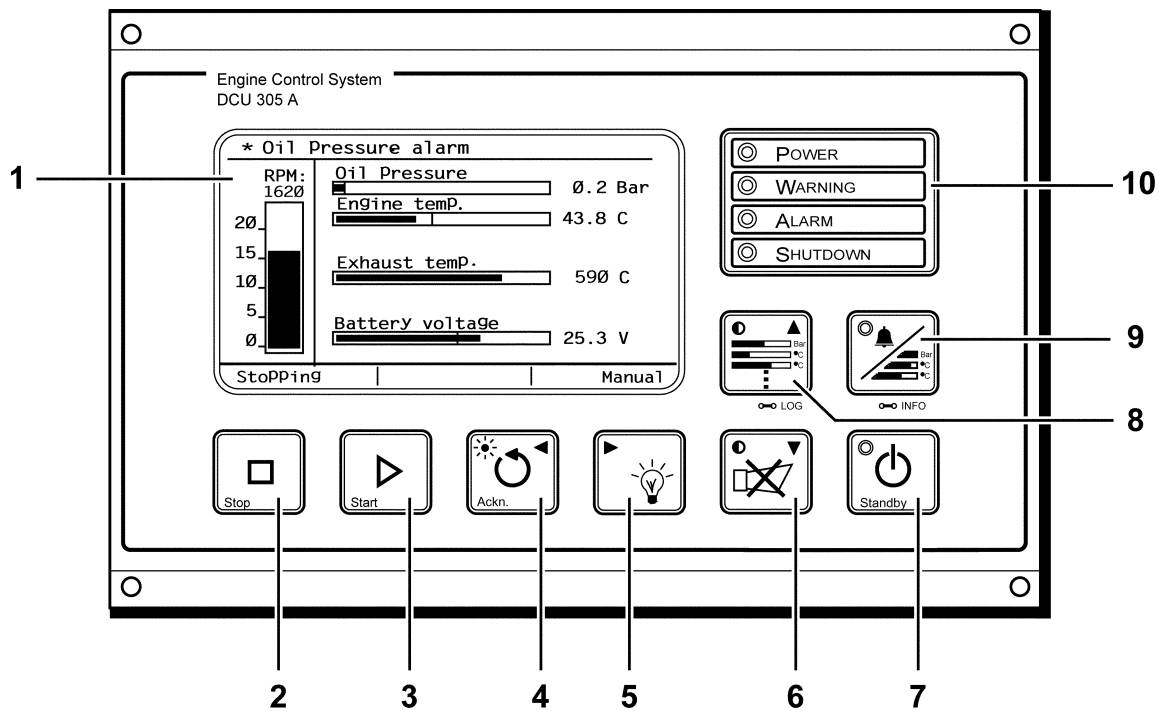

1. LCD screen
2. Stop button
3. Start button
4. Acknowledge button and Left button
5. Lamptest button and Right button
6. Buzzer off button and Down button
7. Standby button
8. Log button and Up button
9. Display button
10. LEDs for indication

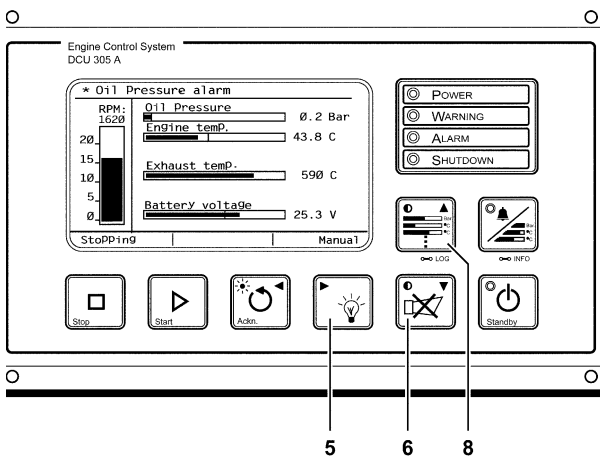

LCD screen

The control unit is equipped with an LCD screen with adjustable brightness and contrast. Analogue signals are displayed graphical, as vertical and horizontal bars, and as digital values. All actions are displayed on the screen as text messages. If the control panel is not used for one hour the screen lighting will be shut down. By any event or button push the display lighting will be turned back on.

Lamp test

To make sure the LEDs on the control panel are working, push the LAMPTEST button (5).

Contrast

Push and hold the LAMPTEST button (5) and adjust the contrast by pushing the DOWN (6) or UP (8) buttons.

Brightness

In the instrument view or the alarm list view, push and hold the LAMPTEST button (5). Adjust the brightness in two steps, 1/1 or 1/2, by pushing the ACKNOWLEDGE button (4).

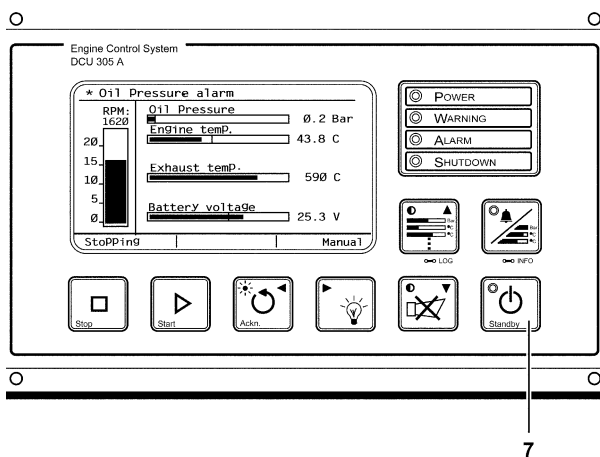
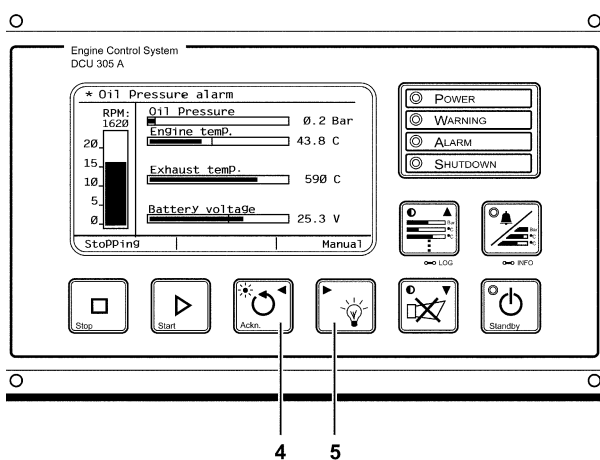

Standby and manual mode

Push the STANDBY button (7) to toggle between Standby and Manual mode. Current mode is shown in the bottom-right corner in the instrument view .

A green LED in the STANDBY button indicates standby mode. If the LED is not lit, the control unit is in Manual mode.

When the control panel is in Standby mode the engine will automatically start when a Start Command signal is received. In Manual mode, automatic start is disabled.

Local mode

It is possible to set the control panel in LOCAL mode. In this mode, none of the start, stop, reset etc. commands will work, neither on communication, nor on terminal inputs.

There are two exceptions, which are the Remote Start (terminal 31) and Remote Stop (terminal 32). This is because the terminals are hardwired directly to the start- and stop relays.

To access LOCAL mode, first enter INFO-view and the press and hold BUZZER OFF for two seconds until a "beep" is heard. The unit is now in LOCAL mode and the bottom right status field will indicate "LOCAL".

To deselect LOCAL mode, repeat the above.

Buzzer off

Push the BUZZER OFF button (6) to turn off the buzzer signal when an alarm occurs. The alarm remains active until acknowledged.

Autostop

Alarms and messages from the control unit are acknowledged by pushing the ACKNOWLEDGE button (4). This must be done to enable restarting the genset after autostop.

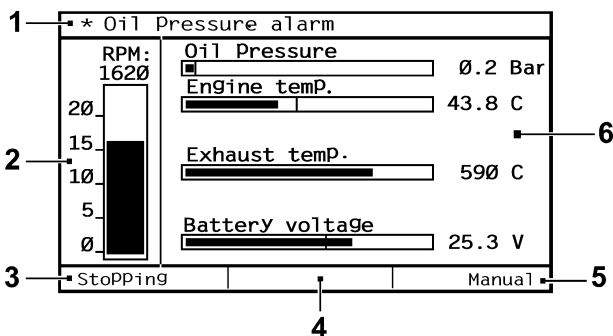
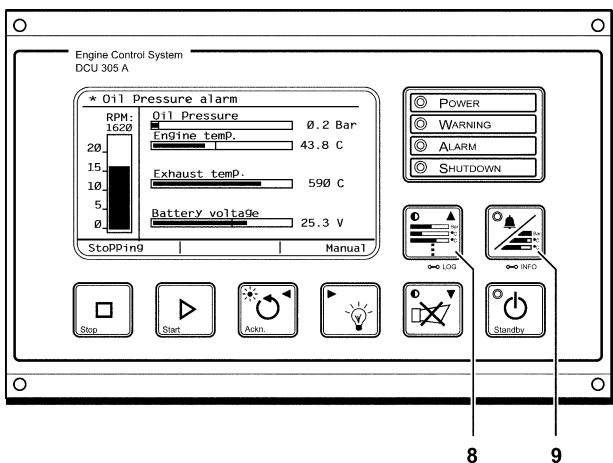
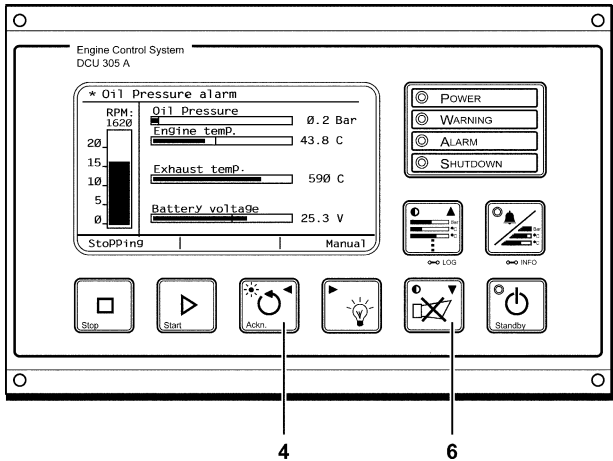

Views

There are four different screen views:

- Instrument view
- Sensor/alarm list
- Information view
- Event Log

Pushing the CHANGE VIEW button (9) will change from instrument view to alarm list. The information view is displayed by pushing the CHANGE VIEW button for one second. To get back to the previous view, the CHANGE VIEW button is pushed again. The log is shown when the log button (8) is pushed.

Instrument view

The instrument view is the main view of the control panel, it shows an upright standing tachometer (2), as well as a varying number of horizontal gauges (6) showing the positions of the analogue senders on the engine.

The status text fields located at the bottom of the instrument view (3, 4 and 5) shows current running mode.

At the top of the instrument view is a field, in which the first alarm to start will be described with a text string. The text in the field blinks with inverted text until the alarm is acknowledged. At the upper left corner of the screen * and + is alternately seen when an alarm is active.

The */+ blinking will end when the ACKNOWLEDGE button is pushed to acknowledge the alarm. The inverted text disappears when the alarm stops.

```

Water flow shutdown
Fuel leakage alarm
Oil temp. alarm
Oil Pressure alarm
Engine temp. alarm
Water level alarm
Oil Pressure shutdown
* Engine temp. shutdown
Engine temp.
Exhaust temp.

```

Alarm list

The alarm list shows all alarms that are predefined. Scroll the alarm list using the UP and DOWN buttons.

When an alarm is active it will be inverted in the alarm list and an indicating */+ blinking will appear in front of the text.

When the alarm is acknowledged, using the ACKNOWLEDGE button, the blinking will cease, but the alarm will remain active and the inversion of the text will remain. When the alarm stops, the text will go back to normal.

The alarm LED on the control panel is lit when an alarm is active. If more than one alarm is active at one time, the LED in the CHANGE VIEW button is lit.

NOTE! In this view the acknowledge-button will acknowledge all alarms simultaneously.

NOTE! Signals from optional relay cards are not displayed in the alarm list.

```

*****
* TAMD 163A *
* VOLVO PENTA *
* Serial number: 110155392/0025 *
*****
Mode: Auxiliary
Engine hours: 6802.06
Latest run: 14.20
Engine starts: 703
Start failures: 0
Time [UTC]: 2001.09.12 08:47:00

```

Information view

The information view show information concerning the engine and generator. The following engine variables are shown:

- Running mode
- Total engine running hours
- Engine running hours, latest run
- Number of engine starts
- Number of start failures

At the bottom of the screen, current time and date is displayed, using UTC standard.

NOTE! After 60 seconds in this view, the control unit automatically returns to the "Instrument view".

```

1297.40 Stop command
1283.80 Engine started
1283.80 Start command
1283.80 Acknowledge button
1283.80 Engine stopped
1283.80 Alarm: High engine temp. SHUTDOWN
1283.60 Alarm: High engine temp. ALARM
1281.10 Acknowledge button
1281.00 Alarm: Low oil Pressure ALARM
1276.00 Engine started
1275.90 Blackout start command
1275.90 Standby ON
1275.90 Engine stopped
1275.90 Stop command
1259.20 Engine started
1259.20 Start command
1259.20 Acknowledge button
1259.20 Alarm: Start battery low voltage

```

Log list

The log lists all events, specified with the engine running hours at their occurrence. The log stores up to 250 events in a permanent memory. Log data is saved even during voltage drop and power failure.

To scroll through the events listed in the log, the UP and DOWN buttons are used.

Starting the genset

The control unit does not have to be in Manual mode for the genset to be started manually.

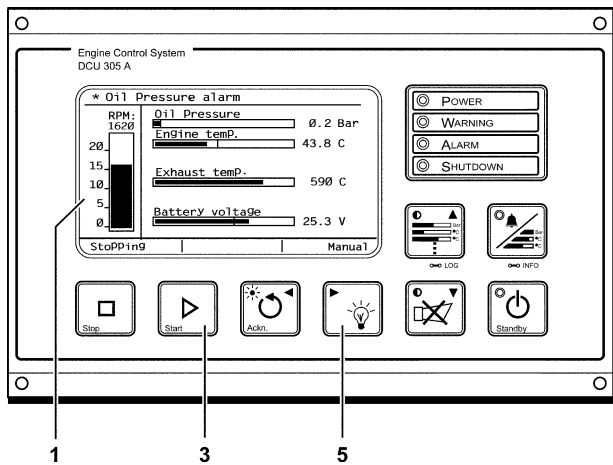

1. Press the LAMPTEST button (5) on the control panel to make sure that the LEDs on the panel are working. All working LEDs are lit up.
2. Push the START button (3) and hold it until a green LED in the button indicates that the genset is running.

When the genset is running the RPM is displayed on the screen (1) in the instrument view.

NOTE! To enable restart after autostop, alarms and messages from the control unit must be acknowledged.

⚠ IMPORTANT! If the starter motor has been engaged for the maximum 30 seconds, it must be allowed to cool down for at least one minute before a new starting attempt is made.

Check the readings on the LCD screen and run the genset at low load (if possible) until it reaches normal operating temperature.

Operation

Learn how to handle the genset, controls and other equipment in a safe and correct manner before taking it into operation.

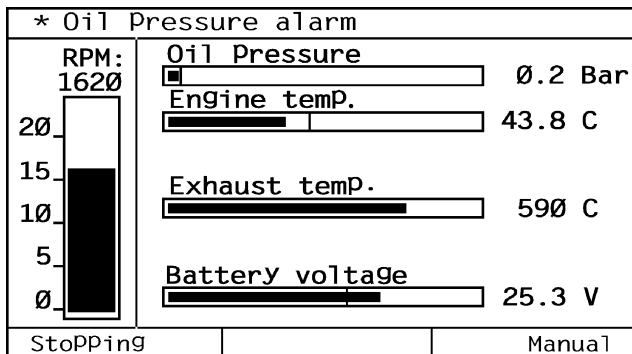

Checking the LCD screen

Check the LCD screen regularly during operation to make sure that all values are normal.

Oil pressure, engine

Refer to chapter Technical data.

Coolant temperature

Refer to chapter Technical data.

Exhaust temperature

Refer to chapter Technical data.

Charging

Refer to chapter Technical data.

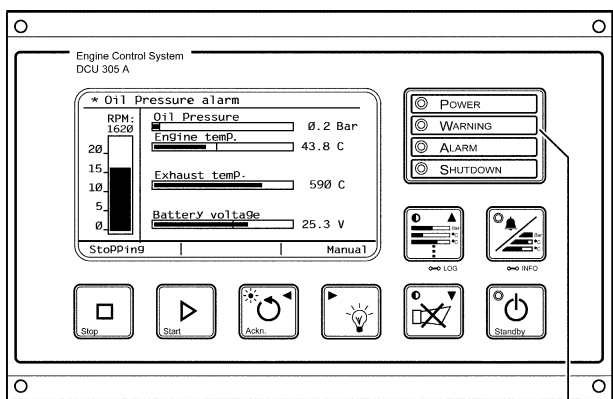

10

Indicating LEDs

The control unit has three main LEDs (10) for indication:

POWER indicates that the control unit is turned on. Flashes when low voltage.

WARNING indicates minor technical errors not related to genset running conditions (e.g. defective transmitters). Does not need immediate attention.

ALARM indicates one or more active alarm. Flashes when not acknowledge.

SHUTDOWN indicates that the genset has been stopped. The LED is lit until the engine has stopped completely.

Four of the buttons (STOP, START, STANDBY and CHANGE VIEW) also contain LEDs:

STOP button - lit when the genset is stopping.

START button - lit when the genset is starting.

STANDBY button - lit to indicate standby mode and not lit when the control unit is in manual mode.

CHANGE VIEW button - lit if more than one alarm is active at one time.

Stopping the genset

Let the engine run without load for at least three minutes before turning it off. This will keep the engine temperature in balance and prevent the engine from overheating.

⚠ IMPORTANT! The above procedure is specially important if the engine has been heavily loaded.

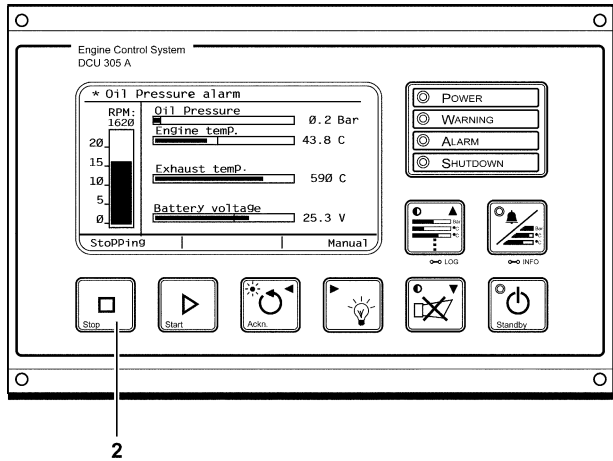

Use the red STOP button (2) to manually stop the genset. The control unit does not have to be in Manual mode to be manually stopped.

The button can be released at once. The stop function is active for a preset time. A red LED in the STOP button indicates that the stop function is active.

Operation

General

Learn how to handle the engine, controls and other equipment in a safe and correct manner before starting the engine

⚠ WARNING! Stay clear of all rotating and moving parts during operation.

⚠ IMPORTANT! Always keep the engine room well ventilated. Insufficient air supply to the engine means imperfect combustion and generator cooling and a loss of power.

⚠ IMPORTANT! Do not turn OFF the battery switch when the engine is running since this may damage the alternator.

⚠ WARNING! A hot engine may cause burns. Beware of hot surfaces. E.g.: exhaust manifold, turbocharger, oil pan, charge air pipe, starting heater, hot coolant and warm lubricant in pipes and hoses.

⚠ IMPORTANT! Avoid overloading. This can cause incomplete fuel combustion often indicated by black exhaust, high fuel consumption and carbon deposits in combustion chambers, affecting engine life.

⚠ IMPORTANT! Do not push the START button when the engine is running, this may damage the starter.

Applying load

If possible, do not apply heavy loads until the engine has reached operating temperature.

During load operation make sure that:

1. No engine related alarms occur.
2. There are no visible leaks of fuel, lube oil, coolant or exhaust gas.
3. No abnormal noise or vibrations occur.
4. The color of the exhaust gas is normal.
5. Instrument readings are the normal, refer to chapter Technical Data.

Stopping

Allow the engine to run at low idling speed (in neutral) for at least 5 to 6 minutes before turning it off. This will keep the engine temperature in balance and prevent it from boiling.

⚠ IMPORTANT! The procedure described above is especially important if the engine has been run hard and/or exerted to heavy loads.

⚠ IMPORTANT! Do not rev up the engine just before stopping it.

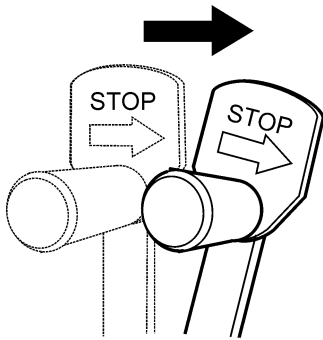

⚠ IMPORTANT! If the engine stops abnormally, try to locate the problem and make the repairs needed before starting again. After starting the engine, make sure the engine runs properly.

Manual stop lever

By pulling the manual stop lever in the “STOP” direction the engine can be stopped manually. Use this lever only in an emergency when the engine can not be stopped by the engine control system.

⚠ IMPORTANT! When stopping the engine by pulling the stop lever, continue to pull the lever until the engine stops “rocking.”

Notice: If the engine cannot be stopped with the manual stop lever, shut off the fuel supply or block air intake to turbo.

After stopping

General

- * Check the genset and engine room for leaks.
- * Close the fuel cock and rawwater cock.
- * Read off the hour counter and carry out preventive maintenance according to the maintenance schedule.
- * Turn off the main switch if the genset is not to be used for a long period.

⚠ IMPORTANT! Never turn the power off using the main switch while the genset is running. This can damage the alternator.

⚠ IMPORTANT! Make sure the generator heater is working properly to avoid condensation in the generator

Anti-freezing measures

If the engine room cannot be protected from frost, the rawwater system must be drained (if it contains rawwater) and the coolant in the freshwater system must contain the right mix of anti-freeze and water. Refer to chapter Maintenance "Rawwater system" and "Freshwater system" respectively.

 **WARNING!** If the rawwater system bursts due to freezing, the vessel could sink.

 **IMPORTANT!** If the coolant does not give sufficient anti-freeze protection, it may cause costly damage to the engine.

NOTE! Check the charge of the battery. A poorly charged battery can freeze and break.

Breaks in operation

During periods out of service, the engine must be run warm once a fortnight. This will prevent it from corroding.

 **IMPORTANT!** The genset must be conserved if it is not to be used for longer than two months. Refer to chapter Inhibiting.

Maintenance

Your Volvo Penta engine and associated equipment is designed to provide high operational reliability and long service life. They are constructed to withstand the marine environment while also affecting it as little as possible.

Preventive maintenance in accordance with the maintenance schedule will ensure that it retains these qualities and avoid unnecessary operational disturbances. The following chapters contain general technical information and directions for carrying out the prescribed maintenance points. Read the directions carefully before starting work.

The maintenance schedule shows the standard service intervals. When you think the engine should be serviced more frequently due to particular operating conditions, adjust the intervals accordingly. Appropriate service intervals vary with usage and operating conditions and with fuel, lubricant and coolant used. Due to particular operating conditions the service intervals may be adjusted accordingly. Consult your Volvo Penta dealer.

NOTE! Dust and foreign particles are the most common cause of excessive wear of parts. When disassembling a component, take measures to prevent dust and foreign particles from entering it.

Daily operation records

It is recommended to keep daily operation records. Daily recording is a preventive maintenance program and when comparing values with engine history it will help you recognize conditions, signs or indications of approaching trouble. Daily operation records also make trouble shooting easier and will lessen the down time (to save time and money for servicing).

Maintenance records

Volvo Penta recommends that accurate maintenance records are kept. With accurate maintenance records your Volvo Penta Dealer can help in fine tuning the recommended service intervals to meet the specific operating situation. This should result in a lower engine operation cost.

Fluids

It is also important to keep record of the fluids used in the engine. If brand or type of fuel, lubrication oil or coolant is changed this should be recorded.

Warranty inspection

The prescribed warranty inspection "First Service Inspection" must be carried out at an authorized Volvo Penta workshop during this first period of operation. Directions for when and where this is to be carried out can be found in the **Warranty and Service Book**.

 **WARNING!** Read the safety directions for maintenance and service in the chapter "Safety information" before starting work.

 **WARNING!** Read the chapter "Maintenance" thoroughly before starting any maintenance work. It contains directions for performing maintenance in a safe and correct manner.

 **WARNING!** Working on or approaching a running engine is a safety hazard. Maintenance and service must be carried out with the engine stationary unless stated otherwise in the instructions. Prevent inadvertent start of the engine by disabling the start-button and turning off the power with the main switch, locking it in the off position.

 **WARNING!** Place warning signs stating that service is in progress in every position from which the engine can be started.

 **IMPORTANT!** Handle parts carefully. Use only original Volvo Penta spare parts.

NOTE! When both operating time and calendar time is given, the one occurring first is to apply.

NOTE! For generator related maintenance information, refer to Generator Manufacturers information.

MAINTENANCE SCHEDULE D34A MS GENSET

Daily before first start

- General inspection engine and engine room
- Check and make sure all valves are in the right position
- Check lubrication oil level
- Check coolant level
- Drain water from fuel tank
- Drain water from fuel pre-filter/water separator
- Drain water from air vessel and air filter (for air starters applications)
- Check engine control system (cables, etc.)
- Check fuel control linkage
- Check aftercooler drain pipe
- Daily operation records
- Inspection of valves and plugs

After start

- Check lubrication oil filter differential pressure indicator
- Check air-filter differential pressure indicator
- Check if the instrumentation works properly
- Check for leakages

Weekly

- Check starting batteries; electrolyte level/load
- Check electrical system for loose terminals/contacts
- Check foundation bolts
- Check lubrication oil for abnormal smell or water dilution
- Check safety valves of air system
- Check air system oiler
- Check settings of valves and move valve to keep them operationable
- Drain water from the fuel pre-filter/water separator
- Drain crankcase ventilation water trap
- Drain exhaust silencer (system) water trap

First 50-250 operating hours of new or recond. engines (First service)

- Change lubrication oil
- Change full flow and by-pass lubrication oil filters
- Change governor lubrication oil filter
- Check/adjust V-belts
- Check/adjust valve clearance
- Check/adjust stop solenoid and/or fuel stop valve
- Check/retighten bolts and nuts

Every 250 operating hours or every 12 months

Change lubrication oil. Longer interval requires oil analysis
Change full flow and by-pass lubrication oil filters
Check/adjust V-belts
Check rawwater filter
Check/wash air inlet silencer filter

Every 500 operating hours or every 12 months

Change governor lubrication oil filter
Clean centrifugal by-pass lubrication oil filter⁽¹⁾

Every 1000 operating hours or every 12 months

Change fuel filter elements
Change filter elements of the fuel pre-filter/water separator
Check air filter (if installed)
Check/retighten bolts and nuts
Check/adjust fuel injection timing
Check/adjust fuel injection pressure and spray pattern
Change fuel injection nozzle o-rings
Check and adjust valve clearance and valve mechanism

Every 2000 operating hours or every 12 months

Check/adjust valve clearance. Check valvemechanism
Check turbocharger
Check starter motor
Check alternator
Check fuel injection pump flex drive plates
Check fuel injection pump control rack operation
Check fuel rack control "ball joints"
Check/clean charge air cooler(s)
Check/clean cooling water heat exchanger
Check coolant concentration
Check torsional vibration dampers
Check alarm and shut-down functions
Check engine control panel functions
Change V-belts
Change fuel pre-filter/water separator element
Check/change zinc anodes
Change air inlet silencer filter

Every 4000 to 6000 operating hours or every 24 months

Full service inspection⁽²⁾ consult Volvo Penta dealer

Every 12 months

Check rubber engine mounts
 Check rubber hoses and flex connections
 Check engine room ventilation fans

Every 10000 operating hours

Check torsional vibration damper temp check
 Check rubber of flexible coupling for deformation and cracks
 Replace ball-joints in fuel pump control linkage
 Check all instruments, senders and switches

Every 15000 operating hours

Full service inspection⁽³⁾ consult Volvo Penta dealer

Every 24 months

Change coolant

(1) In case by-pass filter is very dirty, shorten check interval to 250 hrs.

(2) Have an authorized dealer execute a full service inspection of your engine including:

- Endoscopic investigation of cyl heads and liners
- Replace all injector nozzles
- Change water pump seals
- Checking and cleaning of charge air cooler
- Check turbo charger
- Check battery-charging alternator
- Check and test stop solenoid and fuel shut-off valve

(3) Have an authorized dealer execute a full service inspection of your engine including:

- As described at 4000 – 6000 hrs
- Remove and inspect one piston, piston rings and liner
- Inspect crankshaft and one bearing
- Inspect camshaft and one bearing

MAINTENANCE SCHEDULE D34A MT GENSET

Daily before first start

- General inspection engine and engine room
- Check and make sure all valves are in the right position
- Check lubrication oil level
- Check coolant level
- Drain water from fuel tank
- Drain water from fuel pre-filter/water separator
- Drain water from air vessel and air filter (for air starters applications)
- Check engine control system (cables, etc.)
- Check fuel control linkage
- Check aftercooler drain pipe
- Daily operation records
- Inspection of valves and plugs

After start

- Check lubrication oil filter differential pressure indicator
- Check air-filter differential pressure indicator
- Check if the instrumentation works properly
- Check for leakages

Weekly

- Check starting batteries; electrolyte level/load
- Check electrical system for loose terminals/contacts
- Check foundation bolts
- Check lubrication oil for abnormal smell or water dilution
- Check safety valves of air system
- Check air system oiler
- Check settings of valves and move valve to keep them operationable
- Drain water from the fuel pre-filter/water separator
- Drain crankcase ventilation water trap
- Drain exhaust silencer (system) water trap

First 50-250 operating hours of new or recon. engines (First service)

- Change lubrication oil
- Change full flow and by-pass lubrication oil filters
- Change governor lubrication oil filter
- Check/adjust V-belts
- Check/adjust valve clearance
- Check/adjust stop solenoid and/or fuel stop valve
- Check/retighten bolts and nuts

Every 250 operating hours or every 12 months

Change lubrication oil. Longer interval requires oil analysis
Change full flow and by-pass lubrication oil filters
Check/adjust V-belts
Check rawwater filter
Check/wash air inlet silencer filter

Every 500 operating hours or every 12 months

Change governor lubrication oil filter
Clean centrifugal by-pass lubrication oil filter⁽¹⁾

Every 1000 operating hours or every 12 months

Change fuel filter elements
Change filter elements of the fuel pre-filter/water separator
Check air filter (if installed)
Check/retighten bolts and nuts
Check/adjust fuel injection timing
Check/adjust fuel injection pressure and spray pattern
Change fuel injection nozzle o-rings
Check and adjust valve clearance and valve mechanism
Check rawwater pump

Every 2000 operating hours or every 12 months

Check/adjust valve clearance. Check valvemechanism
Check turbocharger
Check starter motor
Check alternator
Check fuel injection pump flex drive plates
Check fuel injection pump control rack operation
Check fuel rack control "ball joints"
Check/clean charge air cooler(s)
Check/clean cooling water heat exchanger
Check coolant concentration
Check torsional vibration dampers
Check alarm and shut-down functions
Check engine control panel functions
Change V-belts
Change fuel pre-filter/water separator element
Check/change zinc anodes
Change air inlet silencer filter

Every 4000 to 6000 operating hours or every 24 months

Full service inspection⁽²⁾ consult Volvo Penta dealer

Every 12 months

- Check rubber engine mounts
- Check rubber hoses and flex connections
- Check engine room ventilation fans

Every 10000 operating hours

- Check torsional vibration damper temp check
- Check rubber of flexible coupling for deformation and cracks
- Replace ball-joints in fuel pump control linkage
- Check all instruments, senders and switches

Every 15000 operating hours

Full service inspection⁽³⁾ consult Volvo Penta dealer

Every 24 months

- Change coolant

(1) In case by-pass filter is very dirty, shorten check interval to 250 hrs.

(2) Have an authorized dealer execute a full service inspection of your engine including:

- Endoscopic investigation of cyl heads and liners
- Replace all injector nozzles
- Change water pump seals
- Checking and cleaning of charge air cooler
- Check turbo charger
- Check battery-charging alternator
- Check and test stop solenoid and fuel shut-off valve

(3) Have an authorized dealer execute a full service inspection of your engine including:

- As described at 4000 – 6000 hrs
- Remove and inspect one piston, piston rings and liner
- Inspect crankshaft and one bearing
- Inspect camshaft and one bearing

Recommendation of Daily Operation Records

Daily recording is a preventive maintenance program and when comparing values with engine history it will help you recognize conditions, signs or indications of approaching trouble. Daily operation records also make trouble shooting easier and will lessen the down time (to save time and money for servicing).

Items to be recorded

The following items are recommended to be recorded once a day:

1. Operating hours.
2. The amount of lubrication oil and coolant (fresh water) required for refilling. Fuel consumption.
3. Lubrication oil and coolant (fresh water) changes.
4. Lubrication oil pressure and temperature, engine rpm, exhaust temperature, coolant temperature, and charge air temperature and pressure.
5. Rawwater pressure and rawwater temperature before and after heat exchanger. Ambient temperature and engine room temperature at turbo charger inlet.
6. Parts serviced and kinds of service (adjustment, repairs or replacement).
7. Change in operating conditions (for example, "Exhaust smoke turned black," etc.)

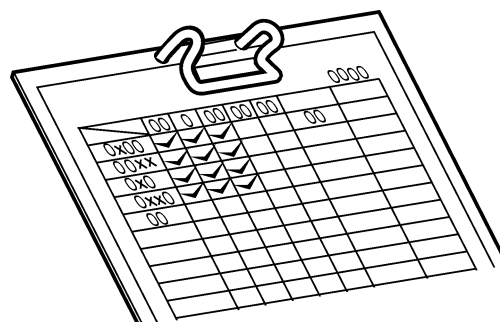

Engine

Valve clearance

Check and adjust the valve clearance on a cold engine. The valves are adjusted when the piston is at top dead center of compression stroke. The valve bridge is adjusted first, and then the clearance of the rocker arm.

⚠ IMPORTANT! The engine must under no circumstances be running when checking and adjusting the valve clearance since the valves can knock against the pistons and cause serious damage.

⚠ IMPORTANT! Make sure that the stop lever is pulled out and the starter key switched off.

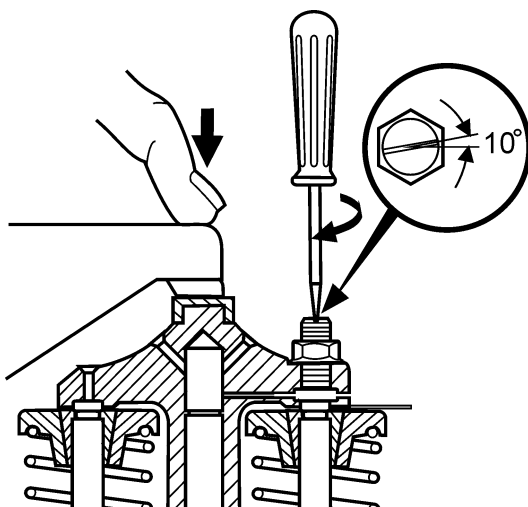
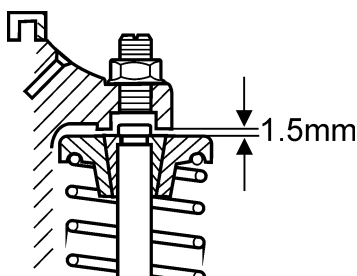
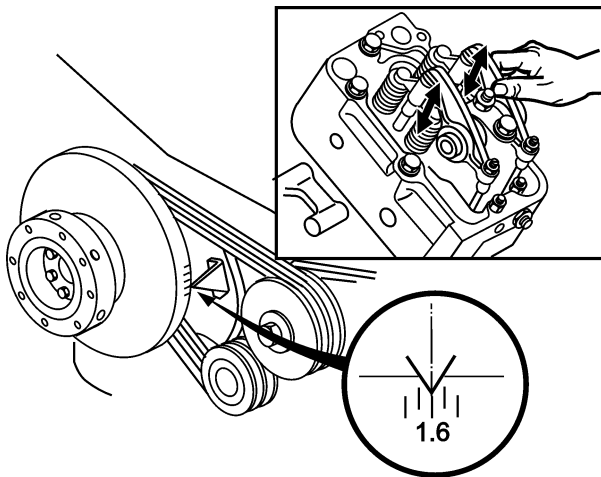

Top dead center on compression stroke

1. Turn the engine in the normal direction to align the timing mark [1.6] on the damper with the pointer as shown.
2. Remove the rocker cover of the cylinder on which the valve clearance is to be checked and adjusted, and make sure the inlet and exhaust valves have some clearance. If the timing mark [1.6] is aligned with the pointer, either the No. 1 or No. 6 piston is at top dead center on the compression stroke.

Adjust the valve bridge

⚠ IMPORTANT! Make sure the clearance between the valve bridge and valve rotator is 1.5 mm [0.059 in.] or more if not, interference will occur between the bridge and rotator to cause the valve cones to get out of place. If the clearance is less than 1.5 mm [0.059 in.] after the height of valves has been adjusted, consult your dealer.

NOTE! Before inspecting the valve clearance, adjust the height of the two valves. Bring the bridge into contact with the valves, by means of the valve-bridge adjusting screw, so that there is no difference in height between the two valves. If the valve seats are worn, one valve will differ from another in height, increasing the clearance between the valve stem and bridge, leading to an increased valve clearance.

1. Unscrew the lock nut and adjusting screw on the pair of valves on the cylinder so that there is clearance between the yoke and the valve stem.
2. Press the valve yoke down. Turn the adjusting screw so that it makes contact with the valve stem.
3. Turn an additional 10 degrees. Lock the adjusting screw with the lock nut.

NOTE! Check if the bridge is properly adjusted, by putting a little drop of oil the valve stem top.

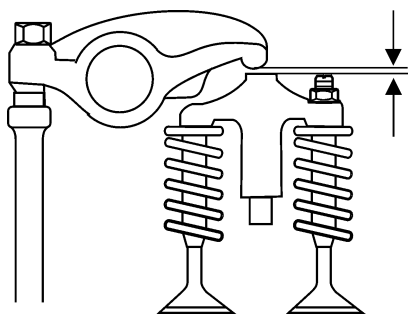

Valve clearance inspection

1. Check the valve clearance with feeler gauges inserted between the rocker arm and yoke cap.

Valve Clearance:

Inlet valve 0.4 mm [0.016 in.]

Exhaust valve 0.5 mm [0.020 in.]

2. The clearance is correct if feeler gauge is slightly gripped between the rocker arm and the yoke cap. If the feeler does not fit into the clearance exactly, perform adjustments as described below.

⚠ IMPORTANT! When performing the "First Service", valves that are checked and deemed not in need of adjustment must be checked again within 250 hours.

NOTE! Standing next to the engine, facing the cylinder head, the inlet valve is to the left and the exhaust valve is to the right

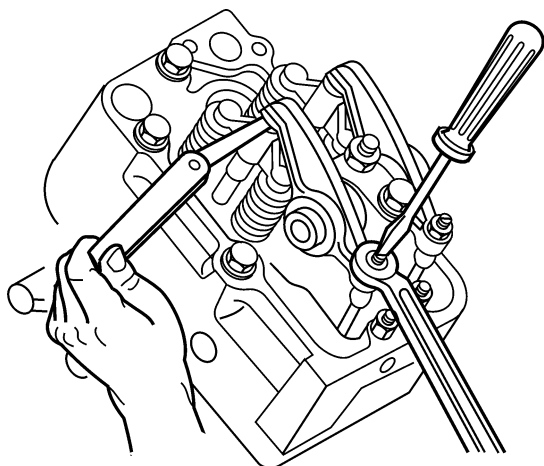

Adjust valve clearance

1. Loosen the lock nut of the adjusting screw.
2. Turn in or back off the adjusting screw so that feeler gauge is slightly gripped between the rocker arm and yoke cap.
3. After adjusting the clearance, tighten the lock nut of the adjusting screw.

Firing order

Check and adjust the valve clearance in the firing order (injection sequence), turning the engine with each cylinder piston at top dead center on compression stroke.

Firing order 1 12 5 8 3 10 6 7 2 11 4 9

(Example): After checking and adjusting the cylinder No.1, turn the engine 60° and check and adjust the cylinder No. 12.

Cylinder No.	1	12	5	8	3	10	6	7	2	11	4	9
Timing (°)	0	60	120	180	240	300	360	420	480	540	600	660

Turning the engine

Insert the turning bar in the holes on the flywheel.
Turn the engine manually.

⚠ Warning! Make sure the turning bar is removed before cranking the engine.

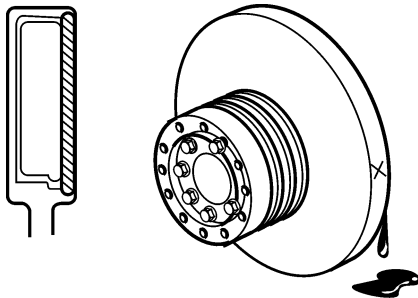

Vibration damper inspection

NOTE! When installing a damper protective cover on the engine, do not use a cover enclosing the damper.

Visually check for fluid leaks, flaws, distortion, or discoloration or flaking of painted surfaces. Also check for swelling (by measuring with a scale), and fluid leaks past staked portions.

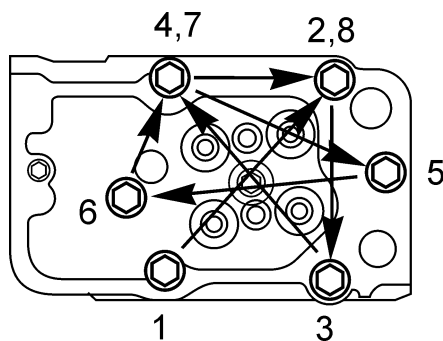

Re-tighten bolts and nuts

Re-tighten the bolts and nuts on the following components:

- * Timing gear case
- * Crankshaft pulley
- * Mounting brackets
- * Exhaust manifold
- * Turbocharger
- * Cylinder heads

Check the cylinder head bolts and re-tighten them in number sequence (1-2-3-4-5-6-7-8) if necessary. The tightening torques of the bolts and nuts can be found in technical data section of this manual.

NOTE! In case retightening is necessary, first unscrew the bolts completely.

Lubrication system

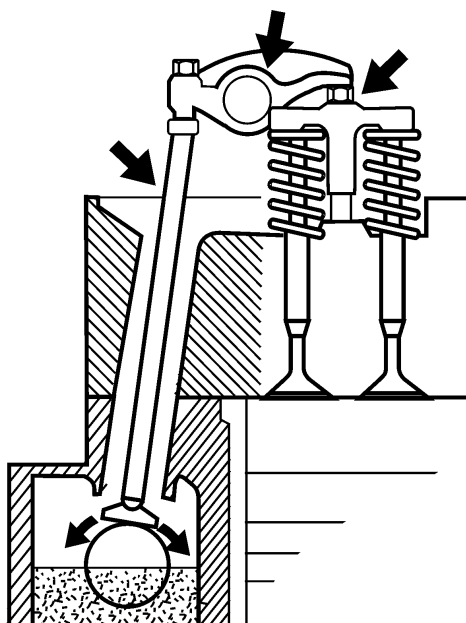
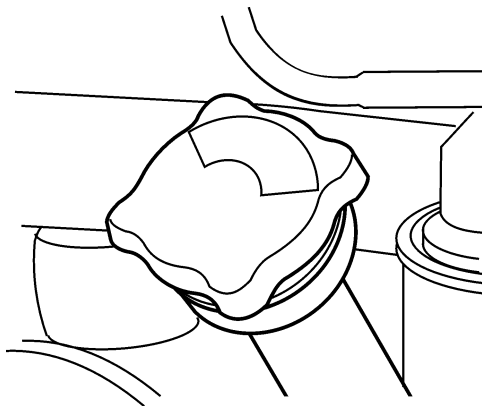
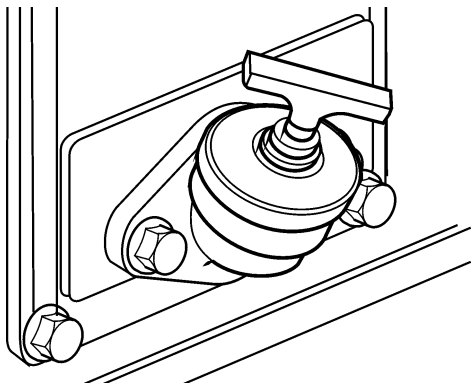

Checking oil level

The oil level must be within the marked range on the dipstick and must be checked daily.

⚠ IMPORTANT! The level must never be allowed to drop beneath the minimum or rise above the maximum mark on the dipstick.

Filling oil

Fill the engine with lubrication oil through the filler pipe. For oil specification refer to chapter technical data. The oil level should be within the marked area on the dipstick. After filling oil, secure filler cap.

⚠ WARNING! Lubrication oil on hot surfaces or electrical components may cause fire. Do not smoke while filling oil or when handling oil containers.

⚠ IMPORTANT! Stop the engine when filling oil.

⚠ IMPORTANT! Avoid mixing oils of different brands, additives used in the oils can cause chemical reactions that may degrade the oil performance.

⚠ IMPORTANT! The lubrication oil level must never be allowed to drop beneath the lower, or rise above the maximum, mark on the dipstick.

Filling oil in new or reconditioned engine

If your engine is new or reconditioned you should besides the actual filling of new lubrication oil also do the following:

1. Remove the rocker cover. Lubricate the valve mechanism and fill the camshaft oil bath from the cylinder head. Repeat the procedure for each cylinder.
2. Mount all the rocker covers. Refer to section Tightening torques for proper torques.

NOTE! Avoid running or cranking the engine without the rocker covers mounted.

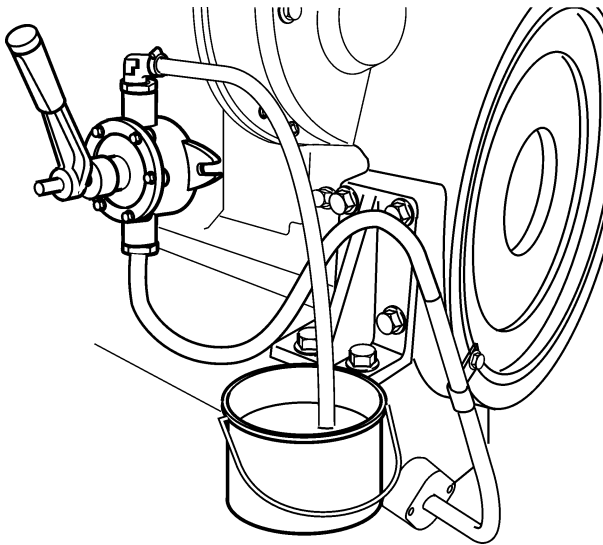

Changing oil

Always observe the recommended oil change interval.

⚠ IMPORTANT! Only use recommended grades of oil (see chapter technical data).

1. Warm up the engine (this makes it easier to suck the oil up from the sump). Then stop the engine.

⚠ WARNING! Hot oil and hot surfaces may cause burns.

2. Connect a hose to the outlet pipe of the lubrication oil scavenging pump. Pump the oil out.

NOTE! Collect the old oil and filters and deposit in accordance with local regulations. Never dispose of old oil or oil filters overboard.

3. Change the oil filters and the by-pass filter (if applicable) at every oil change (please refer to section oil filters change).
4. Fill with oil to the correct level through the oil filling pipe.
5. Start the engine and allow it to idle. Check the oil pressure and make sure that there are no leaks by the filters.

⚠ WARNING! Approaching or working with a running engine is a safety risk. Be careful to avoid rotating components and hot surfaces.

6. Stop the engine. Wait a few minutes before you check the oil level. Top up if necessary.

Changing oil filter

Each pair of filters has its own shut off valve located on the housing between the filters. The oil filters can be changed while the engine is running as the oil flow can be directed through two filters at a time.

⚠ WARNING! Always keep all four filters in operation under normal operating conditions.

⚠ WARNING! Reduce the engine speed to idle when changing oil filters on a running engine.

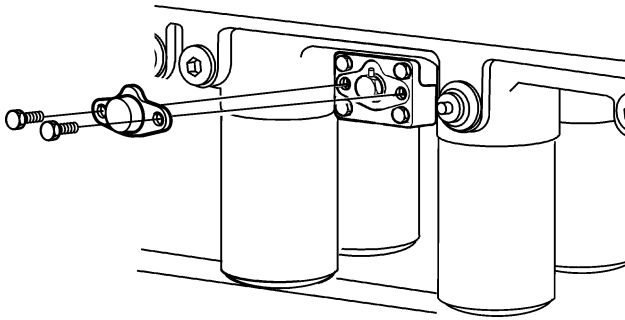

1. Remove the cover from the filter switch valve by disconnecting the two bolts.

⚠ WARNING! Working on or approaching a running engine is a safety hazard. Beware of rotating parts and hot surfaces.

2. Cut off the oil flow through the right filters by turning the setting valve in position C.
3. Unscrew the oil filter using the special tool. Discard the filter.

NOTE! Place a drip pan beneath the filter when removing to avoid oil spill.

4. Lightly oil the new filter's rubber gasket and check its mating surface on the mounting.

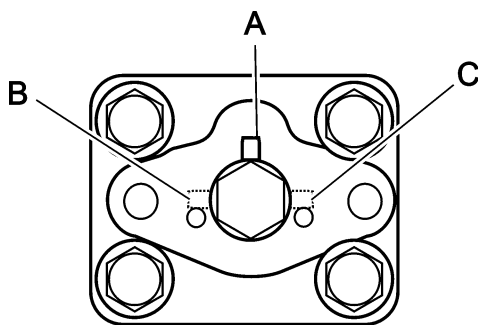

A: Normal running (all filters connected).

B: Left filters can be changed.

C: Right filters can be changed.

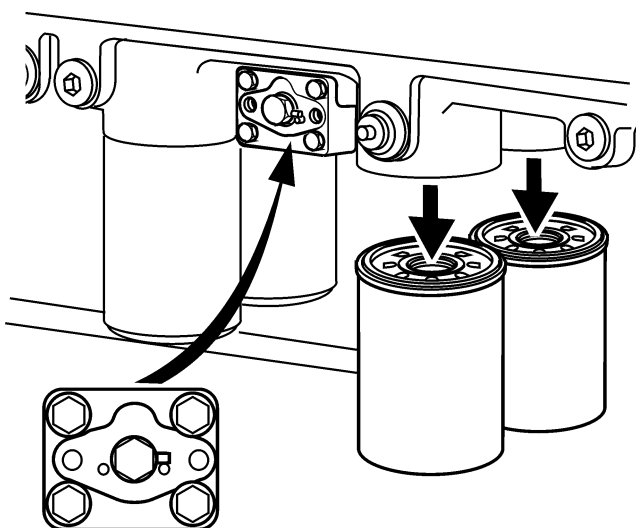

5. Mount the new filter by hand until the gasket is in contact with the sealing surface. Then tighten the filter a further approximately 3/4 of a turn.

6. Put the filter on-line by turning the valve in position A.

7. Replace the left filters as above. Position B is the left filters change position.

8. Replace all four full-flow filters at the same time.

NOTE! After a lubrication oil filter change, open the filter and check for metal parts.

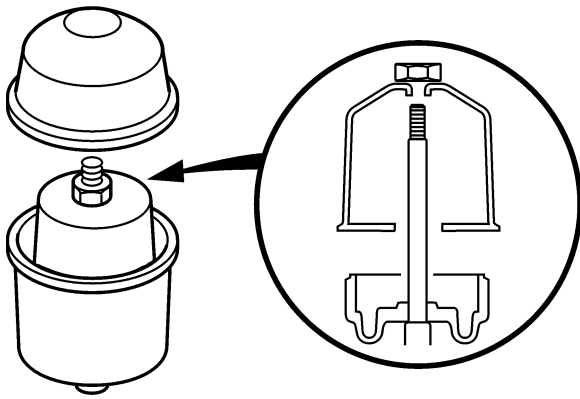

Cleaning centrifugal by-pass oil filter

Remove the cover and clean inside with clean diesel.

NOTE! In case by-pass filter is very dirty, shorten check interval, refer to chapter "Maintenance schedule".

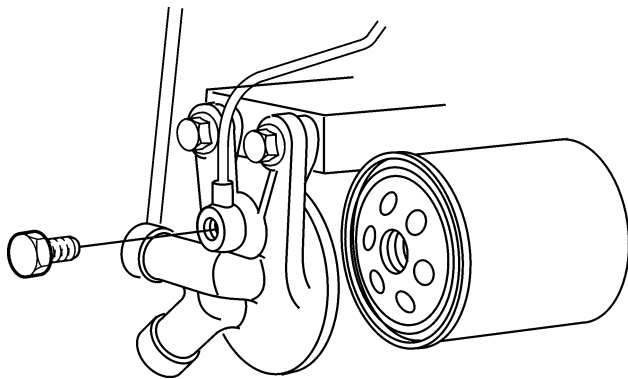

Changing hydraulic governor oil filter

1. Stop the engine.
2. Place a drip pan under the governor oil filter.
3. Remove the governor oil filter with a filter wrench.
4. Clean the gasket for the new filter and coat it with clean engine oil.
5. Fit the new filter and tighten it by hand.
6. Remove the air vent plug and fill filter with engine oil. Reinstall the plug.
7. Operate the priming pump or the wing pump to circulate engine oil. Check for leaks, tighten filter if necessary.

Checking the oil

After an oil change always check the oil. Smell it for strange smells and visually check it for the presence of fuel or water.

Fuel system

- ⚠ WARNING!** Always protect your hands when carrying out leak detection. Escaping fluids under pressure can pierce bodily tissue and cause serious injury. Risk of blood poisoning. Always cover any electric component if it is located under the fuel filter. Otherwise it might be damaged by fuel spills.
- ⚠ WARNING!** Work performed on the fuel system must be done on a cold engine. Fuel leaks and spills on hot surfaces or electrical components can cause fires.

Bleeding the fuel system

- ⚠ IMPORTANT!** Place a drip pan under the fuel filters.

Prime the fuel filters and fuel injection pump in the following sequence:

Bleeding the fuel filter

1. Put the fuel filter switching cock in the left filter bleed position and loosen the left air vent plug.

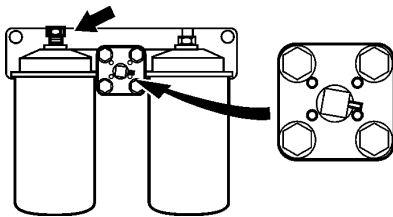

2. Turn the priming pump plunger counterclockwise to unlock the mechanism.

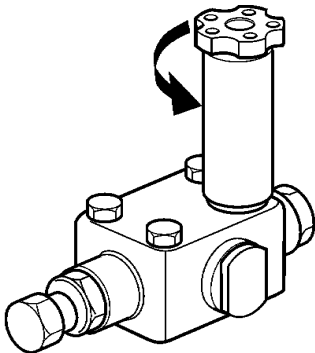

3. Move the plunger up and down until the fuel flows free of bubbles from air and tighten the air vent plug.

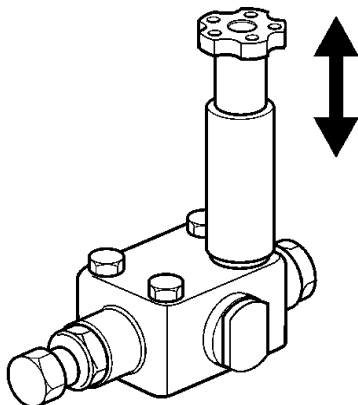

4. Put the fuel filter switching cock in the neutral position and repeat the above-described procedure for the other fuel filter.

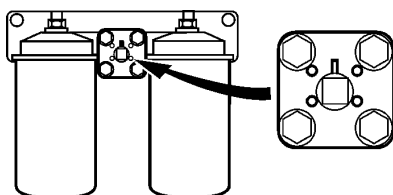

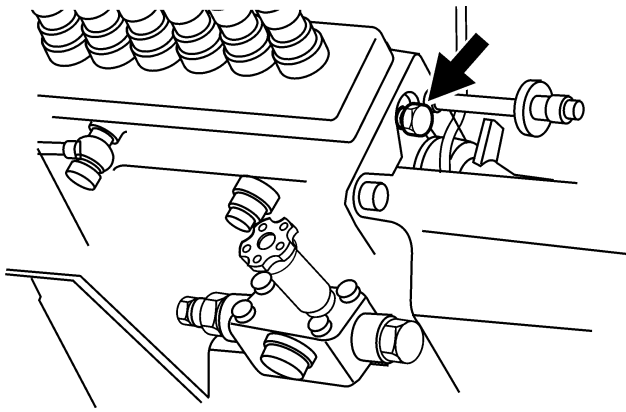

Bleeding the fuel injection pumps

1. Loosen the air vent cock on the fuel injection pump about 1.5 turns.

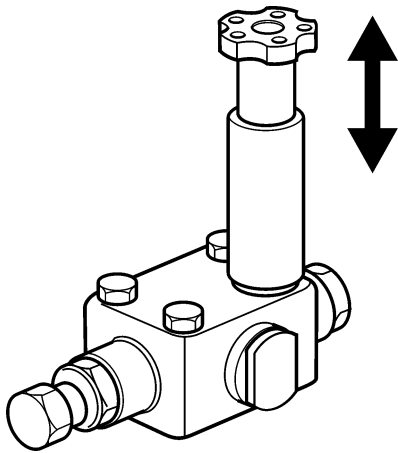

2. Move the priming pump cap up and down to start the flow of fuel through the system.
3. When the fuel coming out of the air vent cock shows no visible bubbles, lock the priming pump cap while holding it down. Then tighten the air vent cock.

Be sure to lock the priming pump cap before tightening the air vent plugs and cock. If this is not done the cap does not return to the original position due to the pressure in the priming pump.

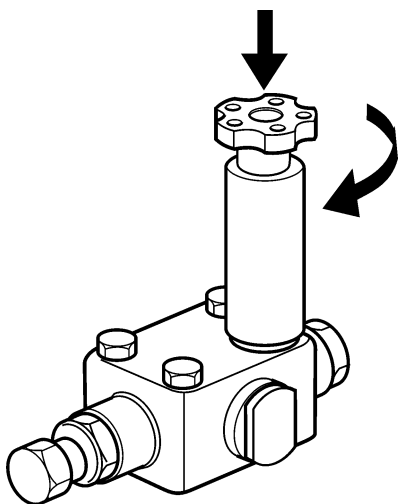

4. Tighten the priming pump cap by hand until the tightening force increases, normally this occurs after turning it approximately 70 to 90 degrees. Mark this position on the priming pump cap to make item 5 work more easily.
5. Tighten the priming pump cap an additional 120 to 150 degrees using a wrench.

NOTE! Be sure to bleed both injection pumps.

6. Clean the engine from spoiled fuel to prevent fire and pollution of the environment.

⚠ IMPORTANT! If the priming pump cap is tightened too much (more than 240 degrees in total), the top of the priming pump can be damaged.

⚠ IMPORTANT! Looseness of the priming pump cap in combination with engine vibration may cause engine failure and damage to the installation.

Changing the fuel filter

Switchable fuel filters can be changed while the engine is running as the flow of fuel can be cut off to one filter at a time.

⚠ WARNING! Working on or approaching a running engine is a safety hazard. Beware of rotating parts and hot surfaces.

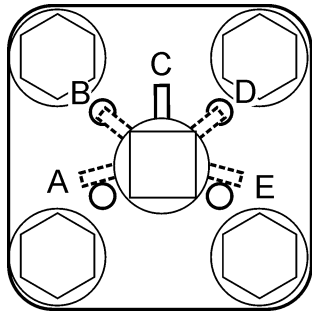

- A. Right Filter bleed position
- B. Right Filter change position
- C. Neutral position
- D. Left Filter change position
- E. Left Filter bleed position

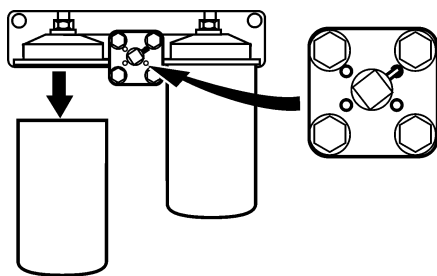

1. Place a drip pan under the fuel filter.
2. Put the fuel filter switching cock in the Left filter change position and unscrew the left-hand fuel filter. Use a filter wrench if necessary.
3. Coat the gasket of a new filter with clean diesel fuel.
4. Install the new filter in the filter bracket by hand. When the gasket contacts the base, tighten 1/2 to 3/4 of a turn more.

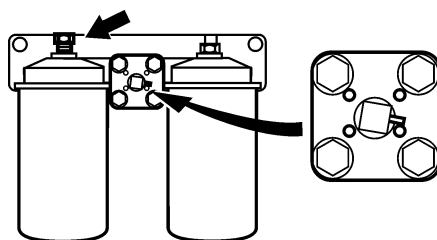

5. Put the fuel filter switching cock in the Left filter bleed position and loosen the left air vent plug until the fuel running out is free from air. Close the air vent.

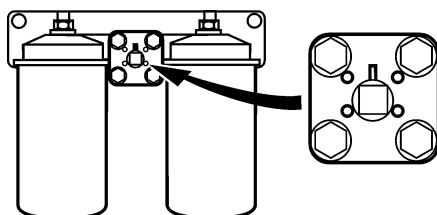

6. Put the fuel filter switching cock in the neutral position and repeat the above described procedure for the other fuel filter.

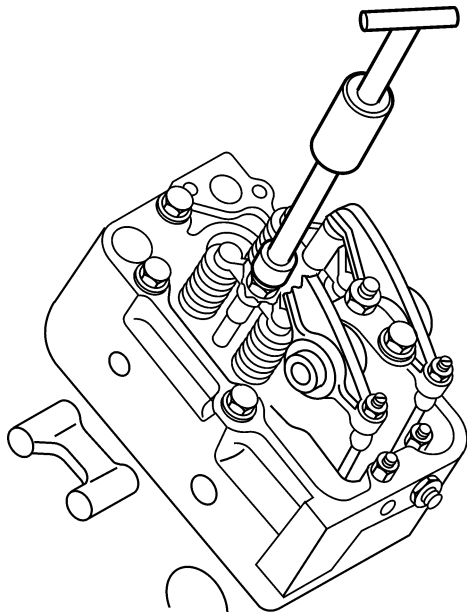

Changing the fuel injector nozzle

⚠ IMPORTANT! Cover all open fuel injection pipes, fuel intake openings and the fuel injection nozzle to keep dirt out

Removing the fuel injector

1. Remove the rocker cover.
2. Remove the clamp from the fuel injection pipe.
3. Remove the fuel injection pipe from the fuel injector.
4. Remove the injector inlet connector.
5. Remove the injector gland nut to take off the gland.
6. Pull out the fuel injector using the special tool.

Removing the nozzle

⚠ IMPORTANT! The injector nozzle is very delicate, handle with care.

1. Fasten the fuel injector in a vice with protection plates.
2. Remove the set screw and the cap nut.
3. Loosen the adjusting screw with a screw driver until it can be loosened by hand.

Note! This operation is required to release spring pressure applied to the nozzle. When spring pressure is applied, it is hard to loosen the retaining nut.

3. Remove the retaining nut and remove the nozzle.

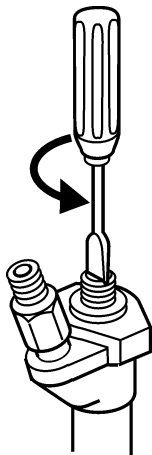

Cleaning the nozzle

⚠ IMPORTANT! Do not mix up the pairing of needle valve and body when cleaning more than one at a time.

1. Dip the nozzle in clean fuel oil and disassemble the needle valve.
2. Clean the injection holes.
3. After cleaning, carefully insert the needle valve into the body in clean oil.

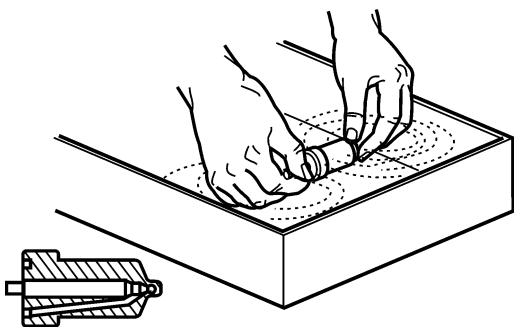

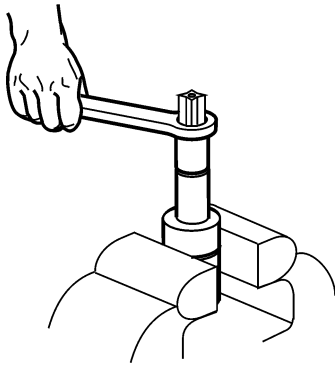

Installing the nozzle

1. Install the nozzle according to the pin on the nozzle.
2. Tighten the retaining nut by applying the specified torque 177 to 196 Nm (18 to 20kpm) [130 to 145 lb.ft.]. (Apply oil to the nut.)

⚠ IMPORTANT! Do not use Moly Disulfide.

3. Adjust the nozzle opening pressure and check spray conditions.

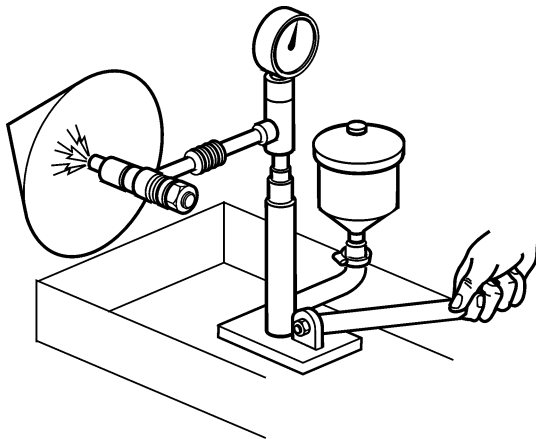

Fuel injection pressure

⚠ WARNING! Do not allow the fuel injected from a nozzle to contact the skin or body when inspecting the nozzle using a nozzle tester. The fuel injected from the nozzle has an extremely high pressure, strong enough to penetrate skin and causing serious injury.

1. Attach the fuel injector to the nozzle tester.
2. While watching the pressure gage of the nozzle tester, push the handle down slowly.

⚠ IMPORTANT! If fuel drips from the end of the nozzle tip it must be replaced.

3. When the handle is being pressed down, the fuel is injected, and the pressure on the pressure gage drops suddenly. The pressure value indicated at this point is the fuel injection start pressure.
4. Close the valve on the injection pump. If the pressure on the gage drops too fast (most probably due to leakage) the nozzle must be replaced.

NOTE! Make sure it isn't the injection pump itself that is leaking.

Nozzle opening pressure

21.57 MPa (220 kp/cm²) [3130 psi]

Fuel injection nozzle spray pattern

Check spray conditions when checking fuel injection pressure. Good spray conditions are as follows:

- Fuel is injected from all nozzle holes.
- The fuel is sprayed in a conical shape.
- No big particles but fine ones.
- No oil drip is left after injection.

If the nozzle fails to spray fuel properly, replace with a new one.

NOTE! Fuel injection pressure and nozzle spray pattern check intervals may be extended in steps of 250 hours if they are ok at 1000 hrs.

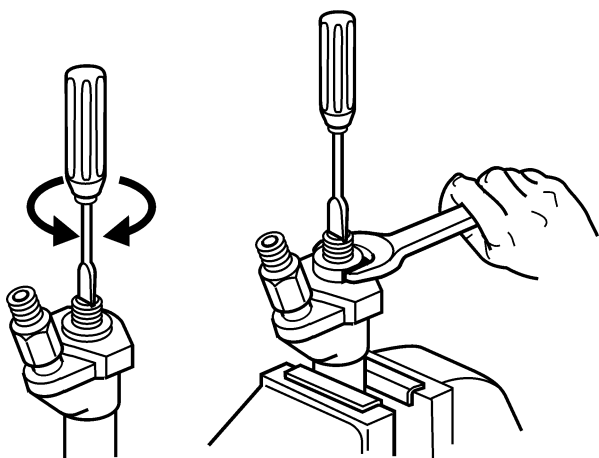

Adjusting the fuel injection pressure

1. To adjust injection pressure, remove the cap nut from the nozzle holder, and then turn the adjusting screw. To increase the injection pressure, tighten the screw. To decrease the injection pressure, loosen the screw.
2. When the pressure meets the standard value, tighten the cap nut to 39 - 49 Nm (4 - 5 kpm) [29 - 36 lbf.ft].
3. Tighten the set screw to 15 - 20 Nm (1.5 - 2 kpm) [11 - 15 lbf.ft].

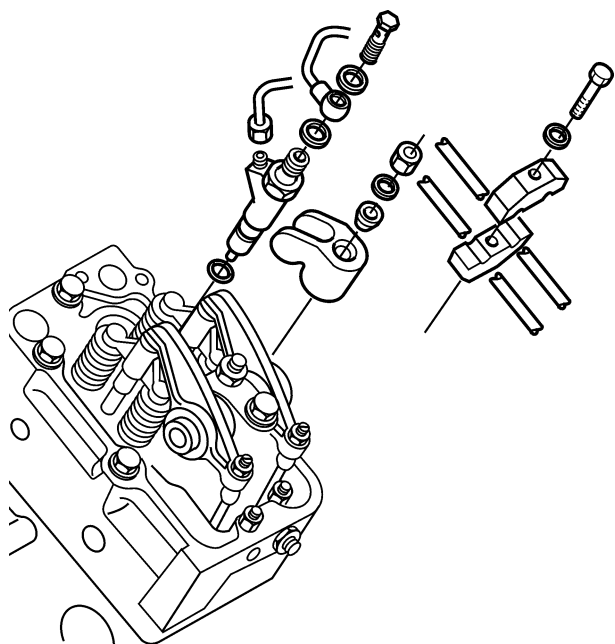

Fuel injection nozzle installation

1. Attach a nozzle gasket to the fuel injector nozzle.
2. Insert the fuel injector into the cylinder head.
3. Install the nozzle gland and tighten the nut to 78 Nm (8.0 kpm) [58 lbf].

Use new sealing washers when securing the fuel injection pipe and fuel return pipe.

4. Tighten the fuel return hollow screw to 15 - 20 Nm (1.5 - 2 kpm) [11 - 15 lbf.ft].
5. Before mounting the rocker cover, operate the engine at approx. 700 rpm and check for fuel leaks. Install the rocker cover.

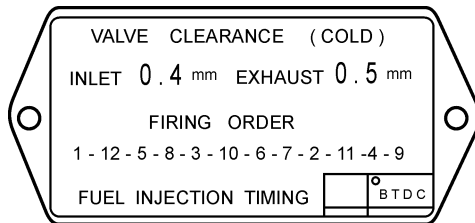

Injection timing inspection

The injection timing is indicated on the caution plate attached to the No. 1 rocker cover. Check it before inspection. Bring the piston for No. 1 cylinder to top dead center on compression stroke as follows:

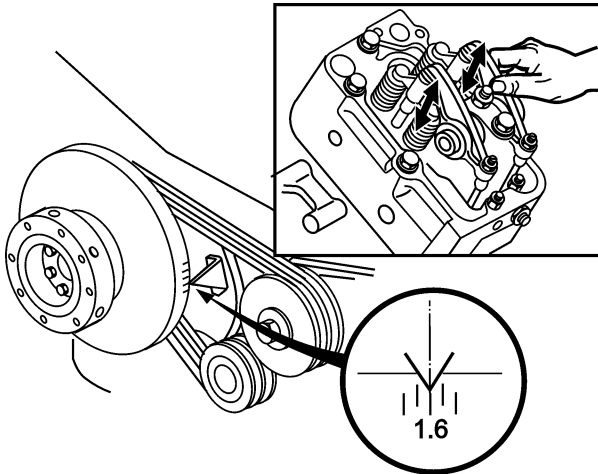

1. Turn the engine in the normal direction to align the timing mark [1.6] on the damper with the pointer as shown.
2. Remove the No. 1 rocker cover and make sure the inlet and exhaust valves for No. 1 cylinder have some clearance. If these valves have no clearance, turn the engine once again to align the timing mark [1.6].

NOTE! Do not confuse the No. 1 cylinder with No. 6. When the piston for the No. 1 cylinder is in the above-mentioned position, its inlet and exhaust valve are seated, presenting some clearance.

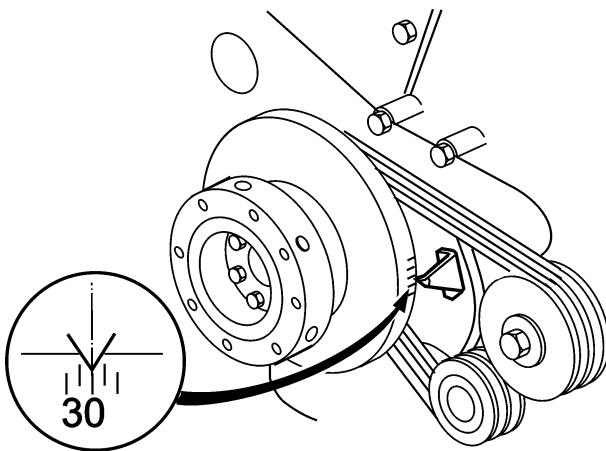

3. Turn back the engine approximately 60 degrees, and turn it in the normal direction slowly until the specified timing (indicated on the caution plate) aligns with the pointer.

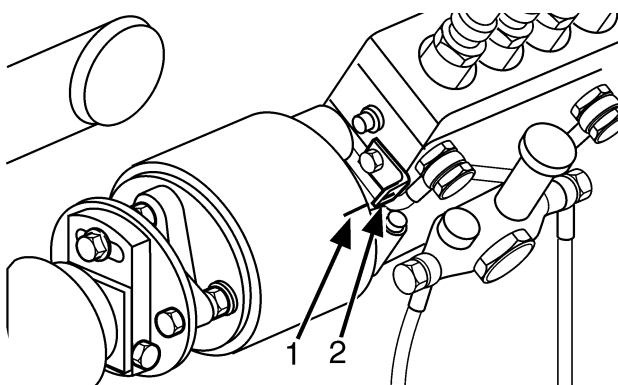

4. To ensure proper injection timing, make sure that the timing mark (1) on the fuel pump flywheel aligns with the pointer (2) on the fuel injection pump.

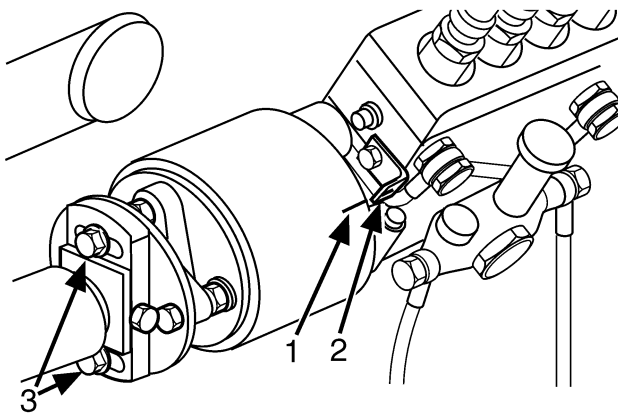
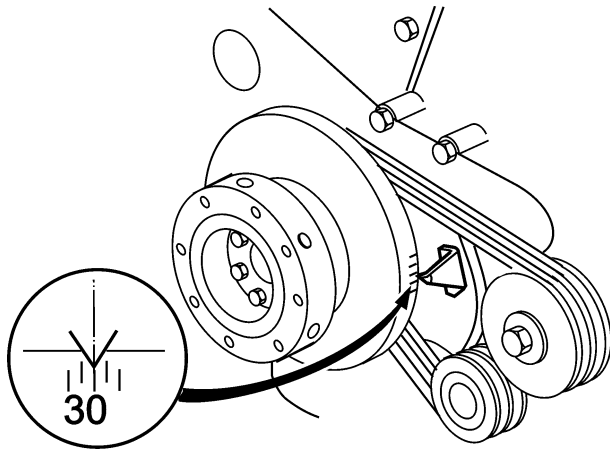

Adjusting fuel injection timing

1. Make sure the timing mark (indicated on the caution plate) is aligned with the pointer, with the piston for the cylinder at top dead center on compression stroke.
2. Loosen the bolts(3) for the fuel injection pump coupling.
3. Turn the fuel pump flywheel until the timing mark(1) on the flywheel aligns with the pointer(2) on the fuel injection pump.
4. Tighten the one nut for fuel injection pump coupling. Turn the engine to tighten the other side nut.
5. Turn the engine (two turns) to recheck the injection timing for verification.

Checking fuel control

Fuel control link joints inspection

Check the ball joints for play. If there is more than 0.1 mm [0.004in.] play, replace the ball joints with new ones.

⚠ WARNING! In case of a control link having ball joints that is an integral part of the link, change the link as an assembly.

Injection pump control rack operation

Move the stop lever back and forth a few times and find out if the control rack can be operated smoothly.

⚠ WARNING! If the rack sticks this must be fixed before starting the engine.

⚠ WARNING! Never try to control the engine rpm by moving the manual stop control lever in the opposite direction of the arrow. This can result in serious harm of the installation.

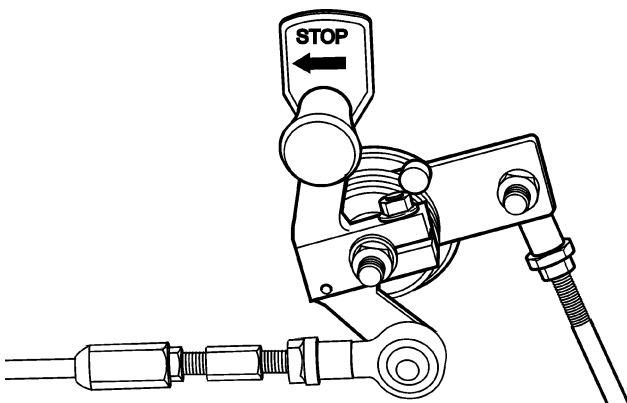

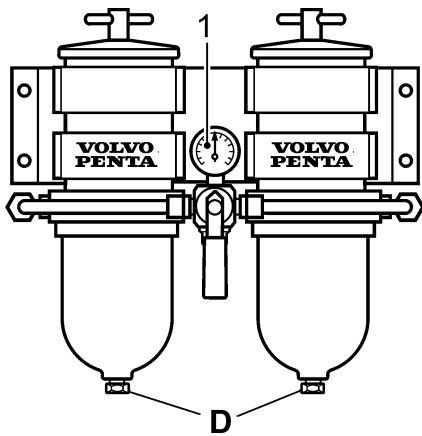

Twin fuel pre-filter/water separator

⚠ WARNING! Working on or approaching a running engine is a safety hazard. Beware of rotating parts and hot surfaces.

The dual filter is equipped with a pressure gauge (1) indicating when it is time to change the filter insert. The filter inserts must be changed according to the maintenance schedule recommendations or earlier if the pressure gauge indicates a vacuum of 6–10 inHg at idling speed or 16–20 inHg at full engine speed/load.

Draining the fuel filter

Place a drip pan under the filter. Drain off water and contaminants through the plug (1) in the bottom of the bowl.

⚠ IMPORTANT! Do not drain until a few hours after stopping.

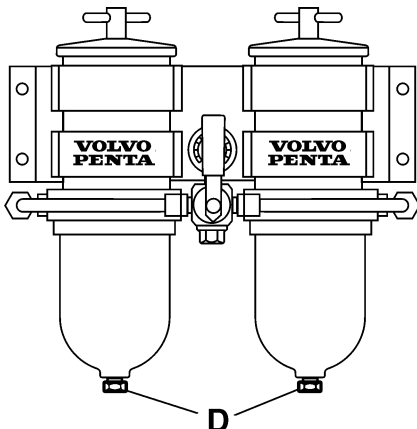

Changing the filter elements

The dual filter inserts can be changed while the engine is running as the flow of fuel can be cut off to one filter container at a time.

The flow of the fuel is governed by turning the handle (1) in the following positions:

- A: Normal running (both filters connected).
- B: Left filter insert can be changed.
- C: Right filter insert can be changed.
- D: Both filters turned off.

If the engine is not running close the fuel cocks on the tank before changing filters. If the engine is running cut off the flow of fuel with the handle (1) on the filter itself.

⚠ WARNING! Working on or approaching a running engine is a safety hazard. Beware of rotating parts and hot surfaces.

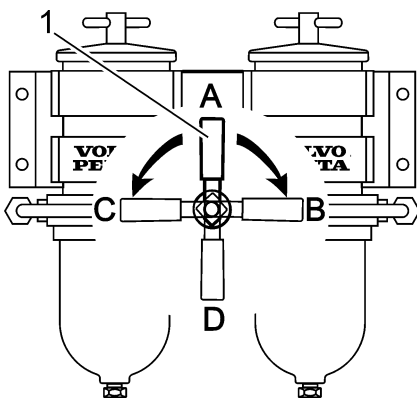

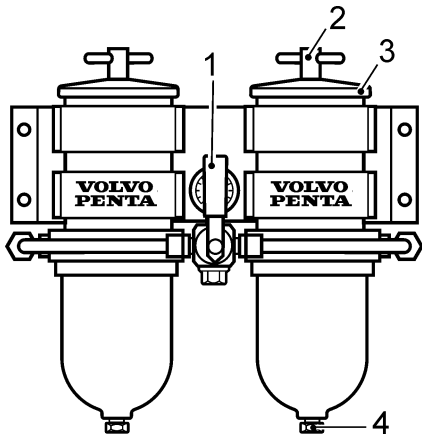

1. Place a drip pan under the filter.
2. Undo the T-bolt (2) and remove the cover (3).
3. Take out the insert carefully while turning it.
4. Drain off water and contaminants through the drain plug (4).
5. Fit a new filter insert and fill the container with clean fuel.

⚠ IMPORTANT! Cleanliness! No contaminants must be allowed in the fuel system.

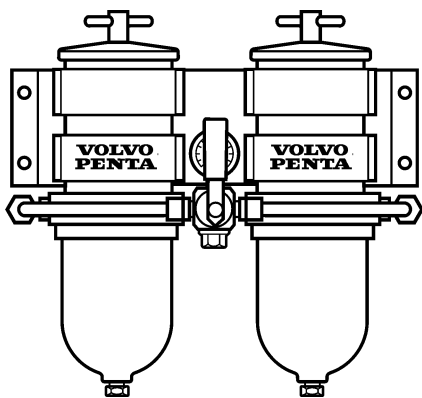

6. Change the gasket on the cover and the O-ring on the T-bolt. Moisten the gasket and O-ring with fuel before assembling.
7. Fit the cover and tighten it by hand.
8. Wipe off any fuel from the filter cover and housing.
9. Dual filter: Change the other filter insert in the same way.
10. Open the fuel cocks and turn the handle (1) in position for normal running. Make sure there are no leaks.

Air inlet and exhaust systems

Turbocharger inspection

⚠ WARNING! Check the turbocharger only when the engine is cool and the compressor wheel is not rotating.

Check shaft play, take a hold of the compressor wheel nut and turn the wheel to feel rattle and listen for abnormal noise. Replace the bearings if the wheel is noisy or rattles.

NOTE! Also check the turbocharger when the exhaust color is abnormal.

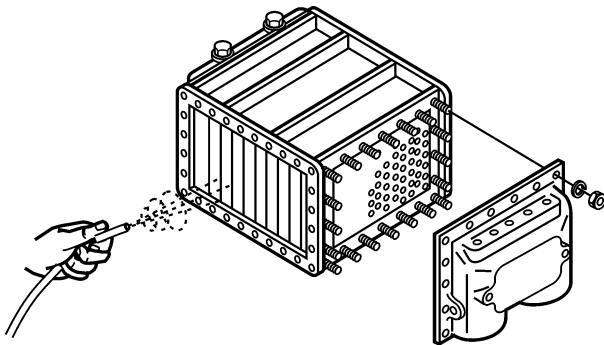
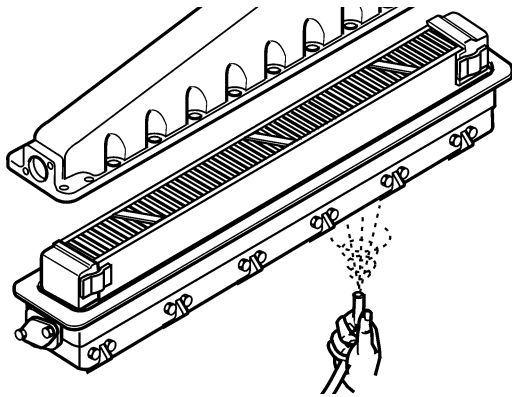

Cleaning the air cooler

1. Remove the air cooler.
2. Blow compressed air through the air cooler in the direction opposite to normal air flow. Max press. is 0.49 MPa (5kpm) [71 psi].
3. Check cooler for corrosion and cracks.
4. Wash the fresh water tubes in water then remove scale deposits by inserting an 8 mm bar into each tube.
5. Replace zinc rods if sea water is used in the cooler.

Checking air cooler drain pipe

Make sure the drain from the air cooler is not clogged.

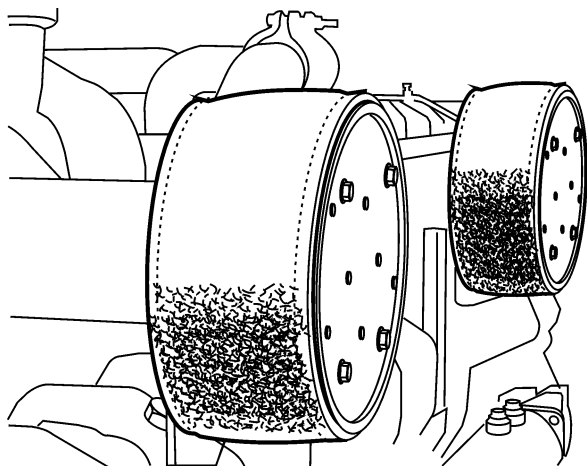

Washing the air inlet silencer filter

Remove dust from the air filters on the suction side of the turbocharger silencers. Be sure to keep the air filters clean to ensure optimum engine performance.

1. Remove the air filter from the silencer, and hand-wash with a mild detergent.
2. Rinse the air filter with clean water.
3. After drying thoroughly, reinstall the air filter in the silencer.
4. Repeat the procedure on the other airfilter.



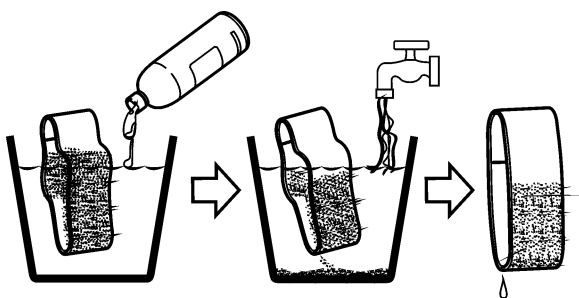



NOTE! If the air filter is damaged it must be replaced.



Cooling system, general

The freshwater system is the internal cooling system of the engine. It is a closed system and shall always be filled with coolant that protects the engine from internal corrosion and frost damage if the climate requires it. Anti-corrosive additives become less efficient with age and the coolant must therefore be changed in accordance with the recommendations in the maintenance schedule.

The rawwater system can be connected to seawater or a central cooling system.

-  **WARNING!** Never open the pressure cap or drain the cooling system when the engine is warm. Steam or hot fluid may spurt out.
-  **WARNING!** The coolant is dangerous to your health and an environmental hazard. Handle coolant with care and dispose of old coolant in accordance with local regulations.
-  **IMPORTANT!** For coolant specification, refer to chapter “Technical data: Coolant specification” in the back of this manual.
-  **IMPORTANT!** Check the coolant level on a cold stationary engine.
-  **IMPORTANT!** Coolant to be added should have the same concentration as the coolant in the engine. Do not add plain water.
-  **IMPORTANT!** Certain parts of the system are made of light alloy. Chemical additives must therefore not be used when cleaning the system.

Cooling system D34 MS HE

The thermostat regulated freshwater system is cooling the lubrication oil coolers, the engine and the charge air coolers. An engine driven cooling water pump circulates the coolant through the heat exchanger and through the engine.

The rawwater system cools the internal cooling system via an engine mounted heat exchanger.

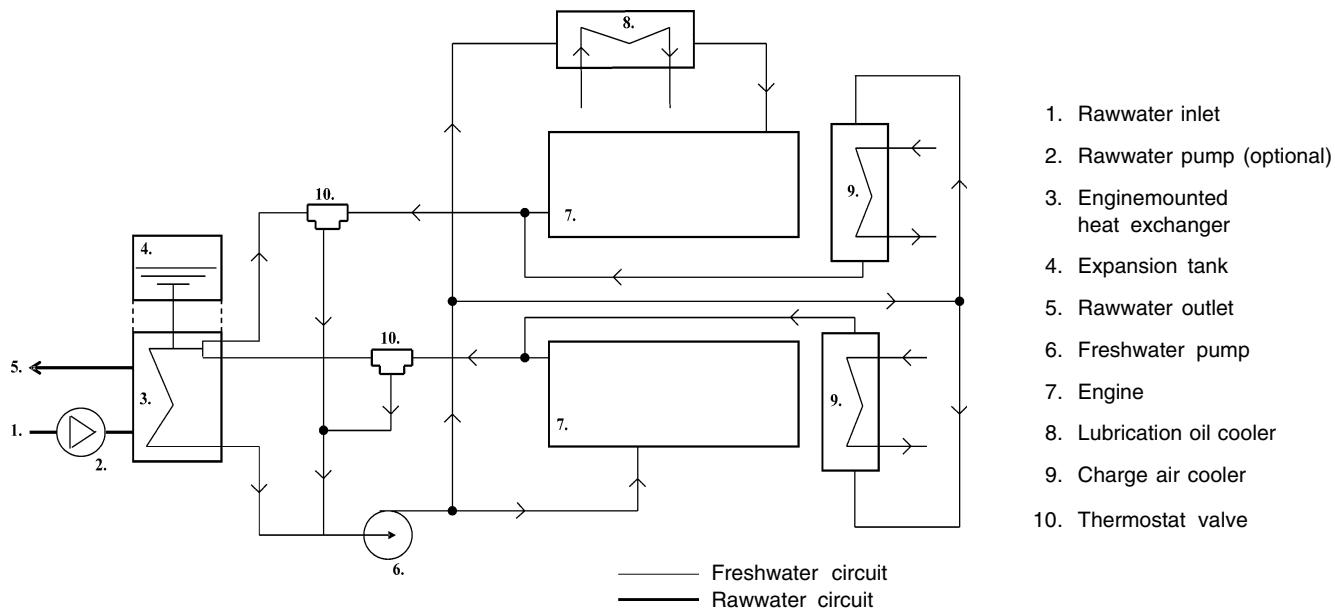

Freshwater drain points (D)

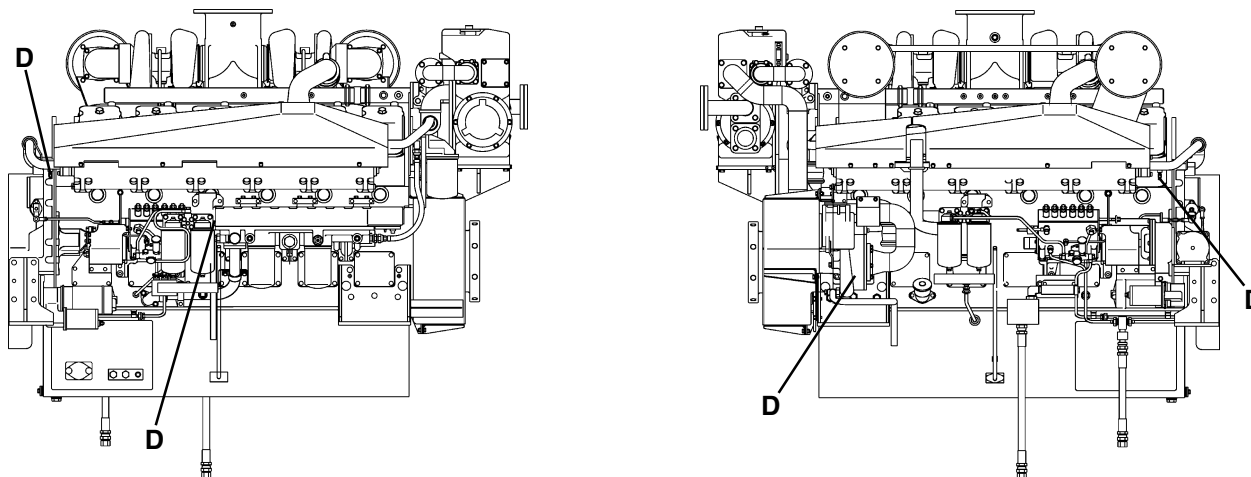

Cooling system D34A MS RC

The thermostat regulated freshwater system is cooling the complete engine. The engine cooling water is cooled by a radiator in a one-circuit cooling system.

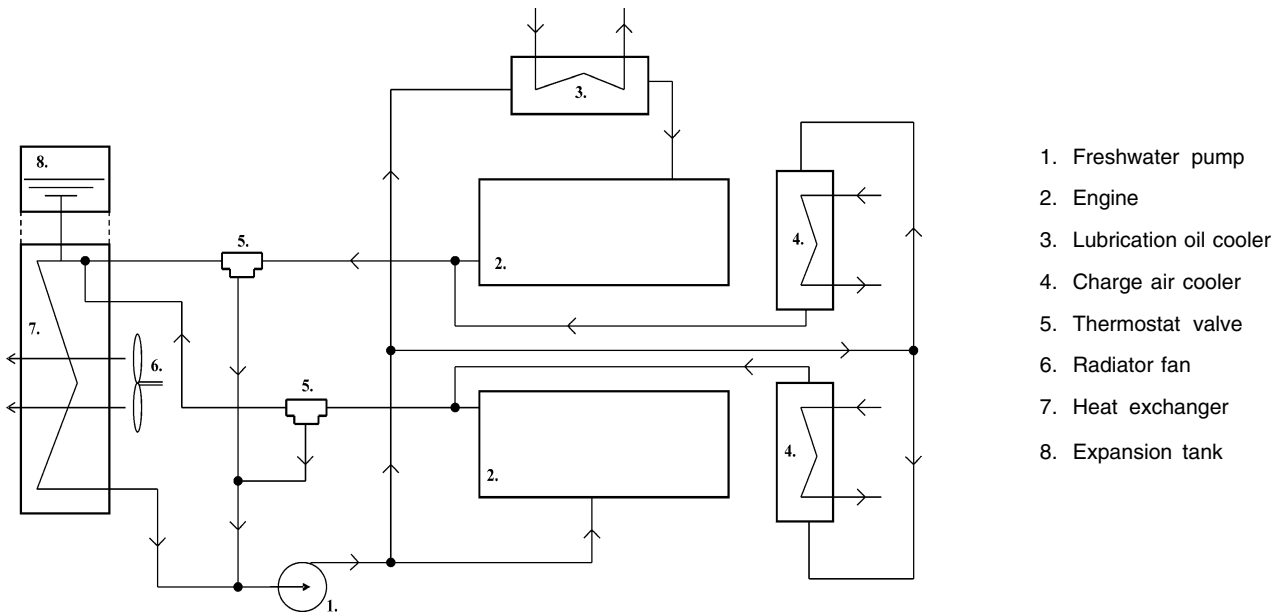

Freshwater drain points (D)

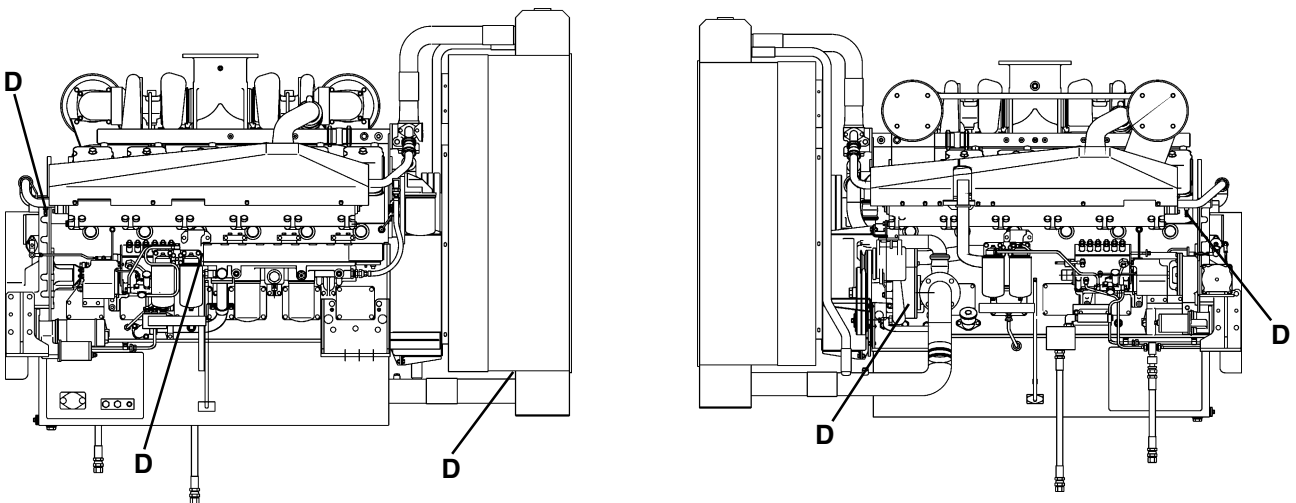

Cooling system D34A MS KC

The engine cooling water is cooled by, e.g. a box cooler, a grid cooler, or any other external heat exchanger. The same coolant (fresh water) is cooling the complete engine.

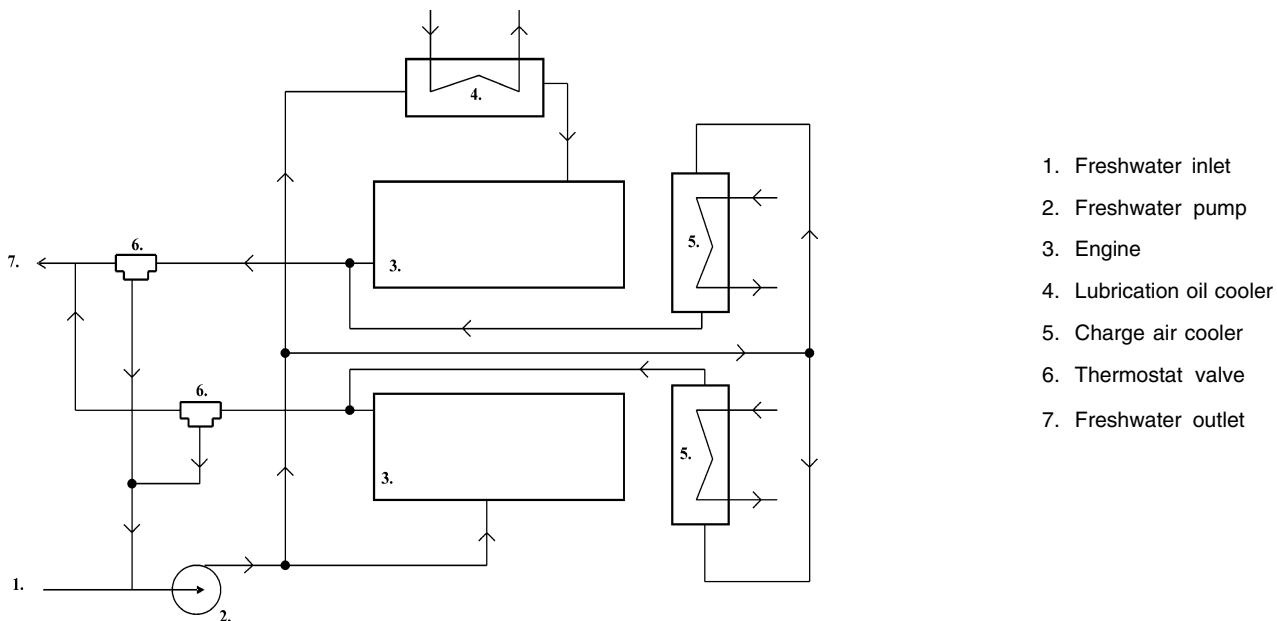

Freshwater drain points (D)

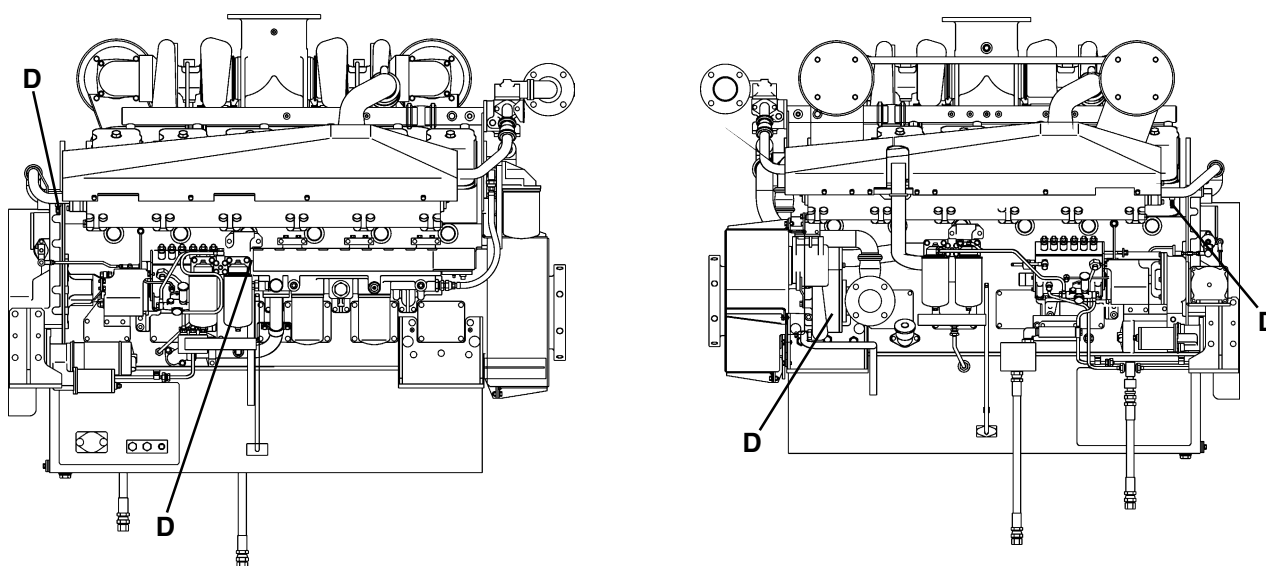

Cooling system D34A MT HE

The thermostat regulated freshwater system is cooling the engine and the lubrication oil cooler. An engine driven cooling water pump circulates the coolant through the heat exchanger and through the engine.

The rawwater system is cooling the charge air and the coolant in the freshwater cooling system. The raw water circuit is designed for raw water cooling or for connection to a central cooling system.

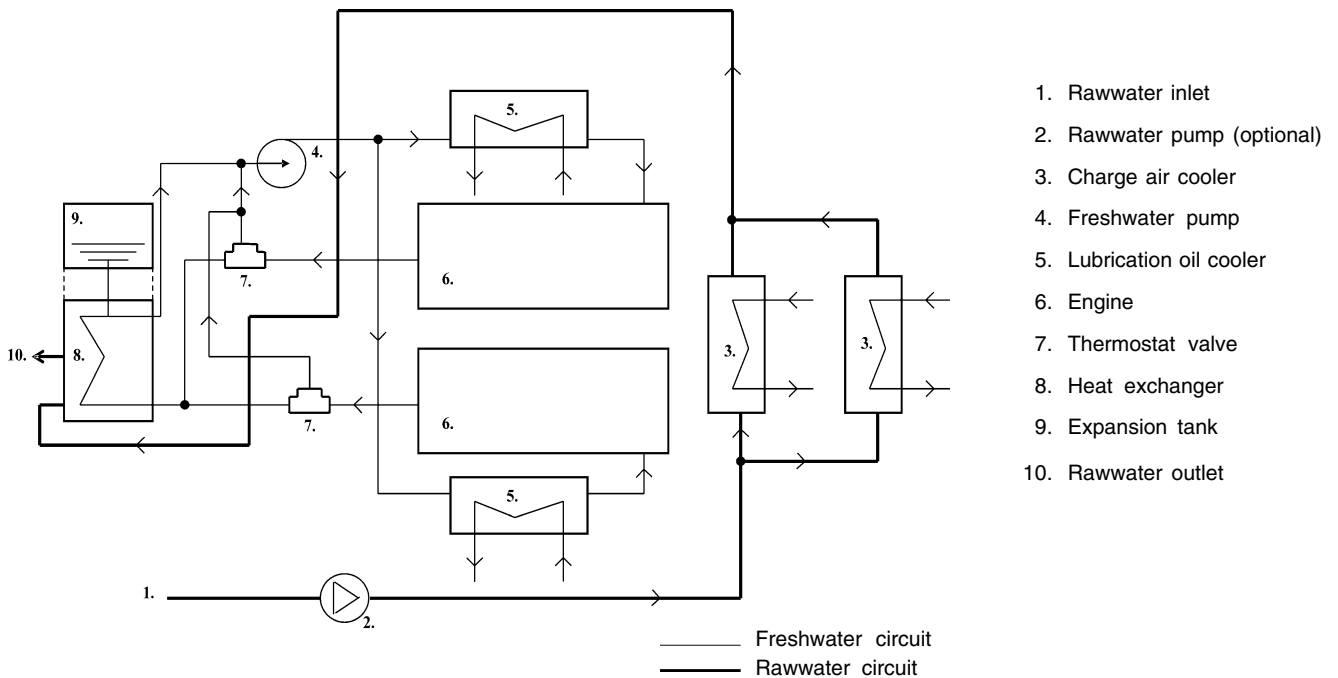

Freshwater drain points (D)

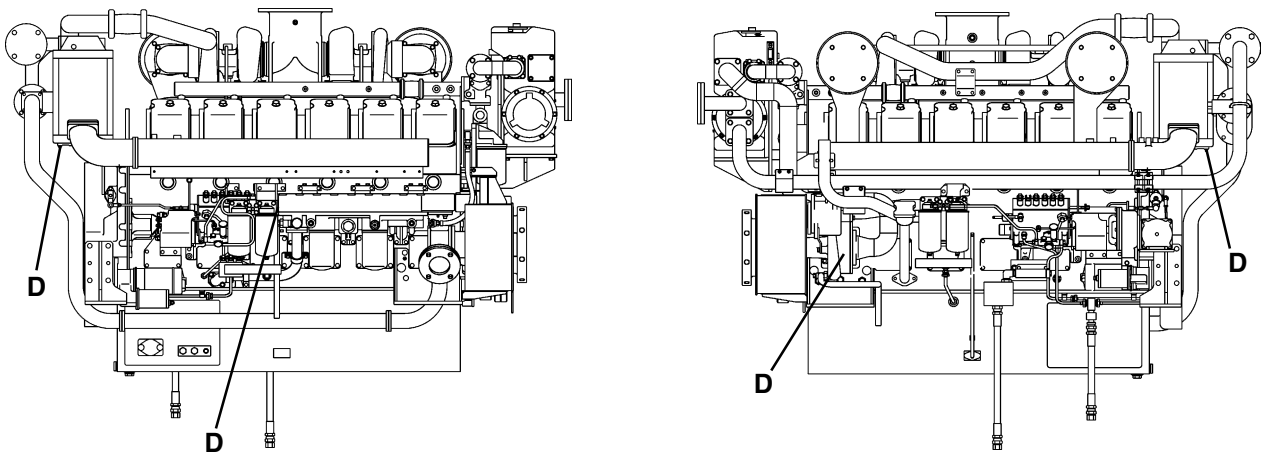

Cooling system D34A MT KC

The thermostat regulated freshwater system is cooling the engine and the lubrication oil cooler. The engine cooling water is cooled by, e.g. a box cooler, a grid cooler, or any other external heat exchanger.

The rawwater system is cooling the charge air.

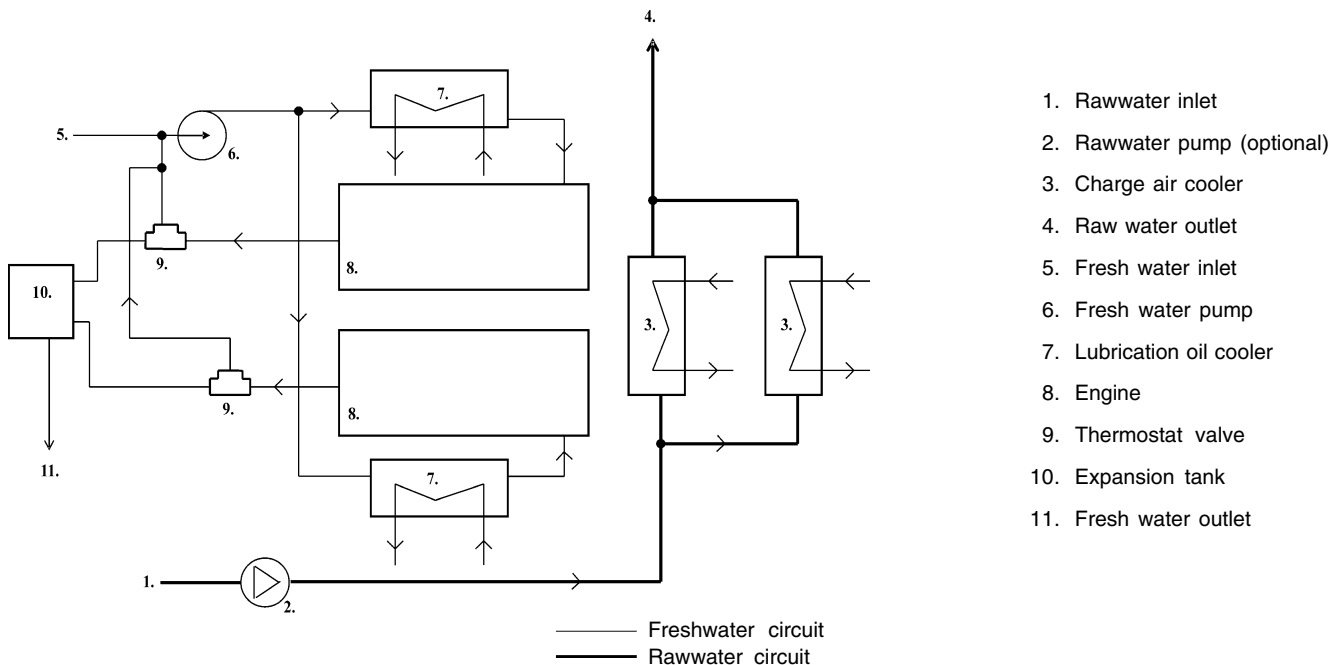

Freshwater drain points (D)

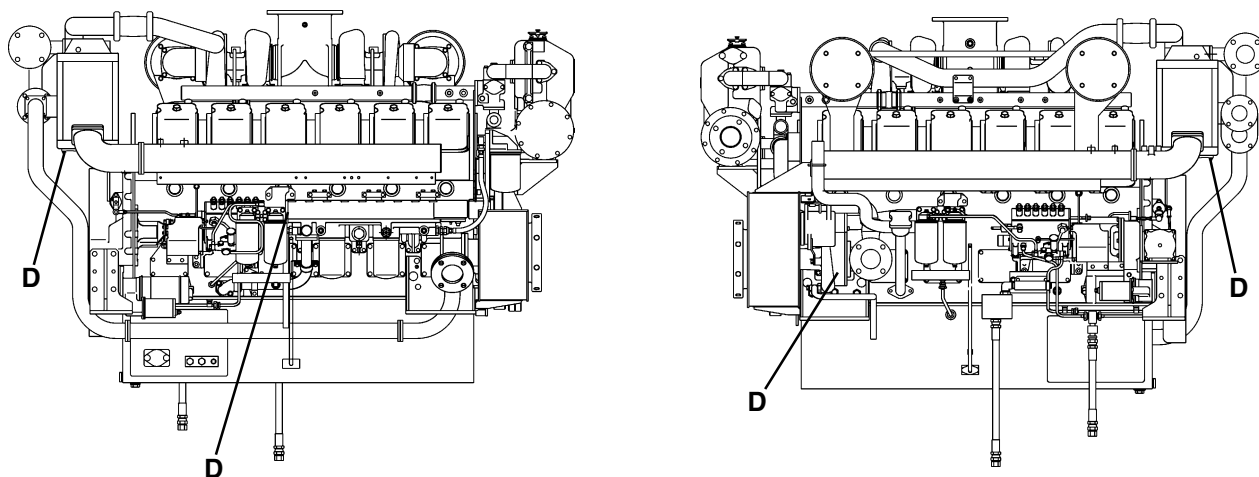

Freshwater system

The freshwater system is the internal cooling system. It is a closed system and must be filled with a coolant that protects the engine from internal corrosion and freezing. Anti-corrosive additives become less efficient with age and the coolant must therefore be changed in accordance with the recommendations in the maintenance schedule.

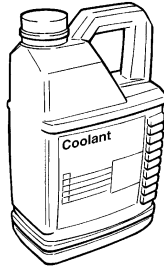

Coolant. General information

The freshwater system shall always be filled with coolant which protects the engine from internal corrosion and from frost damage if the climate requires it.

The corrosion protection additives become less effective as time passes, which means that the coolant must be changed.

⚠ IMPORTANT! Never use water by itself as the coolant. Change the coolant as recommended in the maintenance schedule.

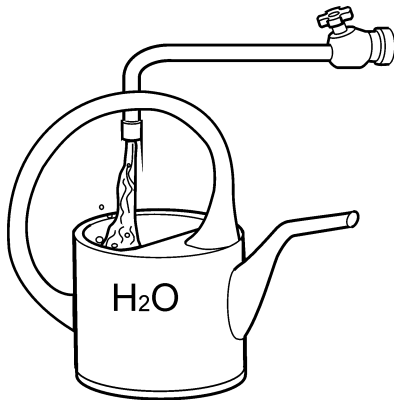

Water quality

The coolant must be mixed with **clean** water complying with ASTM D4985 (see "Technical data: Coolant specification") to avoid any risk of blockage in the cooling system. If there is any doubt about water purity, use **distilled water** or **ready-mixed coolant**.

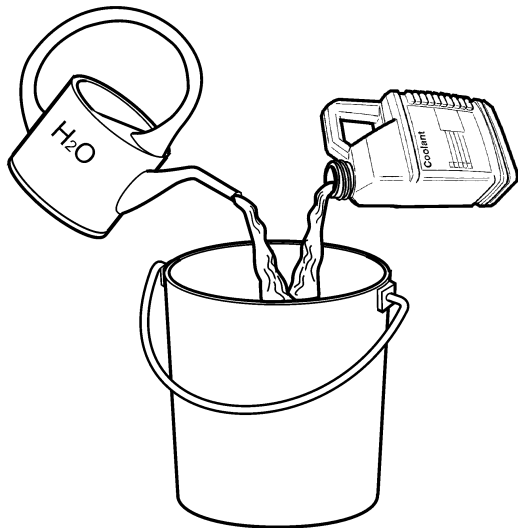

Frost protection mixture

The mixture of Volvo Penta coolant and water should contain 40-55% Volvo Penta coolant. If the mixture contains less than 40% Volvo Penta coolant, the cooling galleries in the engine or radiator may be blocked by contamination. If the coolant contains more than 60% Volvo Penta Coolant the cooling ability of the coolant mixture is impaired, this may cause the engine to overheat. Too high concentration of Volvo Penta Coolant also impairs the frost protection.

⚠ Important! The mixture of Volvo Penta Coolant and water may never contain less than 40% Volvo Penta Coolant.

Corrosion protection mixture

When there is never any risk of frost, water (to ASTM D4985), mixed with Volvo Penta anti-corrosion additive, can be used as a coolant.

We recommend that an anti-freeze mixture should be used all year round, irrespective of the climate.

Mix, following the instructions on the package. Warm the engine up after filling, to give the additive the best effect.

⚠ WARNING! Anti-corrosion additive is poisonous (dangerous to drink).

⚠ IMPORTANT! Never mix anti-corrosion additive with anti-freeze (glycol). This can cause foaming, and severely affect cooling ability.

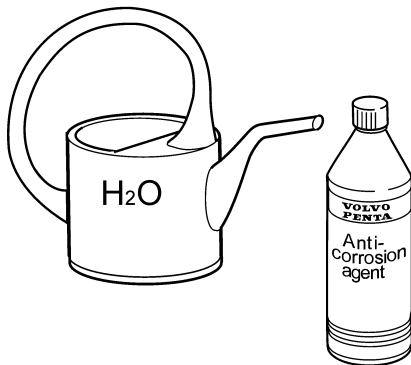

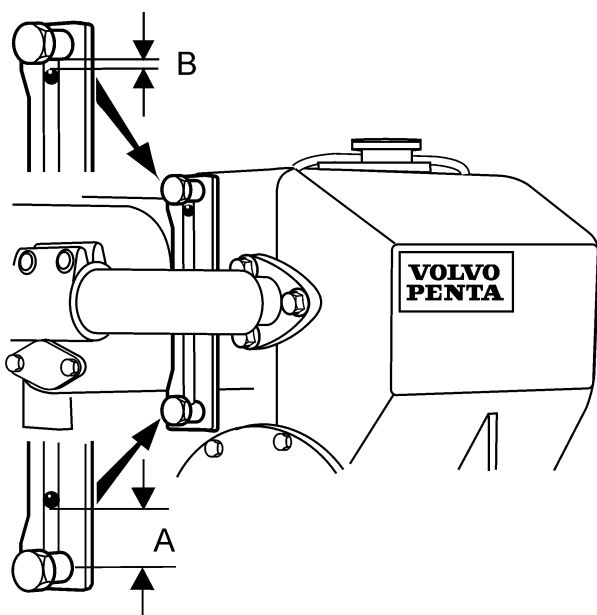

Checking the coolant level

⚠ WARNING! Never open the filler cap when the engine is warm. Steam or hot fluid may spurt out.

⚠ IMPORTANT! Check the coolant level on a cold stationary engine.

MS engines

Make sure the level is between the MIN and MAX marks. If there are no marks, the coolant level should be approximately 5 cm below the top of the filler cap. For coolant specification, refer to chapter “technical data” in the back of this manual.

MT engines

The minimum cooling water level on a cold engine is 175 mm [from the bottom of the sight glass and up (A)].

The cooling water level of a cold engine must never reach higher than 5 mm below the top of the sight glass (B). For coolant specification refer to chapter “technical data”.

Filling the coolant

⚠ WARNING! Stop the engine and allow it to cool down before filling. Hot fluids and hot surfaces can cause burns.

Topping up

Fill the freshwater system with coolant to the correct level through the filler opening in the expansion tank. For correct coolant level, refer to section “Checking the coolant level”. Fill slowly so that the evacuated air is able to pass the filler opening.

Filling when the system is empty

1. Open the air ventilation cocks and close the coolant drain cocks.
2. Make sure that systems connected to the cooling system also are ventilated, e.g. coolers, water heater, etc.
3. Fill the freshwater system with coolant to the correct level through the filler opening in the expansion tank. For correct level, refer to section "coolant level check". Fill slowly letting air bleed from the ventilation cocks and the filler opening. When air-free coolant flows out, close the ventilation cocks.
4. To bleed the system, open all air vent cocks and crank the engine for 10 seconds while holding the emergency stop lever in stop position. Repeat several times at one minute intervals.
5. Close air vents. Check the coolant level and top up if needed.

 **IMPORTANT!** Make sure that the engine is filled with lubrication oil before starting or cranking the engine.

 **IMPORTANT!** The engine must not be started before the system has been bled and topped up.

6. Start the engine and run it under light load until the thermostat valve opening temperature is reached.
7. Check air vents for leaks.
8. Stop the engine and allow it to cool. Check the coolant level in the expansion tank and top up if needed.

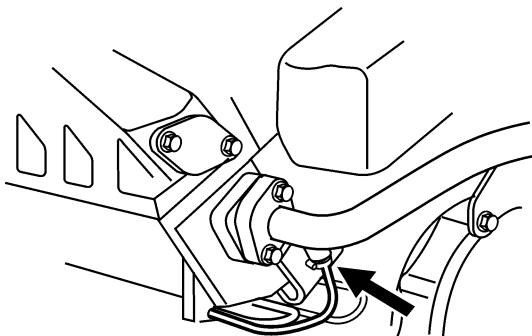
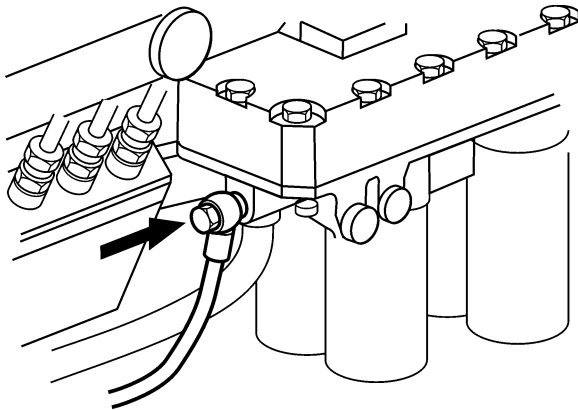
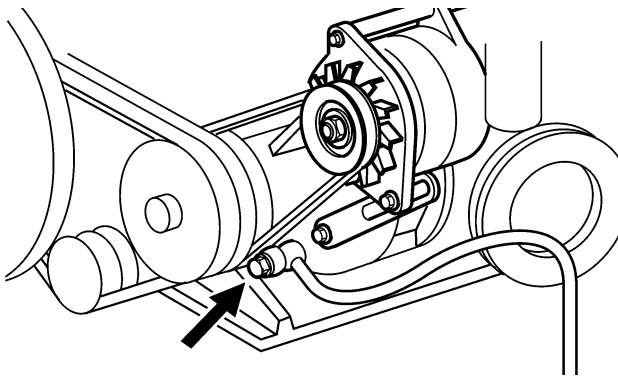

Draining the coolant

1. Remove the filler cap on the expansion tank.
2. Open the air vent cocks and then drain the coolant from the drain cocks.

⚠ IMPORTANT! Check that the coolant really drains. Deposits may need to be removed from inside the drain plugs/taps.

3. Drain all systems connected to the freshwater system, e.g. heater, water heater, etc.
4. Close all drainage points.

Flushing the freshwater system

The system should be flushed before changing coolant to avoid inferior cooling performance due to deposits in the cooling system.

1. Drain the coolant as described earlier.
2. Insert a hose into the filler opening and flush with fresh water.
3. Flush until the water running out of the drainage points is clean.
4. Close all drainage points when the flushing water has run out.
5. Fill with coolant. See section coolant filling when empty.

External cleaning of charge air cooler

(engine with radiator)

1. Remove the required guards to access the radiator.
2. Clean with water and a mild cleaning agent. Use a soft brush. Take care not to damage the cooling vanes.
3. Reinstall the components.



IMPORTANT! Do not use a high pressure hose.

Rawwater system

The rawwater system is the engine's external cooling system. It cools the internal cooling system in an engine mounted or externally mounted heat exchanger. The system is protected against galvanic corrosion by zinc anodes located in the heat exchanger.

Keep the engine room heated or use an antifreeze coolant in the rawwater system. Otherwise the rawwater system must be drained when there is a risk of freezing in cold weather.

⚠ WARNING! The rawwater cocks and/or the cocks of the external cooling system must be closed before commencing work on the rawwater system. This due to the risk of sea water entering the vessel.

Draining the rawwater system

1. Close the rawwater in- and outlet cocks.
2. Drain the coolant from the external cooling system.

⚠ IMPORTANT! Check that the coolant really drains. Deposits may need to be removed from inside the drain plugs/taps.

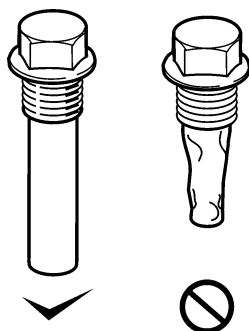

Checking and changing the zinc anodes

Note! Zinc anodes are consumed differently, depending on the marine environment.

1. Drain the external cooling water as described in the chapter draining the rawwater system.
2. Unscrew the zinc anodes from the heat exchanger.
3. Clean the anode with emery cloth to remove the layer of oxide. Change the anode if less than 50% remains.

⚠ IMPORTANT! Do not use a wire brush or other metal tool for cleaning as this may decrease the galvanic protection.

4. Fit the zinc anodes. Make sure there is good contact between the anode and the metal goods.
5. Open the rawwater cocks before starting the engine.
6. Check the installation and make sure there are no leaks.

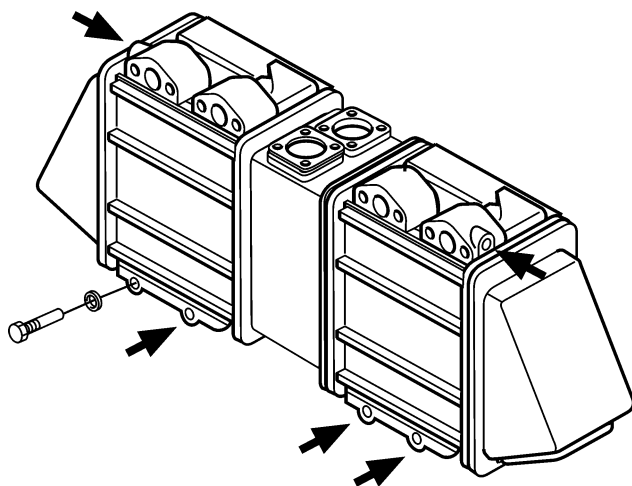

Checking and changing rawwater filter

For the rawwater inlet filter we refer to the maintenance description supplied by the supplier of the filter.

NOTE! If the water wherein the vessel operates is severely polluted, contains large amounts of seaweed, etc., the filter must be checked more often than is specified. The filter can otherwise become clogged and the engine overheated.

Checking and changing rawwater pump impeller

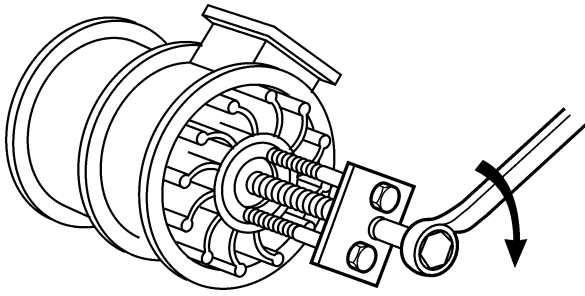

⚠ IMPORTANT! Always keep a spare impeller and gasket in store aboard the ship.

1. Drain the external cooling water as described in the chapter draining the rawwater system.
2. Remove the pump end cover. Remove the impeller using a puller, remember direction of rotation.
3. Inspect the impeller. Change the impeller if there are any visible cracks or other defects.
4. Clean the inside of the housing.
5. Put some grease on the impeller blades and push the impeller into position while rotating it in the normal operating direction.
6. Fit the cover with a new o-ring or gasket.
7. Close the drain cocks.
8. Open the rawwater cocks.

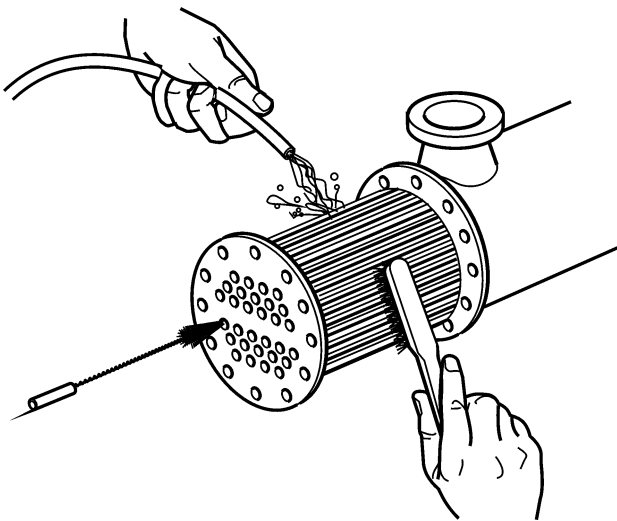

Cleaning heat exchanger

Clean if there are signs of clogging, a gradual increase in engine temperature or high rawwater pressure. Check/clean the rawwater filter first. Also check for other damages on the heat exchanger.

1. Drain the external cooling water as described in the chapter draining the rawwater system.
2. Detach the pipe connections from the heat exchanger.
3. Remove both covers from the heat exchanger
4. Clean the heat exchanger tubes using suitable brushes while flushing the tubes with water
5. Refit the heat exchanger element and mound the covers.
6. Connect the pipe connections to the heat exchanger. Check gaskets and change if necessary.
7. Open the rawwater cocks. Fill the freshwater system.
8. Start the engine and make sure the rawwater system is not leaking.

Electrical system

The engines have a comprehensive electrical engine management system. This automatic system monitors engine speed as well as the electrical and fuel systems and the engine cooling and lubrication functions. The system consists of a number of switches and sensors which activate an alarm or automatic stop (optional) if a fault is detected in the engine.

Supply voltage is 24V.

⚠ WARNING! Before any work is done on the electrical system, the engine must be stopped and the current cut by switching off the battery isolator. Shore current for engine heaters, battery chargers or other auxiliary equipment connected to the engine must be disconnected.

Checking the electrical wiring

Make sure electrical connections are tightened, dry and free from oxide. If necessary, spray these connections with water-repellant (Volvo Penta all-round oil).

Main switches

The main switches must never be turned off until the engine has been stopped. Breaking the circuit between the generator and the batteries while the engine is running can damage the generator. For the same reason, the charge circuits must never be switched while the engine is running.

⚠ IMPORTANT! Never turn the power off using the main switches while the engine is running.

Fuses

The engine is equipped with two circuit breakers which cut the current if overloaded.

The circuit breakers are located in the junction box on the left side of the engine. The circuit breakers are reset by pressing the red button on each breaker, once any faults have been attended to.

NOTE! If the same fuse trips frequently, an authorised Volvo Penta workshop should be contacted to investigate the cause of the overload.

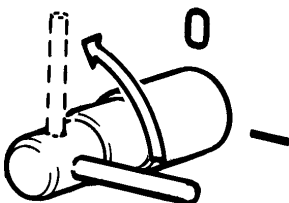

Electric welding

Remove the positive and negative cables from the batteries. Then disconnect all the leads to the generator.

Always connect the welder earth clamp to the component to be welded, and as close as possible to the weld site. The clamp must never be connected to the engine or in such a way that current can pass through a bearing.

⚠ IMPORTANT! When welding has ceased, connect the leads to the generator **before** reconnecting the battery cables.

Batteries

⚠ WARNING! Fire and explosion hazard. Batteries must never be exposed to open flames or sparks.

⚠ WARNING! Never confuse the positive and negative poles on the batteries. Risk of arcing and explosion.

⚠ WARNING! Battery electrolyte is highly corrosive. Always protect your eyes, skin and clothes when handling batteries. Always use protective goggles and gloves. If acid comes into contact with your skin, wash at once with soap and a lot of water. If you get battery acid in your eyes, flush at once with a lot of water, and get medical assistance at once.

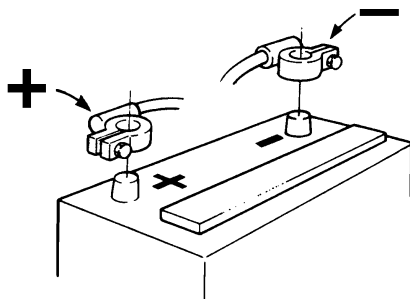

Connection and disconnection

When you connect batteries, first connect the + cable (red) to the + pole on the battery. Then connect the - cable (black) to the - pole on the battery.

When you disconnect batteries, disconnect the - cable (black) first, then the + cable (red).

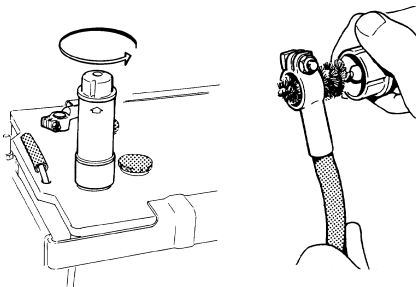

Cleaning

Keep the batteries dry and clean. Contamination and oxide on the batteries and battery poles can cause stray currents, voltage drop and discharge, especially in wet weather. Clean oxidation from the battery poles and terminals, using a copper brush. Tighten the terminals securely and grease them with terminal grease or Vaseline.

Electrolyte level

The electrolyte level should be 5–10 mm (0.2–0.4") above the cell plates in the battery. Top up with battery water as necessary.

After topping up, the batteries should be charged by connecting them to a battery charger, or by running the engine at normal speed for 30 minutes.

NOTE! Some maintenance-free batteries have special instructions, which must be observed.

⚠ IMPORTANT! Never confuse the positive and negative poles on the batteries.

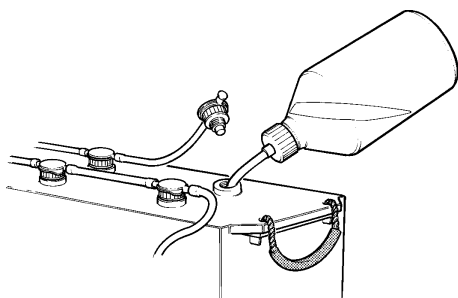

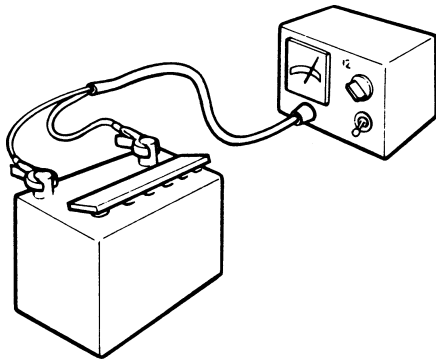

Battery charging

⚠ WARNING! Explosion risk! Hydrogen is given off when batteries are charged. This forms an explosive mixture with air. A short circuit, open flame or spark could cause a violent explosion. Ventilate well.

⚠ WARNING! Battery electrolyte is highly corrosive. Protect your eyes, skin and clothes. Always use protective goggles and gloves. If acid comes into contact with your skin, wash at once with soap and a lot of water. If you get battery acid in your eyes, flush at once with a lot of water, and get medical assistance at once.

Charge batteries if they have become discharged. The batteries will be damaged by being left discharged, and can also freeze and crack in cold weather.

⚠ IMPORTANT! Observe the instruction manual for the battery charger carefully. To avoid the risk of electrochemical corrosion when an external charger is connected, the battery cables in the boat should be removed from the batteries before the charger is connected.

The battery plugs must be unscrewed but left in the holes while charging is in progress. Ventilate well, especially if batteries are being charged in confined spaces.

⚠ WARNING! Always cut the charging current **before** disconnecting the charger cables. Never reverse the polarity of the battery. Risk of sparks and explosion.

Special directions apply for rapid charging. Rapid charging can impair the service life of the batteries and should be avoided.

Control system

System overview

The control and monitoring system consists of the following components:

- Senders and switches
- Electrical box, located on the engine or on a pillar
- Control unit, located on a pillar

All senders and switches are connected to the electrical box. Analogue signals are converted by the AD-card. Alarm switches control alarm indications in the control unit. Shutdown switches, together with the shutdown unit, control emergency stopping of the engine if necessary. The engine is controlled manually by the DCU 305 or by external controls. It can also be connected to a central alarm system. The control system is classified by all the major classification societies and have at least protection class IP44. The system requires a 24V DC electrical supply and is 2-pole, i.e. it has an insulated return. Extra relay cards can be connected to the control unit if necessary.

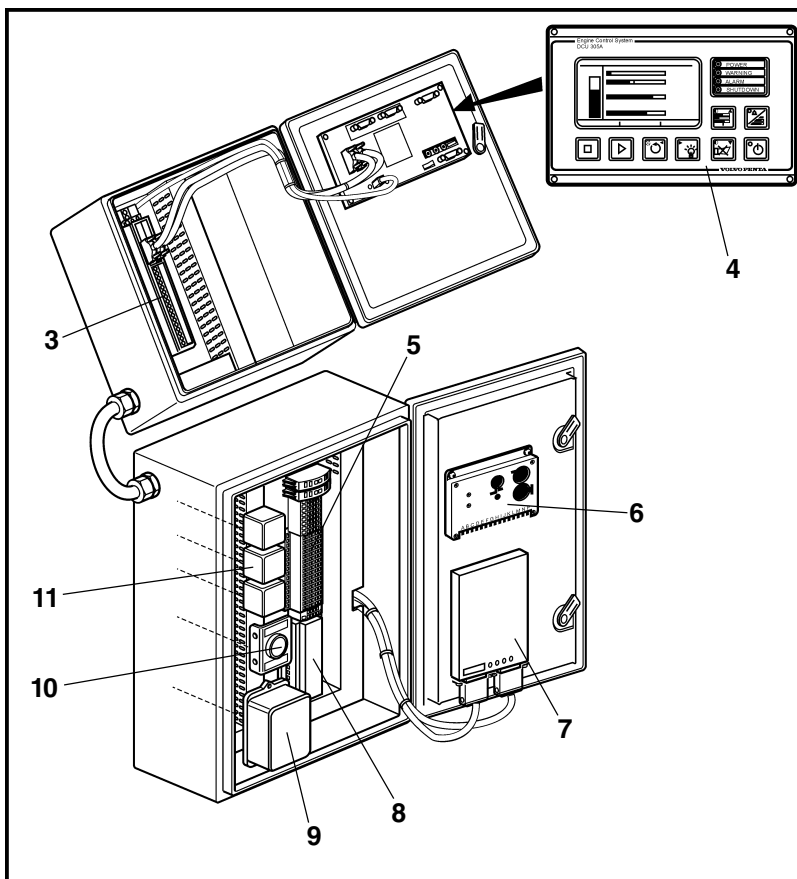

1. Electrical box
2. Control unit
3. RK-66
4. DCU 305 R2
5. Terminal block
6. GAC-unit
7. AD-card
8. Shutdown unit (SDU)
9. Relay box
10. Shutdown reset button
11. Relays

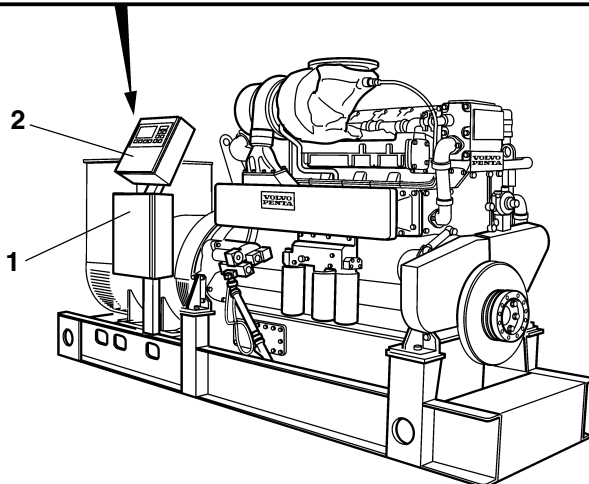

A/D converter

The A/D converter is located on the inside of the electrical connection unit on the engine. A/D conversion stands for analogue to digital conversion of signals. E.g. a temperature signal (analogue) will be converted to a signal that the control unit can handle.

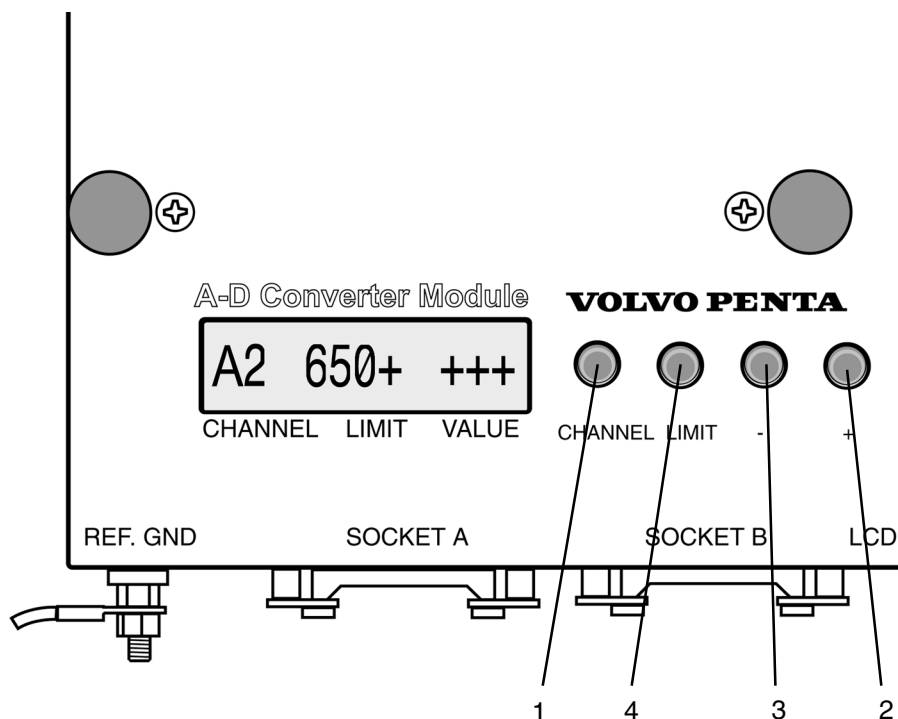

The A/D converter LCD-display shows the signal values before they are transmitted to the control unit.

- Press button "**CHANNEL**" (1) and hold in this position. Simultaneously press the "+" button (2).
- After 1–2 sec. the display will change over to next channel. Release the buttons when the desired channel appears.
- To go backwards through the channels, press "**CHANNEL**" button (1) and simultaneously "-" button (3).

The converter circuit board contains 24 channels but not all are in use. The following channels are active:

L1–L2, S1–S6, A1–A7

Channel L1–L2 are analogue to digital inputs.

Channel S1–S6 are not used.

Channel A1–A7 are analogue channels.

Explanation of display figures

The different channels can be divided into two parts.

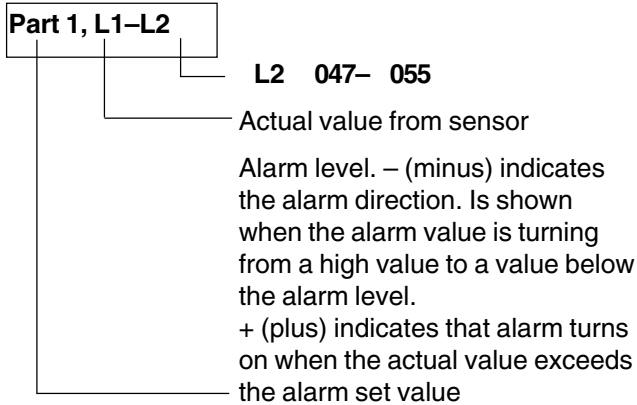

Part 2, A1–A7

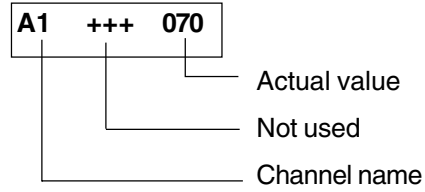

To get an exact information on what the display shows you must know the type of sensors connected to the channel. Sensor type is 4-20 mA, PT100 or PT200. See standard alarm chart.

The A/D-card is programmable in some cases.

Channel name

The two channels L1–L2 are normally set to 4–20 mA sensors.

The figures 047 are equivalent to 4.7 bar. This value represent the pressure and is depending on the pressure range used on sensors.

The figures 055 are equivalent to 5.5 bar.

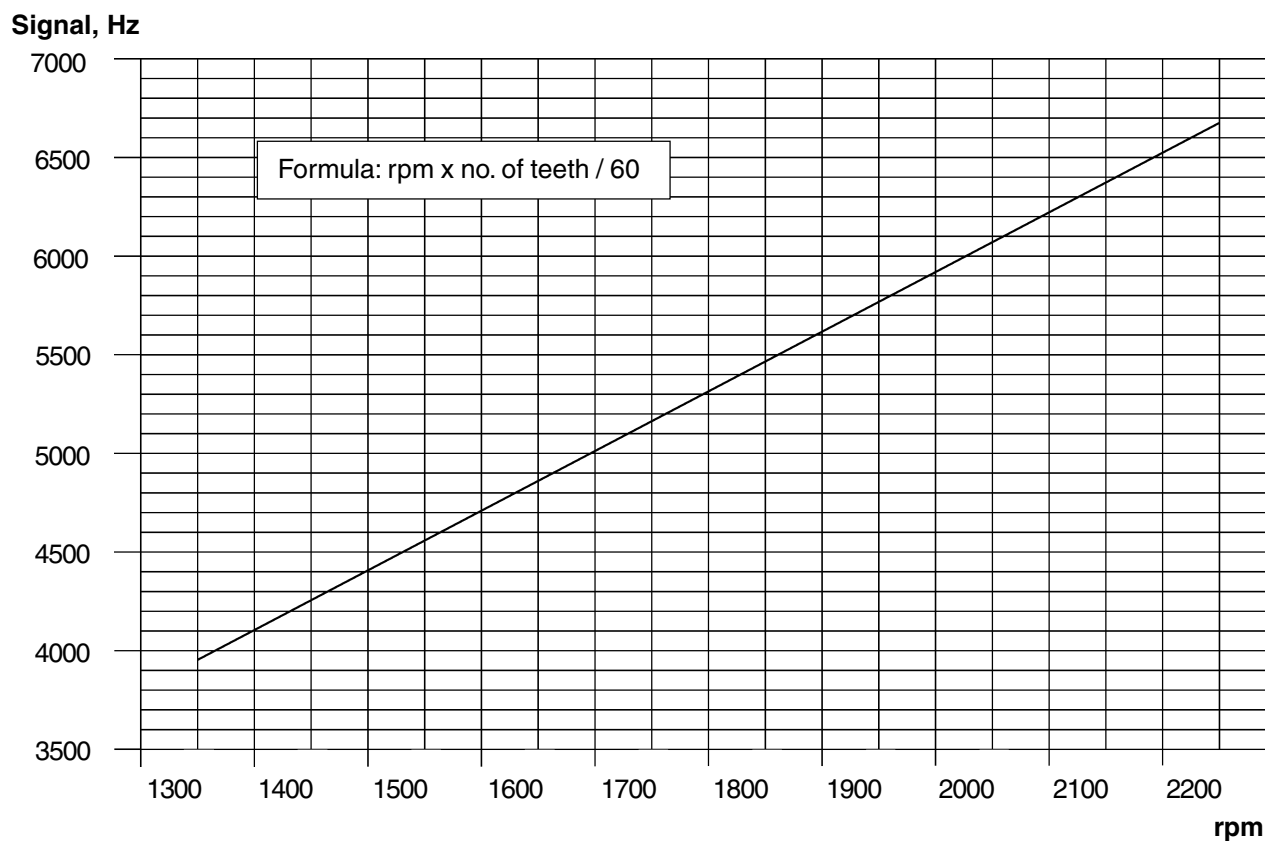
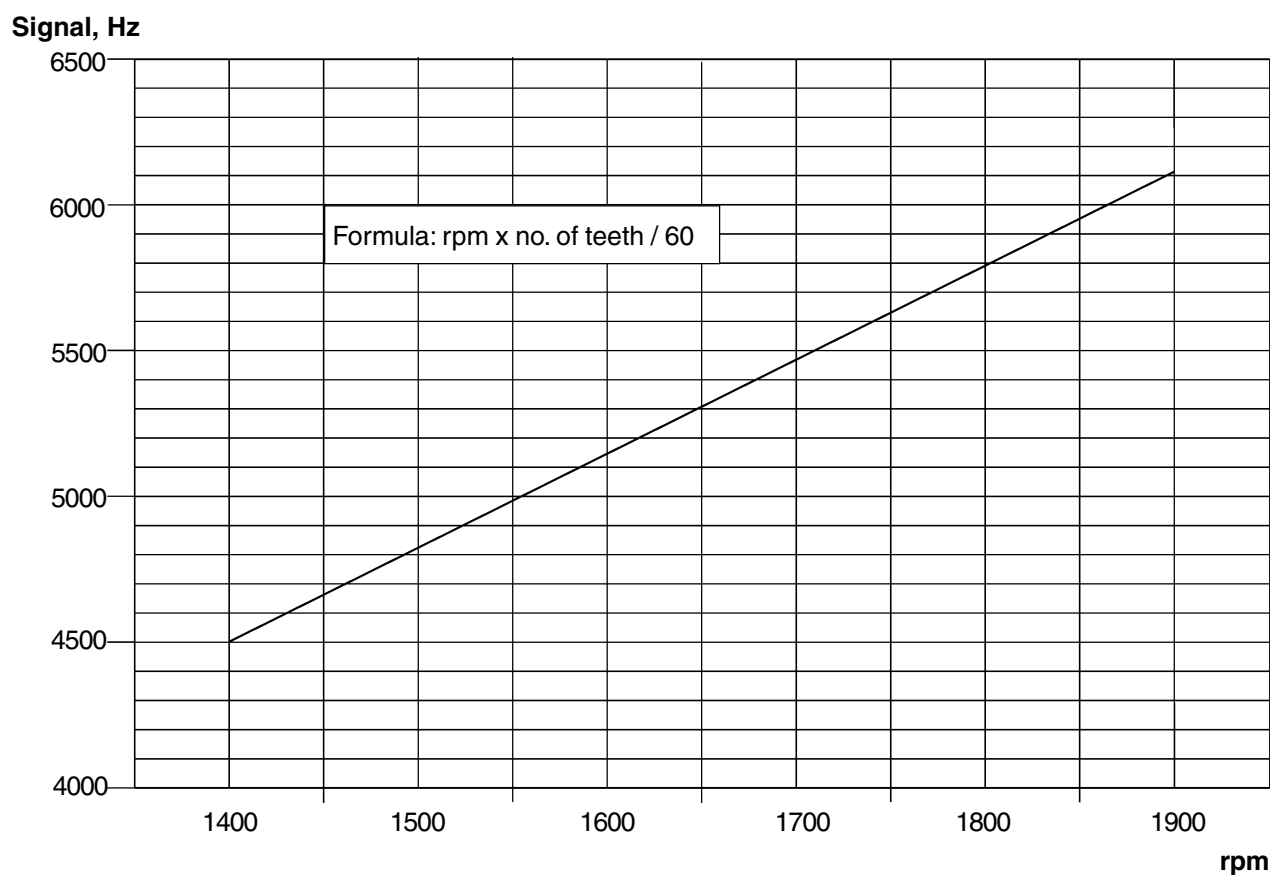
Rpm (engine speed) pickup signal, engine D25, D30, D34**Rpm (engine speed) pickup signal, engine D49, D65**

Temperature sender PT 100

Rsistance, ohm

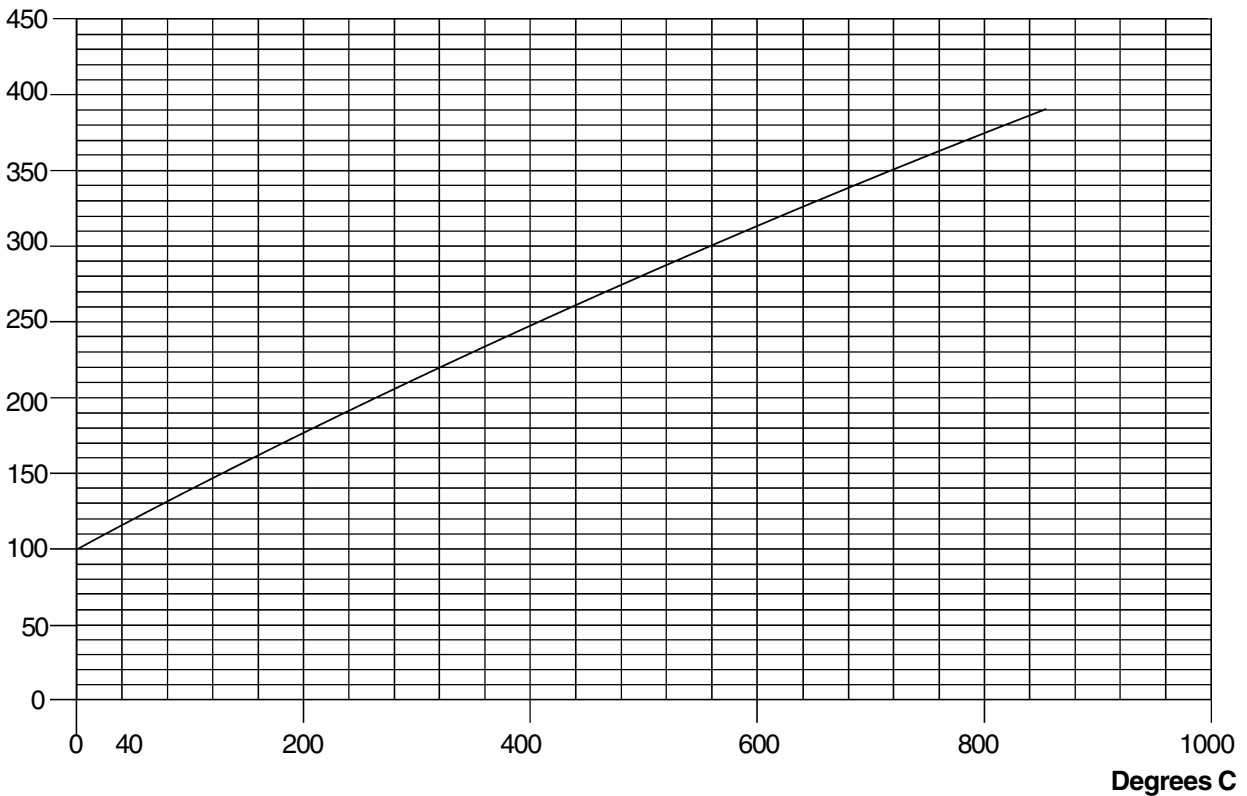

Simulator* for pickup signal (rpm) and temperature signal (PT 100)

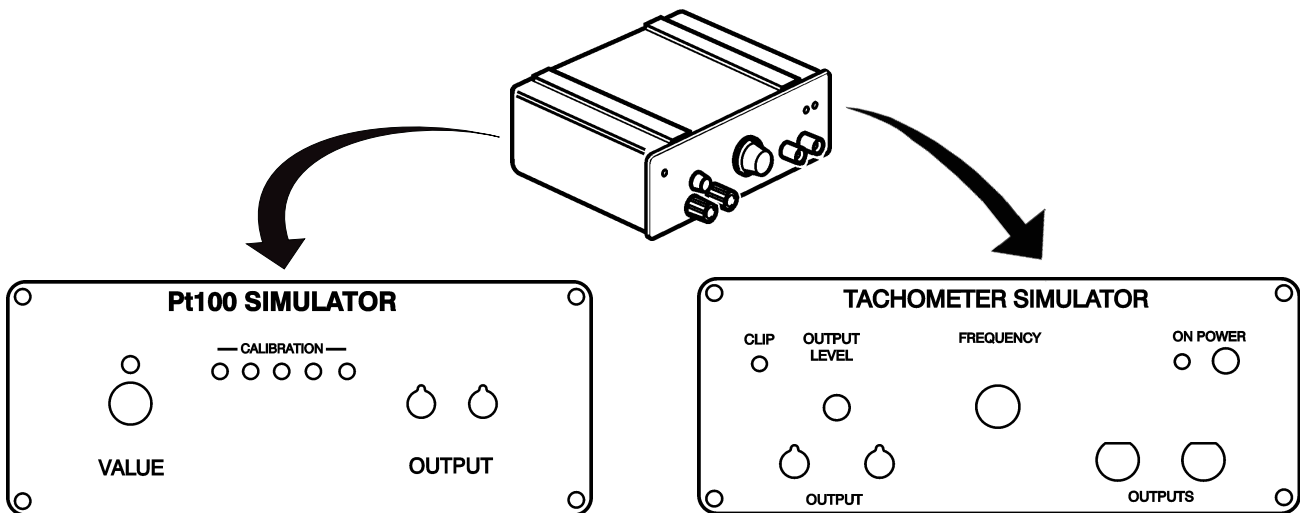

*) Variants of simulators may occur

Test box generating test signals for PT100, temperature signals and simulating engine speed pulses. Replaces engine signals when checking monitoring panel.

Contact Volvo Penta sales engineering dept. for ordering.

Shutdown unit (SDU)

The shutdown unit (SDU) will shut down the engine by cutting off the fuel supply. In **auxiliary mode**, shutdown is enabled for overspeed and for following inputs:

- Coolant water temperature
- Oil pressure
- Coolant water pressure
- Coolant water temperature RH (V-engines)

In **emergency mode**, shutdown is enabled for over-speed only.

Shutdown functions

When above mentioned engine data is not within set limits the SDU will shut down the engine by cutting off the fuel supply. This will trigger an alarm indicated by light and sound on the control panel. The SHUT-DOWN LED indicates that the genset has been stopped. The LED is lit until the engine has stopped completely.

1. Push the ACKNOWLEDGE button to silence the buzzer. The cause of the shutdown will be listed in the alarm list on the LCD screen. A LED on the SDU in the electrical connection box on the engine will also indicate the cause of the shutdown.
2. Rectify the fault.
3. Push the SHUTDOWN RESET button on the electrical connection box on the engine. The LED on the SDU and the lamp on the control panel should go out if the fault no longer exists.
4. Restart the engine.

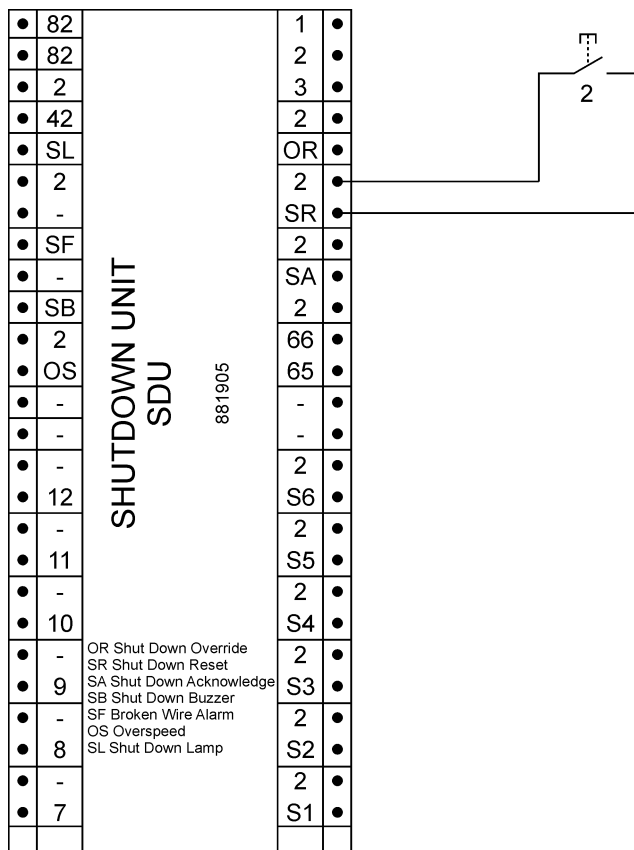

Broken wire

The broken wire detection will set an alarm (light and sound) if the shutdown system should somehow malfunction, e.g. if connection to a switch is lost, or loss of power supply to the shutdown unit itself (the POWER LED on the SDU will no longer be lit in case of power loss).

⚠ IMPORTANT! The BROKEN WIRE function only detect lost connection due to cut off electrical wires, not faulty or loose contacts.

1. Push the ACKNOWLEDGE button to silence the alarm.
2. Check the SDU in the electrical connection box on the engine, a yellow LED corresponding to the broken wire will be lit:

- S1 – Coolant water temperature
- S3 – Engine oil pressure
- S4 – Coolant water pressure
- S5 – Coolant water temperature RH (V-engines)
- SS – Engine rpm
- FV – Fuel shut-off valve

3. Rectify the fault.
4. Push the BROKEN WIRE RESET button (A) on the SDU. If the fault is rectified the LED in the SDU will go out.

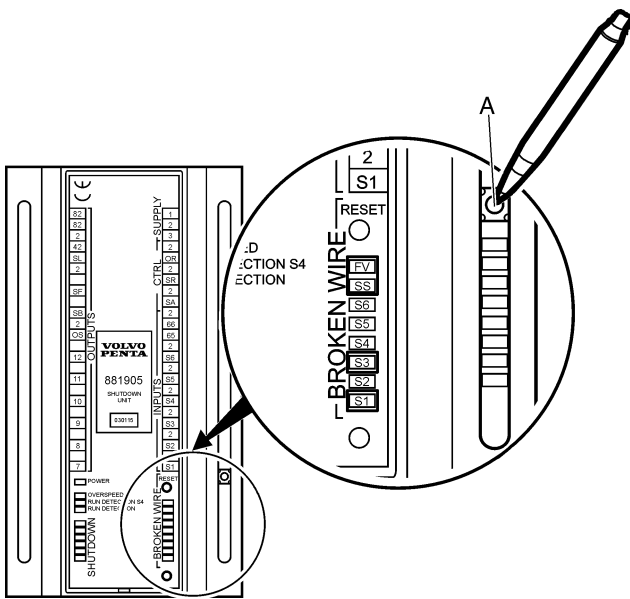

Overspeed shutdown test

On a running engine, open the electrical connection box on the engine and remove the SDU cover. Then push and hold the OVERSPEED TEST button (A). This will lower the overspeed setting by 25% and trigger an overspeed shutdown.

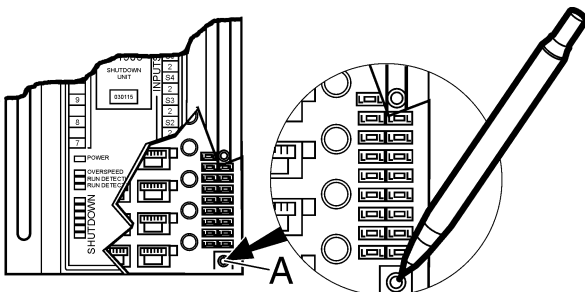

Inhibiting

General

To prevent the genset and other equipment from being harmed during long periods (2 months or more) out of service, it must be conserved. It is of utmost importance that the conservation is performed correctly. Therefore we present this checklist of the most important points. Before taking the engine out of service for long periods, it should be checked by a Volvo Penta dealer for possible needed overhaul or repairs of the engine and other equipment.

⚠ WARNING! Read the chapter "Maintenance" thoroughly before starting any maintenance work. It contains directions for performing maintenance in a safe and correct manner. Certain preservatives are flammable. Some are also dangerous to inhale. Provide good ventilation. Use a protective mask.

⚠ IMPORTANT! The following must be considered when cleaning with a high-pressure water jet: Never point high-pressure water jets directly at seals, rubber hoses or electrical components. Never use the high-pressure function when washing the engine.

⚠ IMPORTANT! For generator specific inhibiting information, refer to generator documentation.

Preparation

1. Drain the lubrication oil from the engine and fill it with new lubrication oil or conserving oil.

⚠ IMPORTANT! Post a warning sign on the engine that the conserving oil must be replaced with the specified lubrication oil before starting the engine again.

2. Run the engine on idling speed on a mixture of 70% fuel and 30% lubrication oil until the complete fuel system is filled with the mixture, then stop the engine (If possible, top up the fuel tank to avoid condensation).
3. When the engine is coming to a stop but is still rotating, spray volatile rust preservative in the air intake and exhaust system. This to prevent rust on the intake system.
4. Apply a coat of rust preservative to the exposed, machined surfaces of the engine.
5. Cover breather, air inlet and exhaust openings with tape.
6. Loosen the alternator and water pump drive belts.
7. Tape the starter and alternator terminals and cover the starter and alternator with a polyethylene sheet. Put a desiccant inside the covering.

⚠ IMPORTANT! Never use vinyl sheets for covering. This can result in condensation and harm the installation

8. Remove the batteries and charge them. Clean the terminal posts and coat them with acid free Vaseline. Keep the batteries in a dry, cool place.
9. Cover the engine for weather protection.

⚠ IMPORTANT! Store the engine in a well-ventilated room.

⚠ IMPORTANT! It is not necessary to drain the coolant because it contains coolant conditioner.

Care during storage

Recharge the battery at least once a month.

⚠ IMPORTANT! During longer periods out of operation, the preparations must be repeated every 12 months.

Return the genset to service

1. Remove the covering from the engine.
2. Connect well-charged batteries to the engine.
3. Remove the covering from the starter and alternator.
4. Adjust the alternator and water pump drive belts.
5. Remove all coverings and tapings.
6. Drain the rust preservative from the engine and fill the engine with recommended engine oil.
7. Fill the fuel tank and prime the fuel system.
8. Check under and around the engine for such items as loose or missing bolts, oil, fuel or coolant leaks and repair if needed.

9. Remove the rocker covers and lubricate the valve mechanism.
10. Crank the engine three times, 10 seconds each time, at intervals of one minute, with the fuel supply shut off, to make sure the oil pressure rises properly.
12. Start the engine.
13. Allow the engine to warm up at low idle.
14. When the engine has run long enough to warm up apply the load and bring it to operating speed.

Storage of genset in operating condition

Service the engine once a month in the following manner:

1. Crank the engine two times, for 10 seconds each time, with the starter at intervals of 30 seconds, with the fuel supply shut off.
2. Start and run the engine under no-load condition for 5 to 10 minutes.

⚠ IMPORTANT! If the engine is fitted with a wet exhaust system and the exhaust is situated below the water line the above has to be performed twice a week (if the exhaust is situated above the water line, once a week is enough).

Troubleshooting

A number of symptoms and possible causes for engine disturbances are described in the table below. If faults or hitches arise that you cannot solve alone, you must always get in touch with your Volvo Penta dealer.

NOTE! Dust and foreign particles are the most common cause of excessive wear of parts. When disassembling a component, take measures to prevent dust and foreign particles from entering it.

⚠ WARNING! Read the safety directions for maintenance and service in the chapter "Safety information" before starting any work.

⚠ IMPORTANT! Handle parts carefully. Only use original Volvo Penta spare parts.

Symptoms and possible causes	
Starter motor does not rotate when cranking	1,2,3,4,5,6
Starter motor rotates slowly when cranking	1,2,3,22,48,49
Engine does not start	,8,9,10,11,12,13,14,15,20,21,23,24,28,50,58
Engine is difficult to start	8,9,10,11,12,13,14,15,20,21,23,24,28,50,51
Engine starts but stops again	8,9,10,11,12,13,14,15,20,21,23,24,28,50,51 52,53
Engine does not reach correct operating speed	8,9,10,11,12,13,14,15,18,19,20,21,22, 23,24,25,26,27,28,33,36,53,58
Engine runs unevenly	8,9,10,11,12,13,14,15,16,17,23,24,28,29 51,58
Engine knocks	21,29,52
Engine vibrates	9,17,23,33,34
Engine can not be stopped	2,3,4,6,54
High fuel consumption	13,15,17,19,20,21,25,26,28,30,33
Black or dark gray exhaust smoke	13,15,17,18,19,20,21,28,30
Blue or white exhaust smoke	17,19,20,21,22,30,33,43,44,51,59
High lubrication oil consumption	22,32,33,34,44
Lubrication oil pressure too low	22,31,35,45,46
Coolant temperature too high	26,38,39,40,41,42,43,55
Coolant temperature too low	43
No charge or poor charge	2,3,47,56,57

- | | | |
|--|--|---|
| 1. Defective starter | 21. Improper fuel oil | 42. Defective cooling water pump |
| 2. Flat batteries | 22. Improper lubrication oil | 43. Defective/wrong thermostat |
| 3. Poor contact/broken cables | 23. Air in fuel system | 44. Too high lubrication oil level |
| 4. Main switch turned off | 24. Water/contamination in fuel | 45. Defective lubrication oil pump |
| 5. Control lever not in neutral/control position not activated | 25. Boat abnormally loaded | 46. Defective relief valve |
| 6. A fuse/circuit breaker has blown/tripped | 26. Fouled hull/propeller | 47. Alternator drive belt slips |
| 7. Lack of fuel | 27. Engine speed control wrongly adjusted | 48. Clutch is engaged |
| 8. Blocked fuel filter | 28. Insufficient air supply | 49. Defective bearings or abnormal cylinder friction |
| 9. Defective fuel filter | 29. Too high coolant temperature | 50. Fuel supply pump strainer blocked |
| 10. Blocked fuel pipes | 30. Too low coolant temperature | 51. Very cold engine and lubrication oil |
| 11. Defective fuel pipes | 31. Too low lubrication oil level | 52. Heavy initial load |
| 12. Blocked fuel supply pump | 32. Lubrication oil leakage | 53. Propeller/propeller shaft blocked |
| 13. Defective fuel supply pump | 33. Worn cylinder liners and/or piston rings | 54. Engine consume lubrication oil or combustible gas |
| 14. Blocked fuel injection pump | 34. Worn valve stem seals | 55. Cylinder liner have scalings or such that reduce cooling effect |
| 15. Defective fuel injection pump | 35. Blocked lubrication oil filter | 56. Alternator/Rectifier broken |
| 16. Blocked fuel injection nozzles | 36. Defective/wrong propeller | 57. Faulty governor |
| 17. Defective fuel injection nozzles | 37. Faulty engine mounting | 58. Broken piston |
| 18. Incorrect valve clearance | 38. Too low coolant level | |
| 19. Incorrect fuel injection timing | 39. Air in fresh water system | |
| 20. Low compression pressure | 40. Blocked sea water inlet/pipe/filter | |
| | 41. Circulation pump drive belt slips | |

Technical Data

D34A MS

General

Number of cylinders	12	
Displacement	33,93 liters (2071 in ³)	
Valve clearance*	0,4 mm (0,016") [inlet]	0,5 mm (0,020") [outlet]
Compression pressure at starter motor speed (120 rpm)	2,45 MPa (356 psi)	
Dry weight engine, without oil and coolant, without generator and frame, approx.	HE 3550 kg (7826 lbs) RC 3860 kg (8510 lbs) KC 3400 kg (7496 lbs)	

* Applies to cold engine

Exhaust temperatures:

679 kW @ 1500 rpm

at 25% of ISO Standard Power	305°C (581°F)
at 50% of ISO Standard Power	385°C (725°F)
at 75% of ISO Standard Power	415°C (779°F)
at 100% of ISO Standard Power	435°C (815°F)
at 110% of ISO Standard Power	445°C (833°F)

Exhaust temperatures:

761 kW @ 1800 rpm

at 25% of ISO Standard Power	310°C (590°F)
at 50% of ISO Standard Power	376°C (709°F)
at 75% of ISO Standard Power	409°C (768°F)
at 100% of ISO Standard Power	428°C (802°F)
at 110% of ISO Standard Power	435°C (815°F)

Lubricating system

Oil capacity, approx.

Including oil filters

No engine inclination	140 liters (37,0 US gals)
volume difference min. –max.	28 liters (7,4 US gals)

Oil pressure, hot engine:

at operating speed	0,50-0,64 MPa (71-93 psi)
--------------------------	---------------------------

Cooling system

Freshwater system capacity

including heat exchanger, approx.	HE Not available
.....	RC 260 liters (68,7 US gals)
.....	KC 50 liters (26,4 US gals)

Electrical system

System voltage	24V
----------------------	-----

Battery electrolyte density at +25°C (77°F):

fully charged battery	1,28 g/cm ³ = 0,0462 lb/in ³ (1,24 g/cm ³ = 0,0448 lb/in ³)*
battery recharged at	1,24 g/cm ³ = 0,0448 lb/in ³ (1,20 g/cm ³ = 0,0434 lb/in ³)*

* **Note.** Applies to batteries with tropical acid.

D34A MT

General

Number of cylinders	12	
Displacement	33,93 liters (2071 in ³)	
Valve clearance*	0,4 mm (0,016") [inlet]	0,5 mm (0,020") [outlet]
Compression pressure at starter motor speed (120 rpm)	2,45 MPa (356 psi)	
Dry weight engine, without oil and coolant, without generator and frame, approx.	HE 3850 kg (8488 lbs)	
.....	KC 3700 kg (8157 lbs)	

* Applies to cold or warm engine (stopped)

Exhaust temperatures:

709 kW @ 1500 rpm

at 25% of ISO Standard Power	300°C (572°F)
at 50% of ISO Standard Power	390°C (734°F)
at 75% of ISO Standard Power	430°C (806°F)
at 100% of ISO Standard Power	460°C (860°F)
at 110% of ISO Standard Power	470°C (878°F)

Exhaust temperatures:

828 kW @ 1800 rpm

at 25% of ISO Standard Power	350°C (662°F)
at 50% of ISO Standard Power	385°C (725°F)
at 75% of ISO Standard Power	435°C (815°F)
at 100% of ISO Standard Power	455°C (851°F)
at 110% of ISO Standard Power	460°C (860°F)

Lubricating system

Oil capacity, approx.

including oil filters

No engine inclination	140 liters (37,0 US gals)
volume difference min. –max.	28 liters (7,4 US gals)

Oil pressure, hot engine:

at operating speed	0,50-0,64 MPa (71-93 psi)
--------------------------	---------------------------

Cooling system

Freshwater system capacity

including heat exchanger, approx.	HE 160 litres (42,3 US gals)
.....	KC Not available

Electrical system

System voltage	24V
----------------------	-----

Battery electrolyte density at +25°C (77°F):

fully charged battery	1,28 g/cm ³ = 0,0462 lb/in ³ (1,24 g/cm ³ = 0,0448 lb/in ³)*
battery recharged at	1,24 g/cm ³ = 0,0448 lb/in ³ (1,20 g/cm ³ = 0,0434 lb/in ³)*

* **Note.** Applies to batteries with tropical acid.

Fuel specification

Fuel must comply with national and international standards at the least, e.g.:

JIS KK 2204.	Type1, Type2, Type3
ASTM, D975	No.1-D, No.2-D
BS2869	Class-A1, Class-A2
DIN51601	Diesel-Fuel
ISO8217	DMX-Class

Note! It is necessary to use a fuel that has a pour point suitable for ambient temperature during the operation of the engine. Consult the supplier to select the right type.

Property	Use limit
Flash point	As stipulated by regulation
First distillation point	170°C (338°F) or more
90% distillation point	330 to 380°C (626 to 716°F)
Pour point	6°C (10.8°F) below ambient temperature
Cloud point	Below ambient temperature
Carbon residue (10% residue oil)	0.4 weight % or lower
Cetan number	45 or more
Cetan index (new)	45 or more
Kinematic viscosity	2.0 mm ² /S or more [30°C (86°F)]
.....	8.0 mm ² /S or lower [50°C (122°F)]
.....	10.5 mm ² /S or lower [40°C (104°F)]
.....	16.0 mm ² /S or lower [30°C (86°F)]
Sulfur content	0.2 weight % or lower
Water and sediment	0.1 volume % or lower
Ash	0.03 weight % or lower
Copper plate corrosion (100°C)[212°F], 3h	No. 3 or lower
Specific gravity (15°C/4°C [59°F/39°F])	0.83 to 0.87
Coking test	Not carbonized 100% at 250°C (482°F)
Aromatics content	38 weight % or lower
Particulate contaminant.....	5.0 mg/liter or lower
Asphaltene	0.1 weight % or lower

Lubrication oil specification

Recommended types of engine oil

Use lubrication oil that meets Class CF standard (recommended engine oil). Class CE and CF-4 engine oils are designed for diesel fuel with a sulfur content of less than 0,5% and less than 0,2%, respectively. Since the sulfur content of most Class-A diesel fuel exceeds 0,5%, do not use class CE or CF-4 engine oil when using class-A diesel fuel

⚠ Important! Use of improper or inferior oil can cause excessive wear of bearings and moving parts, thus shortening the engine life. It can also result in sticking of piston rings and seizing of pistons in the cylinders, thus causing major damage.

Selection of oil viscosity

Use the following chart to select appropriate oil viscosity according to the ambient temperature. Recommended oil viscosity is SAE 15W-40 for all seasons.

⚠ Important! Excessively high oil viscosity causes power loss and higher oil temperature, while excessively low oil viscosity results in inadequate lubrication and leakage of combustion gas with increased wear and reduced output as a result.

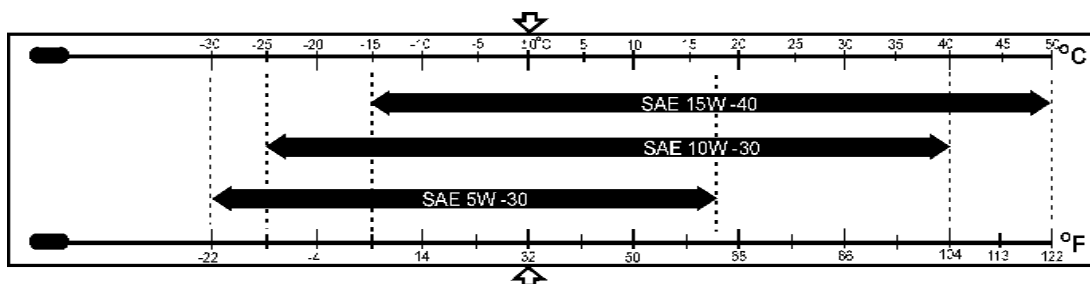

Coolant specification

Always use Volvo Penta Coolant in the freshwater cooling circuit. Volvo Penta Coolant acts both as anti-freeze agent and provides corrosion protection for the metal parts of the cooling system. Future claims might be rejected should Coolant 90 not have been used.

 **Important!** Mixing other types of concentrated coolant with Volvo Penta Coolant, may decrease corrosion protection and may damage the engine or block the cooling system.

Water

Always use clean water that complies with the requirements in ASTM D4985 X1.1. If these requirements are not complied with, corrosion may occur, which would result in impaired cooling performance.

Total fixed particle content.....	< 340 ppm
Total hardness	< 9,5 °dH
Chloride	< 40 ppm
Sulphate	< 100 ppm
pH value	< 5,5 – 9
Silica	< 20 mg SiO ₂ /l
Iron	< 0.10 ppm
Manganese	< 0.05 ppm
Conductivity	< 500 iS/cm
Organic content, COD _{Mn}	<15 mg KMnO ₄ /L

Mixing ratio

The mixture of Volvo Penta Coolant and water should contain 40-55% Volvo Penta Coolant. If the coolant contains less than 40% Volvo Penta Coolant, the cooling galleries in the engine or radiator may be blocked by contamination. If the coolant contains more than 60% Volvo Penta Coolant the cooling ability of the coolant mixture is impaired, this may cause the engine to overheat. Too high concentration of Volvo Penta Coolant also impairs the frost protection.

 **Important!** The mixture of Volvo Penta Coolant and water may never contain less than 40% Volvo Penta Coolant.

Tightening torque table

Important bolts and nuts D34 MS

Description	Thread		Torque			Notes
	Diam.xPitch (M-Thread)	Nm	kpm	lbf.ft		
Cylinder head bolts	20 x 2,5	392	40	289	(a) (b) (c)	
Rocker shaft brackets	12 x 1,75	49	5	36		
Rocker arm lock nuts	12 x 1,25	64	6,5	47		
Valve bridge lock nuts	10 x 1,25	55	5,6	40		
Camshaft gear	30 x 1,5	294	30	216	Left-hand thread	
Camshaft thrust plate	12 x 1,25	59	6	43		
Main bearing caps	24 x 3	588	60	434	(a)(d)	
Main bearing cap side bolts	16 x 1,5	147	15	108	(a)(d)	
Piston cooling nozzles	12 x 1,75	34	3,5	25	(f)	
Timing gear case	12 x 1,75	98	10	72		
Rear plate	12 x 1,25	98	10	72		
Oil pan	10 x 1,5	39	4	29		
Front mounting bracket	20 x 1,5	392	40	290		
Rear mounting bracket	18 x 2,5	245	25	181		
Connecting rod bearing caps	18 x 1,5	343	35	253	(a) (f)	
Flywheel	22 x 1,5	539	55	398	(a)	
Crankshaft pulley and damper	22 x 1,5	539	55	398		
Idler shaft	12 x 1,75	54	5,5	40		
Idler gears	10 x 1,25	39	4	29		
Oil pump drive gear shaft	27 x 1,5	294	30	216		
Oil pump cover	10 x 1,25	26,3-39,7	2,7-4,1	18-32		
Freshwater pump impeller	22 x 1,5	196	20	145		
Freshwater pump pulley	24 x 1,5	245	25	181		

(a) Wet , apply lubrication oil to the threads of the nut and bolt.

(b) 2-step tightening method.

(c) Tighten cylinder head bolts according to the angle method, tighten short bolts to 118 Nm (12 kpm) [86,8 lbf.ft], then tighten 60° more.

(d) Tighten bolts according to the following sequence:

1. Tighten the cap bolts to specified torque
2. Tighten side bolts on the right side of the engine
3. Tighten side bolts on the left side of the engine

(e) Extremely important to use torque wrench in tightening the piston cooling nozzles. Failure to do so may result in excessive tightening torque, which may cause valve malfunctions that could lead to seizing of pistons due to insufficient lubrication.

(f) Tighten connecting rod caps according to the angle method, tighten to 147 Nm [15 kpm][108,5 lbf.ft], then tighten 45° more.

Important bolts and nuts D34 MS

Description	Thread		Torque			Notes
	Diam.xPitch (M-Thread)	Nm	kpm	lbf.ft		
Fuel rack control lever	8 x 1,25	25	2,5	18	(b)	
Injection pump drive gear	30 x 1,5	294	30	216		
Injection pump laminate plate	12 x 1,75	83-93	8,5-9,5	61-69		
Injection pump coupling shaft	14 x 1,5	83-93	8,5-9,5	61-69		
Gland (injection nozzle holder)	12 x 1,25	98	10	72		
Injection nozzle set screw	16 x 1	39-49	4-5	29-36		
Injection nozzle tip retaining nuts	19 x 1	59-78	6-8	43-58		
Exhaust manifolds	10 x 1,5	59-69	6-7	43-51		
Turbocharger compressor wheel (nut)	11 x 1,0	–	–	–	TD10,13(g)(h)(i)	
Turbocharger V-clamp	–	7,8-9,8	0,8-1,0	5,8-7,2	TD10,13 (h)	

(a) Wet , apply lubrication oil to the threads of the nut and bolt.

(b) 2-step tightening method.

(c) Tighten cylinder head bolts according to the angle method, tighten to 294 Nm [30 kpm; 217 lbf.ft], then tighten 60° more.

(d) Tighten bolts according to the following sequence:

1. Tighten the cap bolts to specified torque
2. Tighten side bolts on the right side of the engine
3. Tighten side bolts on the left side of the engine

(e) Extremely important to use torque wrench in tightening the piston cooling nozzles. Failure to do so may result in excessive tightening torque, which may cause valve malfunctions that could lead to seizing of pistons due to insufficient lubrication.

(f) Tighten connecting rod caps according to the angle method, tighten to 245 Nm [25 kpm; 181 lbf.ft], then tighten 60° more.

(g) Left-handed thread.

(h) Apply Moly Disulfide to thread.

(i) Tighten the lock nut to 9,8 Nm [1 kpm][7,2 lbf.ft] then loosen it completely. Retighten to 9,8 Nm [1 kpm][7,2 lbf.ft], then tighten 80±3° more.

Important bolts and nuts D34 MT

Description	Thread		Torque		Notes
	Diam.xPitch (M-Thread)	Nm	kpm	lbf.ft	
Cylinder head bolts	20 x 2,5	392	40	289	(a) (b) (c)
Rocker shaft brackets	12 x 1,75	49	5	36	
Rocker arm lock nuts	12 x 1,25	64	6,5	47	
Valve bridge lock nuts	10 x 1,25	55	5,6	40	
Camshaft gear	30 x 1,5	294	30	216	Left-hand thread
Camshaft thrust plate	12 x 1,25	59	6	43	
Main bearing caps	24 x 3	588	60	434	(a)(d)
Main bearing cap side bolts	16 x 1,5	147	15	108	(a)(d)
Piston cooling nozzles	12 x 1,75	34	3,5	25	(e)
Timing gear case	12 x 1,75	98	10	72	
Rear plate	12 x 1,25	98	10	72	
Oil pan	10 x 1,5	39	4	29	
Front mounting bracket	20 x 1,5	392	40	290	
Rear mounting bracket	18 x 2,5	245	25	181	
Connecting rod bearing caps	18 x 1,5	343	35	253	(a) (f)
Flywheel	22 x 1,5	539	55	398	(a)
Crankshaft pulley and damper	22 x 1,5	539	55	398	
Idler shaft	12 x 1,75	54	5,5	40	
Idler gears	10 x 1,25	39	4	29	
Oil pump drive gear shaft	27 x 1,5	294	30	216	
Oil pump cover	10 x 1,25	26,3-39,7	2,7-4,1	18-32	
Freshwater pump impeller	22 x 1,5	196	20	145	
Freshwater pump pulley	24 x 1,5	245	25	181	

(a) Wet , apply lubrication oil to the threads of the nut and bolt.

(b) 2-step tightening method.

(c) Tighten cylinder head bolts according to the angle method, tighten short bolts to 118 Nm (12 kpm) [86,8 lbf.ft], then tighten 60° more.

(d) Tighten bolts according to the following sequence:

1. Tighten the cap bolts to specified torque
2. Tighten side bolts on the right side of the engine
3. Tighten side bolts on the left side of the engine

(e) Extremely important to use torque wrench in tightening the piston cooling nozzles. Failure to do so may result in excessive tightening torque, which may cause valve malfunctions that could lead to seizing of pistons due to insufficient lubrication.

(f) Tighten connecting rod caps according to the angle method, tighten to 147 Nm [15 kpm][108,5 lbf.ft], then tighten 45° more.

Important bolts and nuts D34 MT

Description	Thread		Torque		Notes
	Diam.xPitch (M-Thread)	Nm	kpm	lbf.ft	
Rawwater pump cam (screw)	10 x 1,25	14-16	1,4-1,6	10-12	
Rawwater pump casing	8 x 1,25	7-8	0,7-0,8	5-6	
Rawwater pump cover	8 x 1,25	7-8	0,7-0,8	5-6	
Rawwater pump pulley (nut)	33 x 3,5	196	20	145	
Fuel rack control lever	8 x 1,25	25	2,5	18	(b)
Injection pump drive gear	30 x 1,5	294	30	216	
Injection pump laminate plate	12 x 1,75	83-93	8,5-9,5	61-69	
Injection pump coupling shaft	14 x 1,5	83-93	8,5-9,5	61-69	
Gland (injection nozzle holder)	12 x 1,25	98	10	72	
Injection nozzle set screw	16 x 1	39-49	4-5	29-36	
Injection nozzle tip retaining nuts	19 x 1	59-78	6-8	43-58	
Exhaust manifolds	10 x 1,5	59-69	6-7	43-51	
Turbocharger compressor wheel (nut)	11 x 1,0	–	–	–	TD10,13(g)(h)(i)
Turbocharger V-clamp	–	7,8-9,8	0,8-1,0	5,8-7,2	TD10,13 (h)

(a) Wet , apply lubrication oil to the threads of the nut and bolt.

(b) 2-step tightening method.

(c) Tighten cylinder head bolts according to the angle method, tighten to 294 Nm [30 kpm; 217 lbf.ft], then tighten 60° more.

(d) Tighten bolts according to the following sequence:

1. Tighten the cap bolts to specified torque
2. Tighten side bolts on the right side of the engine
3. Tighten side bolts on the left side of the engine

(e) Extremely important to use torque wrench in tightening the piston cooling nozzles. Failure to do so may result in excessive tightening torque, which may cause valve malfunctions that could lead to seizing of pistons due to insufficient lubrication.

(f) Tighten connecting rod caps according to the angle method, tighten to 245 Nm [25 kpm; 181 lbf.ft], then tighten 60° more.

(g) Left-handed thread.

(h) Apply Moly Disulfide to thread.

(i) Tighten the lock nut to 9,8 Nm [1 kpm][7,2 lbf.ft] then loosen it completely. Retighten to 9,8 Nm [1 kpm][7,2 lbf.ft], then tighten 80±3° more.

Standard bolts and nuts

Fine threads

Thread diameter x pitch	Strength classification					
	7T			10.9		
mm [in.]	Nm	kpm	lbf.ft	Nm	kpm	lbf.ft
M10 x 1,25 [0.39 x 0.049]	33	3,4	25	60	6,1	44
M12 x 1,25 [0.47 x 0.049]	60	6,1	44	108	11,0	80
M14 x 1,5 [0.55 x 0.059]	97	9,9	72	176	17,9	129
M16 x 1,5 [0.63 x 0.059]	145	14,8	107	262	26,7	193
M18 x 1,5 [0.71 x 0.059]	210	21,4	155	378	38,5	278
M20 x 1,5 [0.79 x 0.059]	291	29,7	215	524	53,4	386
M22 x 1,5 [0.87 x 0.059]	385	39,3	284	694	70,8	512
M24 x 1,5 [0.94 x 0.059]	487	49,7	359	878	89,5	647
M27 x 3 [1.06 x 0.12]	738	75,3	544	1328	135,5	980

Coarse threads

M8 x 1,25 [0.31 x 0.049]	17	1,7	12	30	3,1	22
M10 x 1,5 [0.39 x 0.059]	32	3,3	24	58	5,9	43
M12 x 1,75 [0.47 x 0.069]	57	5,8	42	102	10,4	75
M14 x 2 [0.55 x 0.079]	93	9,5	69	167	17,0	123
M16 x 2 [0.63 x 0.079]	139	14,2	103	251	25,6	185
M18 x 2,5 [0.71 x 0.098]	194	19,8	143	350	35,7	258
M20 x 2,5 [0.79 x 0.098]	272	27,7	200	489	49,9	361
M22 x 2,5 [0.87 x 0.098]	363	37,0	268	653	66,6	482
M24 x 3 [0.94 x 0.12]	468	47,7	345	843	86,0	622
M27 x 3 [1.06 x 0.12]	686	70,0	506	1236	126,0	911

Standard eyebolts

Thread diameter x pitch	Strength classification		
	4T		
mm [in.]	Nm	kpm	lbf.ft
M8 x 1,25 [0.31 x 0.049]	8±1	0,8±0,1	5,8±0,72
M10 x 1,25 [0.39 x 0.049]	15±2	1,5±0,2	10,8±1,45
M12 x 1,25 [0.47 x 0.049]	25±3	2,5±0,3	18,1±2,17
M14 x 1,5 [0,55 x 0.059]	34±4	3,5±0,4	25,3±2,89
M16 x 1,5 [0.63 x 0.059]	44±5	4,5±0,5	32,5±3,62
M18 x 1,5 [0.71 x 0.059]	74±5	7,5±0,5	54,2±3,62
M20 x 1,5 [0.79 x 0.059]	98±10	10,0±1,0	72,3±7,23
M24 x 1,5 [0.94 x 0.059]	147±15	15,0±1,5	108,5±10,8
M27 x 3 [1.06 x 0.12]	226±20	23,0±2,0	166,3±14,5

(Dry)

Standard union nuts

Cap nut size diameter x pitch mm [in.]	Strength classification			Nominal diameter
	Nm	kpm	lbf.ft	
M14 x 1,5 [0.55 x 0.059]	39	4	29	63
M16 x 1,5 [0.63 x 0.059]	49	5	36	80
M20 x 1,5 [0.79 x 0.059]	78	8	58	100
M22 x 1,5 [0.87 x 0.059]	98	10	72	120
M27 x 1,5 [1.06 x 0.059]	157	16	116	150
M30 x 1,5 [1.18 x 0.059]	196	20	145	180
M30 x 1,5 [1.18 x 0.059]	196	20	145	200
M33 x 1,5 [1.30 x 0.059]	245	25	181	220
M36 x 1,5 [1.42 x 0.059]	294	30	217	254

(Dry)

High pressure fuel injection pipes

Cap nut size diameter x pitch mm [in.]	Strength classification		
	Nm	kpm	lbf.ft
M12 x 1,5 [0.49 x 0.059]	39±5	4±0,5	29±3,6
M14 x 1,5 [0.55 x 0.059]	49±5	5±0,5	36±3,6
M18 x 1,5 [0.71 x 0.059]	59±1	6±1,0	43±7,2

(Dry)

Identification numbers

Type plates with identification numbers can be found on the engine and on the generator. This information must always be used as a reference when ordering service and spare parts.

Engine label

Product designation
 Serial and basic engine number
 Product number

Certification, IMO

Decal, part No.
 Approval No.

Generator label

Product designation
 Serial number
 Product number

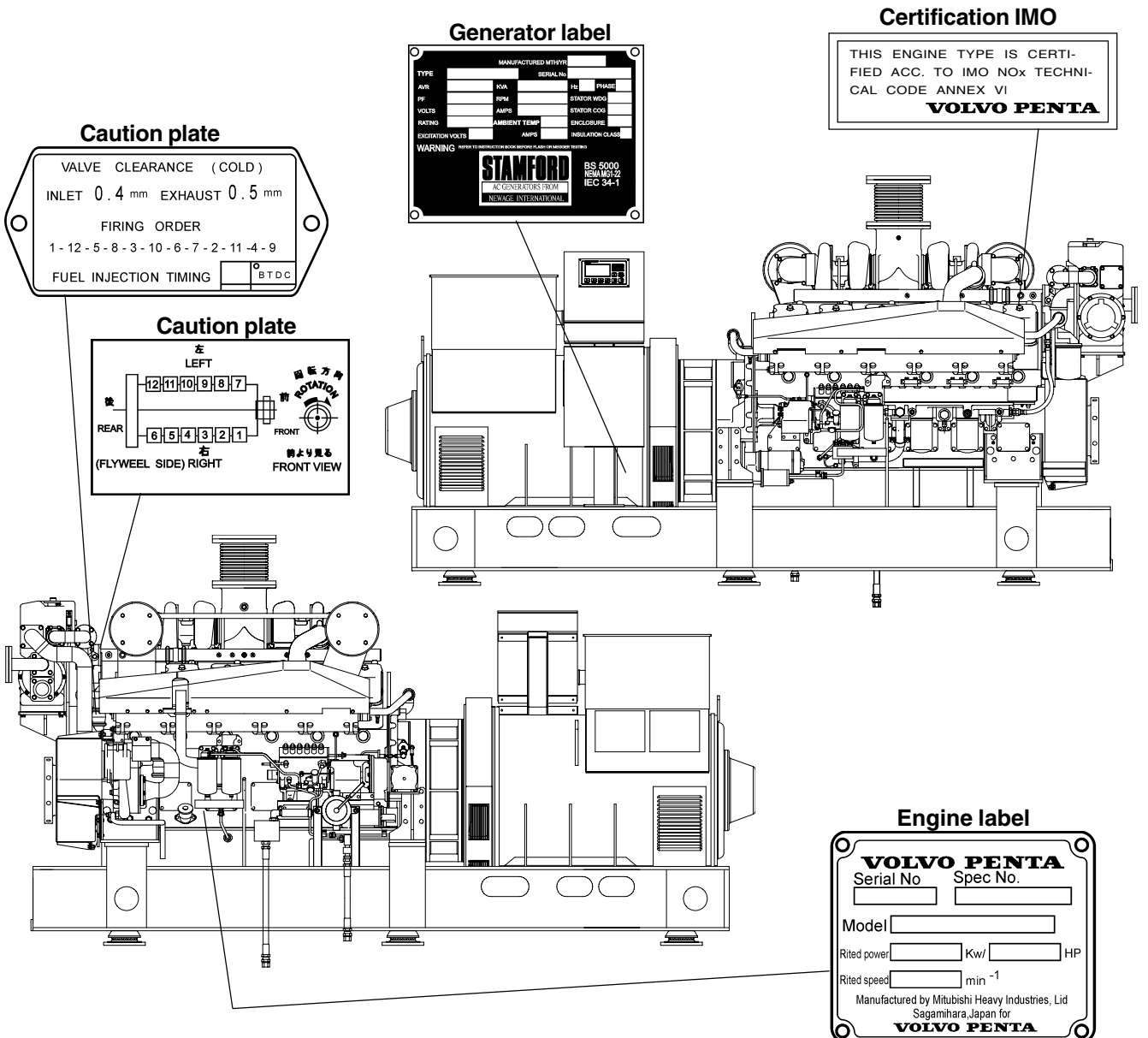

Notes



A series of horizontal dotted lines spaced evenly down the page, providing a template for handwritten notes.

A series of 20 horizontal dotted lines for writing.

Plus d'informations sur : www.dbmoteurs.fr