

OPERATOR'S MANUAL

D34A MS/MT

CALIFORNIA

Proposition 65 Warning

Diesel engine exhaust and some of its constituents are known to the State of California to cause cancer, birth defects, and other reproductive harm.

Plus d'informations sur : www.dbmoteurs.fr

Foreword

Thank you for purchasing this Volvo Penta diesel engine.

This manual contains operation instructions and maintenance and inspection information. In order to ensure safety and bring out the maximum performance of the engine, do not operate the engine until you have read and fully understood the contents of this manual. Do not hesitate to consult your Volvo Penta dealer.

Failure to follow the instructions and cautions in this manual may result in serious accidents.

* Keep this manual at hand for easy reference.

* If this manual is damaged or misplaced, immediately order a new copy from your dealer.

Contents

Foreword	3	Stopping	28
Safety Information	6	Manual Stop Lever	28
Safety regulations during engine operation	7	After stopping	29
Safety directions for maintenance and service	8	General	29
Warning labels D34A MS	10	Anti-freezing measures	29
Warning labels D34A MT	11	Breaks in operation [not using the engine]	29
Introduction	12	Maintenance	30
Care of the environment	12	Maintenance schedule D34A MS	31
Fuel and oil	12	Maintenance schedule D34A MT	34
Service and spare parts	12	Overhaul information	37
Certified engines	13	Recommendation of Daily Operation Records	39
Warranty	13	Engine	40
Presentation	14	Valve Clearance	40
D34A MS	14	Firing order	41
D34A MT	15	Turn the engine	42
New Engine Initial service	16	Vibration Damper Inspection	42
General	16	Re-tighten Bolts and Nuts	42
External Inspection	16	Fuel system	43
Valves and Plugs	16	Fuel system bleeding	43
Electrical Wiring	16	Fuel filter change	45
Fill Fuel system	16	Fuel injector nozzle change	46
Fill Lubrication system	16	Fuel injection pressure	47
Fill Cooling system	16	Injection timing inspection	49
Starting	17	Check fuel control	50
Before starting	17	Twin fuel pre-filter/water separator	51
Warming-up	17	Lubrication system	53
Standard control system	18	Lubrication oil level check	53
Instrument panels	18	Lubrication oil filling	53
Warning displays	19	Lubrication oil change	54
After an alarm	19	Oil filter change	55
Alarm test	19	Clean centrifugal by-pass oil filter	56
Starting switch	19	Hydraulic governor oil filter change	56
Starting procedure	20	Check the oil	56
Operation	21	Freshwater system	57
Alarms and fault indication	22	Coolant level check	57
Stopping the engine	22	Coolant filling	58
Emergency stop	22	Coolant drain	59
Operation	23	Freshwater system flushing	59
General	23	Seawater system	60
Applying Load	24	Draining the seawater system	60
Running in	24	Check and Change the zinc anodes	60
Forced propeller rotation	24	Seawater filter check/change	60
Manoeuvring	24	Seawater pump impeller check/change	61
Manual speed control	25	Heat exchanger cleaning	61
Start using auxiliary batteries	27		

Air Inlet and Exhaust Systems	62
Turbocharger Inspection	62
Cleaning the Air Cooler	62
Check air cooler drain pipe	62
Wash the air filter	63
Electrical system	64
Protective Devices Inspection	64
Check the electrical wiring	64
Starter motor inspection	64
Alternator Inspection	64
Drive belts. Check/Adjust/Change	64
Inhibiting	65
General	65
Preparation	65
Care during Storage	65
Return the Engine to Service	65
Storage of Engine in Operating Condition	66
Troubleshooting	67
Technical Data	68
D34A MS	68
D34A MT	69
Fuel specification	70
Lubrication oil specification	71
Coolant	72
Identification numbers D34A	79
Sea trial data	80

Safety Information

Read this chapter thoroughly. It concerns your safety. This section describes how safety information is presented in this manual and on the product. It also includes a summary of basic safety regulations for operation and maintenance of the engine.

Make sure you are in possession of the right operator's manual before reading on. If this is not the case, please get in touch with your Volvo Penta dealer.

If operations are performed incorrectly it could result in personal injury or damage to property or the engine. Read the Operator's Manual carefully before operating or servicing the engine. If anything is unclear please contact your Volvo Penta dealer for assistance.



 This symbol is used in the book and on the engine to make you aware of safety information. Always read these safety precautions very carefully.

In the Operator's Manual warning texts have the following priority:

 **WARNING!** If these instructions are not followed there is a danger of personal injury, extensive damage to the product or serious mechanical malfunction.

 **IMPORTANT!** Used to draw your attention to something that can cause damage, product malfunction or damage to property.

NOTE! Used to draw your attention to important information that will facilitate work or operations.

 This symbol is used in certain cases on our products and refers to important information in the Operator's Manual. Ensure that warning and information symbols on the engine and transmission are always visible and legible. Replace symbols that have been damaged or painted over.

Safety regulations during engine operation

The new engine

Read instruction manuals and other information accompanying the new vessel thoroughly. Accustom yourself with handling the engine, controls and other equipment in a safe and correct manner.

Remember that when operating a vessel, you have a legal responsibility to be aware of and follow regulations concerning traffic and safety at sea. Inform yourself of the regulations applicable to your vessel and the waters you are in by getting in touch with the relevant authorities or marine safety organization.

Accidents and other incidents

Sea rescue statistics show that deficient maintenance of vessels and engines together with defective safety equipment often causes accidents and other incidents at sea.

Make sure your vessel and engine are maintained in accordance with directions in the instruction manuals and that the safety equipment on board is in good working order.

Daily inspection

Make a habit of visually inspecting the engine and engine room before starting and after stopping the engine. This will help you to quickly detect any fuel, coolant or oil leaks and any other abnormalities that have occurred or are about to occur.

Maneuvering

Avoid violent and rapid rudder movement and gear shifting. There is a risk of the passengers falling down or falling overboard. A rotating propeller can cause serious injury. Make sure there is nobody in the water before engaging forward/reverse. Never run close to bathers or in places where you have reason to believe there are people in the water.

Filling fuel

There is a risk of fire and explosion when filling fuel. Smoking is prohibited and the engine must be turned off. Never overfill the tank. Close the filler cap securely. Use only fuel recommended in the operators manual. The incorrect grade of fuel can disturb operation or cause breakdown. This can also lead to the control rod jamming on diesel engines, which will cause the engine to overspeed and risk damaging machinery and causing personal injury.

Combustible environment

Due to the risk of fire and/or explosion, do not start or continue to run the engine if there is a suspected leak or discharge of combustible media, e.g. fuel oil or LPG, in the engine surroundings.

Carbon monoxide poisoning

When a vessel is moving forward, it will cause a certain vacuum to form behind the vessel. In unfortunate circumstances, the suction from this vacuum can be so great that the exhaust gases from the vessel are drawn into the bridge or cabin and cause carbon monoxide poisoning. This problem is most prevalent on high, wide vessels with abrupt stern. Other factors that can increase the effect of the suction are wind conditions, load distribution, swells, trim, open hatches and portholes, etc. Most modern vessels, however, are designed in such a way that this problem is very rare. If suction should arise anyway, do not open hatches or portholes at the fore of the vessel. Surprisingly, this will otherwise increase the suction. Try changing speed, trim, or load distribution instead. Get in touch with your Volvo Penta dealer for help in obtaining the best solution for your vessel.

Safety directions for maintenance and service

⚠ Preparations

Knowledge

The operator's manual contains directions for performing normal maintenance and service in a safe and correct manner. Read the directions carefully before starting work. More detailed service literature is available from your Volvo Penta dealer. Never perform a task unless you are absolutely sure how it is to be carried out; call your Volvo Penta dealer for assistance instead.

Stop the engine

Stop the engine before opening or dismantling the engine hatch/hood. Maintenance and service must be carried out with the engine stationary unless stated otherwise in the instructions. Prevent inadvertent start of the engine by removing the starter key and turning off the power with the main switch, locking it in the off position. Place warning signs stating that service is in progress in every position from which the engine can be started. Working on or approaching a running engine is a safety hazard. Loose clothing, hair, fingers or a dropped tool can be caught in rotating parts and cause serious bodily injury. Volvo Penta recommend leaving all work requiring the engine to be running to an authorized Volvo Penta dealer.

Lifting the engine

Always use the lifting eyes mounted on the engine when lifting the engine. Always make sure lifting equipment is in good condition and constructed for the lift (engine weight together with possible reverse gear and extra equipment). Use an adjustable lifting boom to ensure safe handling when lifting the engine. All chains and wires must run parallel with each other and as much at right angle as possible to the top of the engine. Note that any extra equipment mounted on the engine can change the center of gravity. Special lifting devices may be required to obtain the right balance and safe handling. Never perform service on an engine suspended only from a lifting device.

⚠ IMPORTANT! Engine must only be lifted horizontally.

⚠ IMPORTANT! Engine lifting eyes are designed only for lifting an engine. Do not use the engine lifting eyes when lifting a complete genset or an engine with a gearbox mounted.

Before starting

Refit all guards and covers that have been removed before starting the engine. Make sure there are no tools or other objects left on the engine. A turbocharged engine must never be started without the air filter fitted. The rotating compressor wheel in the turbocharger can cause severe personal injury.

There is also a risk of foreign objects being drawn in and causing mechanical damage.

⚠ Fire and explosion

Fuel and lubricants

All fuels, most lubricants, and many chemicals are flammable substances. Always read and follow the directions on the packaging. Work performed on the fuel system must be done on a cold engine. Fuel leaks and spills on hot surfaces or electrical components can cause fires.

Keep oil- and fuel drenched rags and other hazardous materials where they are safe in case of fire. Oil drenched rags can selfignite in certain conditions. Never smoke when refueling, topping up with oil or when in the vicinity of the fuel station or the engine room.

Non-original parts

Components in fuel, lubrication, ignition and electrical systems on Volvo Penta engines are designed and manufactured to minimize the risk of explosion and fire in compliance with existing legislation.

The use of non-original parts can result in explosion or fire.

Batteries

Batteries contain and generate oxyhydrogen gas, especially when charging. Oxyhydrogen is easily ignited and extremely explosive. Smoking, open flames and sparks must never occur in, or close to, the batteries or battery compartment. A faulty battery connection or jumper cable can generate sparks that can cause the battery to explode.

Start spray

Never use start spray or similar start help. Explosions can occur in the intake manifold. Risk for personal injury.

⚠ Hot surfaces and fluids

At operating temperature, the engine and its components are hot. A hot engine always involves risk for burn injuries. Take care with hot surfaces. E.g.: exhaust manifold, turbocharger, oil pan, charge air pipe, starting heater, hot coolant and warm lubricant in pipes and hoses.

⚠ WARNING! Do not open the crankcase covers while the engine is still hot.

⚠ Carbon monoxide poisoning

Start the engine in well-ventilated spaces only. When running in confined spaces, the exhaust gases and crankcase gases must be evacuated.

⚠ Chemicals

Most chemicals such as glycol, anti-corrosion agent, preservatives, degreasing agent, etc., are hazardous to health. Always read and follow the directions on the packaging.

Certain chemicals such as preservatives are flammable and harmful to inhale. Provide good ventilation and use breathing protection when spraying. Always read and follow the directions on the packaging. Store chemicals and other hazardous materials out of reach of children. Leave left over or used chemicals to a destruction plant.

⚠ Cooling system

There is a risk of water entering when working on the seawater system. Therefore, stop the engine and close the seawater cock before starting work.

Avoid opening the coolant filler cap when the engine is warm. Steam or hot coolant may spurt out and cause burn injuries.

If the filler cap, coolant pipe, cock, etc., must nevertheless be opened or dismantled while the engine is warm, the filler cap must be opened carefully to release the pressure before removing it completely and starting work. Note that the coolant can still be hot and cause burn injuries.

⚠ Lubricating system

Hot oil can cause burn injuries. Avoid skin contact with warm oil. Make sure the lubricating system is depressurized before starting work. Never start or run the engine with the oil filler cap removed or there will be a risk of the oil being thrown out.

⚠ Fuel system

Always protect your hands when carrying out leak detection.

Escaping fluids under pressure can pierce bodily tissue and cause serious injury. Risk of blood poisoning.

Always cover any electric component if it is located under the fuel filter. Otherwise it might be damaged by fuel spills.

⚠ Electrical system

Turn off the power before commencing work on the electrical system, the engine must be stopped and the powered turned off with the main switch/switches. Shore power to the engine heater, battery charger or other extra equipment fitted to the engine must be disconnected.

Batteries

Batteries contain a highly corrosive electrolyte. Protect your eyes, skin and clothing when charging and handling batteries. Always use protective goggles and gloves.

In case of splashes on the skin, wash with soap and plenty of water. In case of splashes in the eyes, rinse immediately with plenty of water and call a doctor.

Avoid burns and crushing or cutting!

At operating temperature, the engine coolant is hot and under pressure. Steam can cause personal injury. Check the coolant level only after the engine has been stopped and the coolant filler cap has cooled enough to touch with your hand. Never adjust the V-belts while the engine is running.

Service batteries carefully!

If you spill electrolyte on yourself, flush skin immediately with lots of water. Apply baking soda to help neutralize the acid. If electrolyte gets in your eyes, rinse immediately with large amounts of water then contact a doctor at once.

Handle antifreeze carefully!

Antifreeze contains alkali. Avoid contact with skin and eyes to prevent personal injury. Dispose of drained antifreeze coolant according to local regulations. For disposal, consult your dealer.

Dress properly for the job!

Wear protective devices - hard hat, face shield, safety shoes, goggles, heavy gloves, ear protectors, etc. - for your own safety.

Recommended fuel, lubrication oil and coolant!

Use of any other fuel oil, lubrication oil or coolant than the recommended can cause engine damage and reduce engine service life.

Perform all recommended inspections!

Perform pre-start inspection and periodic inspection on items listed in this manual. Failure to follow this recommendation can cause serious engine damage.

Warning labels D34A MS

The engine carries 'Warning Labels' at places where you are required to pay special attention. Please read them carefully and make sure you understand the content of each label and the meaning of their position.

1. Make sure the labels are legible. If you find any letter or picture illegible in a label, remove soil from the label, or replace it.
2. Clean the label with cloth and water or cleanser. Do not use organic solvent or gasoline, this would dissolve the label's adhesive and cause the label to fall off.
3. If any label is damaged, lost or illegible, replace it. When replacing a label, make sure the new label is identical to the old one. For new labels, please contact your dealer.

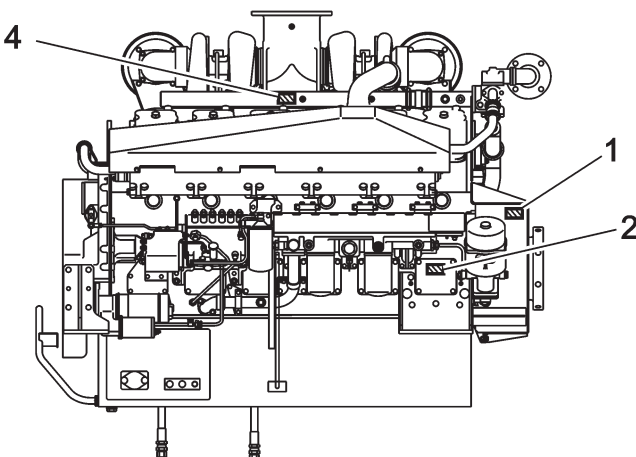
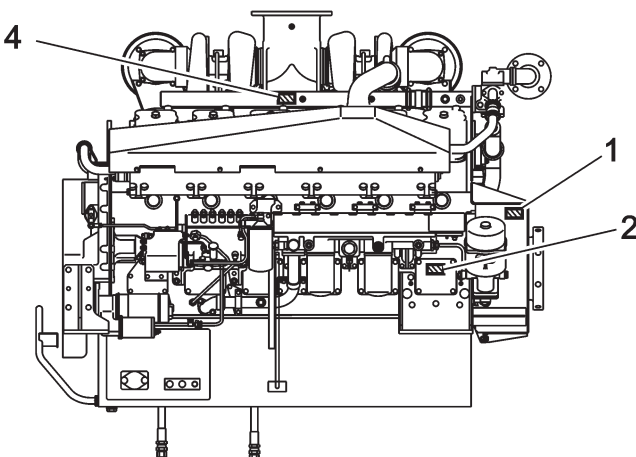
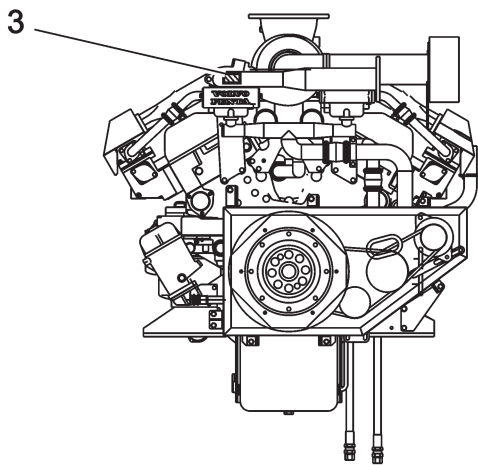
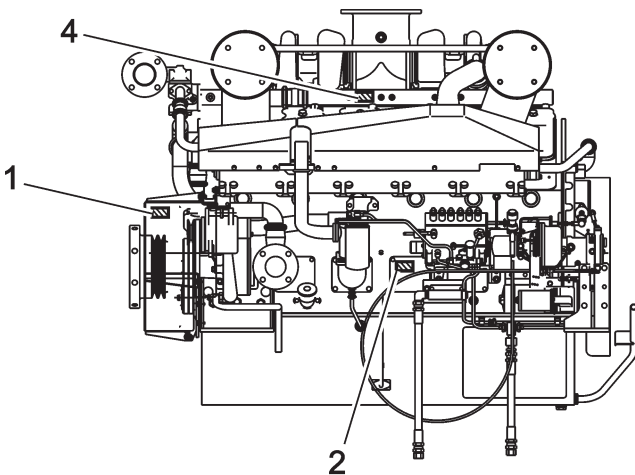

Warning labels D34A MT

The engine carries 'Warning Labels' at places where you are required to pay special attention. Please read them carefully and make sure you understand the content of each label and the meaning of their position.

1. Make sure the labels are legible. If you find any letter or picture illegible in a label, remove soil from the label, or replace it.
2. Clean the label with cloth and water or cleanser. Do not use organic solvent or gasoline, this would dissolve the label's adhesive and cause the label to fall off.
3. If any label is damaged, lost or illegible, replace it. When replacing a label, make sure the new label is identical to the old one. For new labels, please contact your dealer.

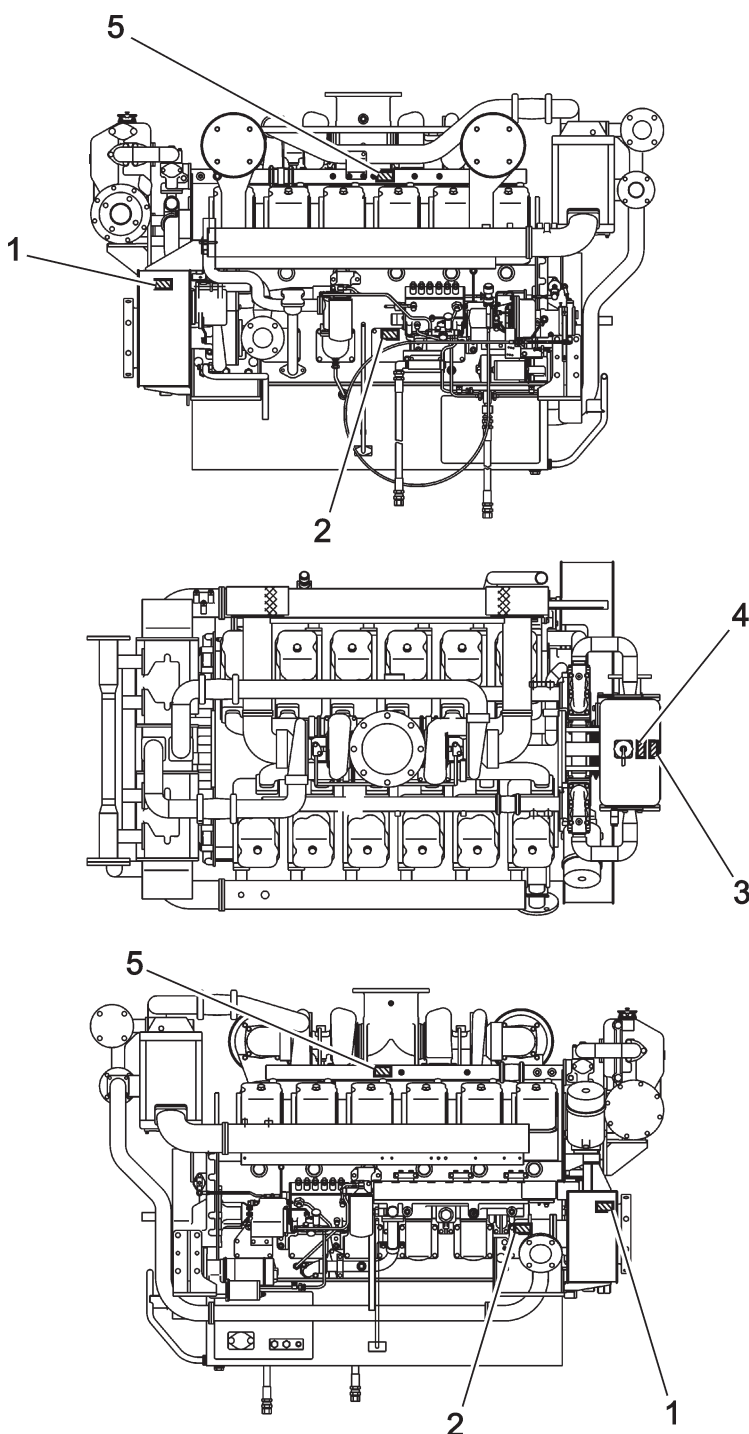

Introduction

This operator's manual has been produced to give you the greatest benefit of your Volvo Penta marine engine. It contains the information necessary to handle and maintain your engine in a safe and correct manner. We would like you to read this operator's manual thoroughly and learn how to handle the engine, controls and other equipment in a safe manner before starting to operate the engine.

Keep the operator's manual within reach at all times.

Care of the environment

We would all like to live in a clean and healthy environment. An environment where we can breathe clean air, see healthy trees, have clean water in our lakes and oceans, and are able to enjoy the sunshine without being worried about our health. Unfortunately, this cannot be taken for granted nowadays but is something we must work together to achieve.

As a manufacturer of marine engines, Volvo Penta has a special responsibility, why care of the environment is a core value in our product development. Today, Volvo Penta has a broad range of engines where progress has been made in reducing exhaust emissions, fuel consumption, engine noise, etc. We hope you will take care in preserving these qualities.

Always follow any advice given in the operator's manual concerning fuel grades, operation and maintenance and you will avoid causing unnecessary interference to the environment. Get in touch with your Volvo Penta dealer if you notice any changes such as increased fuel consumption exhaust smoke.

Adapt speed and distance to avoid wash and noise disturbing or injuring animal life, moored boats, jetties, etc. Leave islands and harbours in the same condition as you want to find them. Remember to always leave hazardous waste such as waste oil, coolant, paint and wash residue, flat batteries, etc., for disposal at a destruction plant. Our joint efforts will make a valuable contribution to our environment.

Fuel and oil

Use only fuel and lubrication oil grades recommended in the technical data section of this Operator's Manual. Other grades can cause operational problems, increase fuel consumption and have long-range effects on engine service life.

Service and spare parts

Volvo Penta marine engines are designed for high operational reliability and long service life. They are constructed to withstand the marine environment while affecting it as little as possible. Through regular service and the use of Volvo Penta original spare parts, these qualities will be retained.

The worldwide Volvo Penta network of authorized dealers is at your service. They are specialists in Volvo Penta products and stock accessories, original spare parts, test equipment and the special tools required to perform high-quality service and repairs.

Always follow the maintenance intervals specified in the operator's manual and remember to specify the engine number when ordering service and spare parts.

Certified engines

It is essential that owners and operators of emission certified engines, used in areas where exhaust emissions are regulated by law, are aware of the following points:

A certification involves the engine type being checked and approved by applicable authorities. Engine manufacturers guarantee that all engines of the same type correspond with the certified engine.

This puts special demands on the maintenance and service of your engine:

- * Maintenance and service intervals recommended by Volvo Penta must be followed.
- * Only Volvo Penta original spare parts may be used.
- * Service of injector pumps, pump settings and injectors must always be performed by an authorized Volvo Penta service person.
- * The engine must not be modified in any way with the exception of accessories and service kits approved by Volvo Penta for use on the engine.
- * Installation modifications must not be made to the engine exhaust pipe or inlet channels.
- * Sealed sections must not be broken by anyone other than authorized personnel.

Otherwise, general directions concerning running, care and maintenance given in the operator's manual apply.

⚠ IMPORTANT! Neglected or deficient maintenance/service and the use of non-original spare parts will entail Volvo Penta renouncing any responsibility for the engine corresponding to the certified version. Volvo Penta will not compensate for damage and/or costs arising from the above.

Warranty

Your new Volvo Penta marine engine is covered by a limited warranty complying with the conditions and instructions given in the Warranty and Service Book.

Note that AB Volvo Penta's responsibility is limited to what is specified in the Warranty and Service Book. Read it carefully as soon as possible after delivery. It contains important information concerning the warranty card, service, maintenance and what the owner is responsible to be aware of, check and perform. AB Volvo Penta will otherwise decline warranty liability completely or fully.

Get in touch with your Volvo Penta dealer if you have not received a Warranty and Service Book or a copy of the warranty card.

Presentation

D34A MS

The D34A MS is a direct injection, 12-cylinder, 4-stroke V-engine. It is equipped with two turbochargers and fitted with either a heat exchanger for thermostat-regulated freshwater cooling or connections for keel cooling.

An optimal combination of combustion chambers, fuel injection system, effective turbocharger and charge air cooling, provide excellent fuel consumption over the whole range of speeds where the engine is economical in operation.

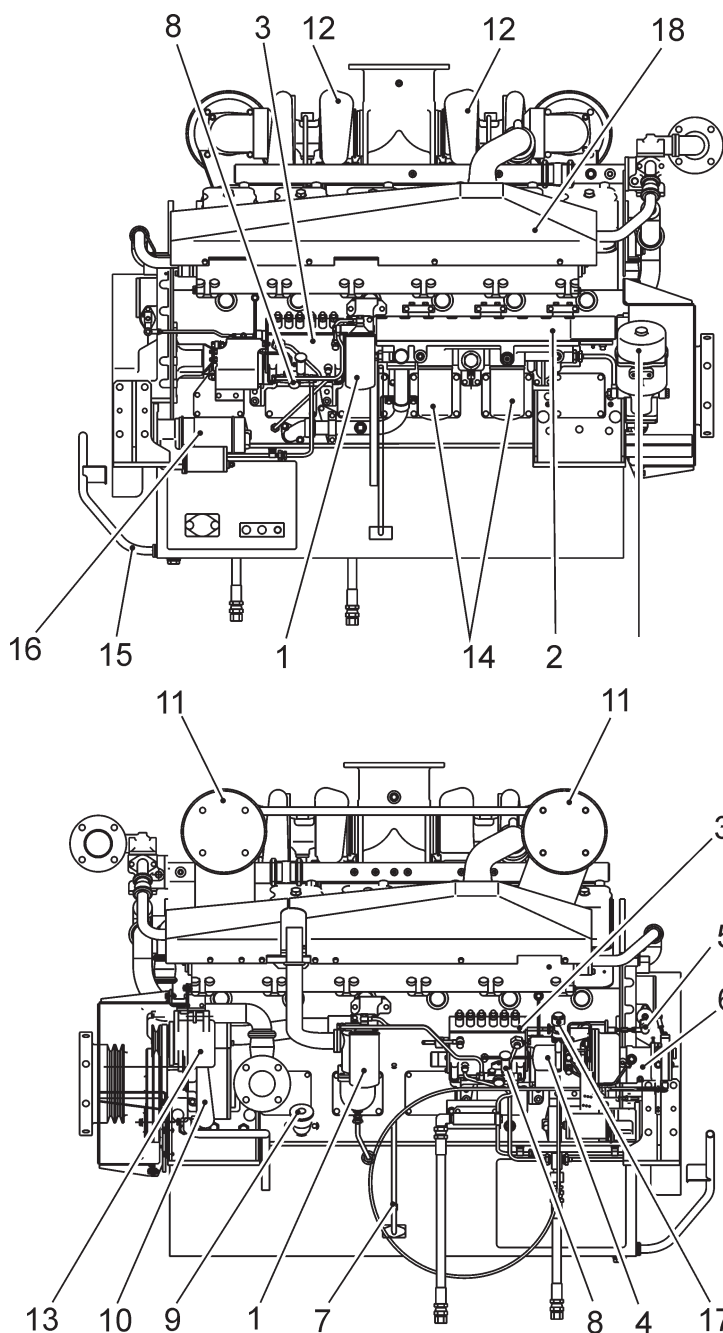

D34A MS

1. Fuel filters
2. Oil cooler
3. Fuel injection pump
4. Governor oil filter
5. Manual stop lever
6. Governor
7. Oil dipstick
8. Fuel feed pump
9. Oil filler cap
10. Fresh water pump
11. Intake air silencer
12. Turbocharger
13. Alternator
14. Oil filters
15. Engine oil drain pipe
16. Starter motor
17. Manual speed control knob
18. Charge air cooler

D34A MT

The D34A MT is a direct injection, 12-cylinder, 4-stroke V-engine. It is equipped with two turbochargers and fitted with either a heat exchanger for thermostat-regulated freshwater cooling or connections for keel cooling.

An optimal combination of combustion chambers, fuel injection system, effective turbocharger and charge air cooling, provide excellent fuel consumption over the whole range of speeds where the engine is economical in operation.

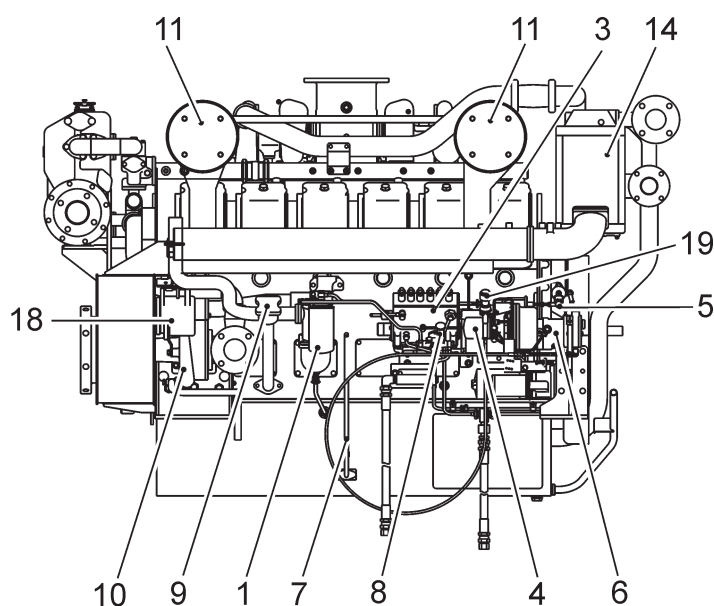

D34A MT

1. Fuel filters
2. Oil cooler
3. Fuel injection pump
4. Governor oil filter
5. Manual stop lever
6. Governor
7. Oil dipstick
8. Fuel feed pump
9. Oil filler cap
10. Fresh water pump
11. Intake air silencer
12. Turbocharger
13. Charge air cooler
14. Oil filters
15. Starter motor
16. Engine oil drain pipe
17. Sea water pump
18. Alternator
19. Manual speed control knob

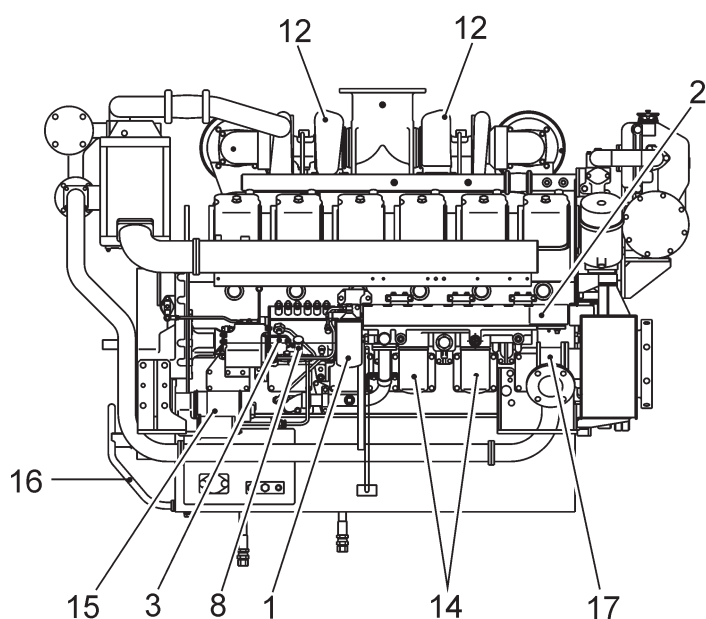

New Engine Initial service

General

Before starting a new or reconditioned engine for the first time, give it an initial inspection. This to guarantee your own safety as well as the maximum service life of the engine.

External Inspection

1. Check the engine control system for loose terminals.
2. Check defects of engine parts.
3. Check the following components for loose bolts or nuts:
 - * Plugs and covers of fuel, lubrication and cooling system
 - * Coupling of fuel injection pump and shaft
 - * Crankshaft pulley and vibration damper
 - * Mounting brackets
 - * Fuel control linkage
 - * Turbocharger
 - * Timing gear case
 - * Exhaust manifolds
 - * Cylinder heads
 - * Air-duct connection-hose clamp
4. Check for Fuel, Oil, Coolant and Air leaks and repair if needed.
5. Make commissioning report for new or overhauled engine.

 **IMPORTANT!** All covers must be mounted before attempting to start your engine.

Valves and Plugs

Make sure the following valves and plugs are open or closed properly:

Fuel supply valve	Open
Coolant drain cock (engine)	Closed
Coolant drain cock (water pump)	Closed
Coolant drain cock (heat exchanger)	Closed

 **IMPORTANT!** If the coolant drain cocks are not closed the coolant will drain from the engine and this may cause severe damage to the engine.

Electrical Wiring

Check for loose or damaged electrical wiring around the engine and if necessary firmly reconnect to terminals or cable-joint portions. Damaged cables must be replaced.

If your engine is reconditioned, make sure the wiring is according to the drawings.

Fill Fuel system

Refer to chapter maintenance fuel system.

Fill Lubrication system

Refer to chapter maintenance lubrication system.

Fill Cooling system

Refer to chapter maintenance cooling system.

Starting

Before starting

- ⚠ WARNING!** Before starting the engine make sure that neither people, nor tools, are in contact with moving parts of the engine. Notify the people in the vicinity of the engine when starting it.
- ⚠ WARNING!** Make sure that you know how to stop the engine before you start it (in case of emergency). If you are starting the engine for the first time, have someone stand-by at the emergency stop lever to stop the engine in case abnormal noise occurs during start up. Block air intake in case of stop lever malfunction, this has to be prepared in advance.
- ⚠ WARNING!** Make sure that the manual speed control knob is locked in neutral position before starting the engine (refer to page 26 of this manual).
- ⚠ IMPORTANT!** If the starter motor has been engaged for the maximum time (30 seconds), it must be allowed to cool down for at least one minute before a new attempt is made at starting.

Warming-up

- ⚠ WARNING!** Do not conduct warm-up operation for an extended period of time. Prolonged warm-up operation causes carbon buildup in the cylinders that leads to imperfect combustion.
- * Operate at low idle speed for 5 to 10 minutes to warm up the engine.
- * The oil pressure will be 0 after the warm-up run. If the engine speed is increased immediately after start-up, the oil pressure will exceed the normal level - (at rated speed) but it will normalize with increasing oil temperature.
- * If the Lubrication oil pressure does not increase when you have started the engine, immediately stop the engine and do not restart until the problem has been fixed.
- * Make sure that the cooling water flow is sufficient.

Standard control system

This chapter describes the standard Volvo Penta instruments that are available for your engine. Note that that tachometer, oil gauge, temperature gauge, charge gauge, starting switch, etc., that are shown here as panel mounted, in some cases may be mounted separately.

If the vessel is equipped with instruments not described here and you are not sure of their function, please get in touch with the shipyard or the company that installed the installation aboard the vessel.

⚠ IMPORTANT! Read the chapter “Starting” before starting your engine.

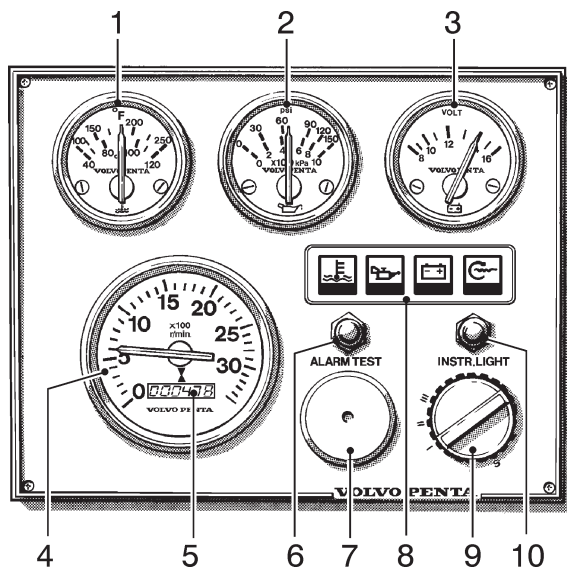

Instrument panels

Instrumentation for the main control position and auxiliary control position.

1. Temperature gauge. Indicates the engine coolant temperature.
2. Oil pressure gauge. Indicates the pressure of the engine lubricant.
3. Voltmeter. Indicates the charge voltage from the generator when the engine is running and the battery voltage when the engine is stopped.
4. Tachometer. Indicates the speed of the engine in rpm.
5. Hour counter. Shows the total number of engine running hours as a decimal number.
6. Press button for testing and acknowledging alarms (see next page “Warning displays”).
7. Siren for acoustic alarm that sounds if one of the warning lamps comes on.
8. Warning display (see section “Warning displays”, pos 1–3).
9. Starting switch (see next page).
10. Press button for instrument illumination.

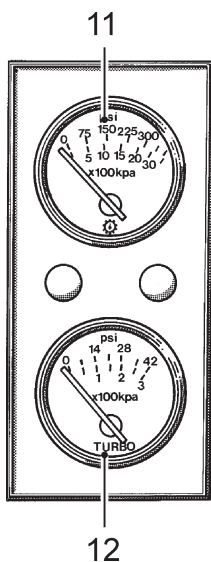

11. Oil pressure gauge. Indicates the oil pressure in the reverse gear.
12. Charge air pressure gauge. Indicates the turbo-charger boost pressure.

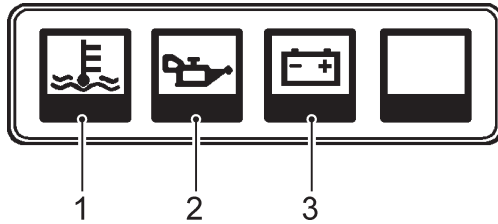

Warning displays

If the acoustic alarm sounds, one of the warning display lamps will immediately start to flash to indicate the cause of the alarm.

1. Coolant temperature too high.
2. Lubricant pressure too low.
3. Generator not charging



ALARM TEST

After an alarm

Press the "Alarm test" button to acknowledge and terminate the acoustic alarm. The relevant warning lamp will continue to flash until the fault has been rectified.

Alarm test

After pressing the "Alarm test" button, the warning lamps will come on and the acoustic alarm will start to sound. Make a habit of always performing an alarm test before starting.

Starting switch

Together with the starter keys a plate containing the key code is delivered. This code is required when ordering additional starter keys. Keep the code in a safe place.

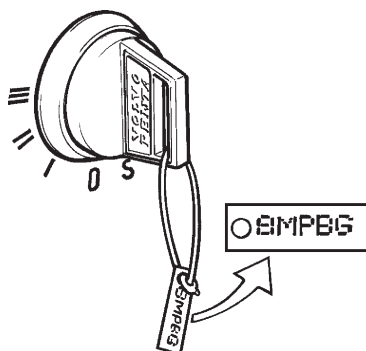

S = Stop position.

0 = Key can be inserted and removed.

I = Voltage on (drive position).

II = Not used

III = Start position.

Starting procedure

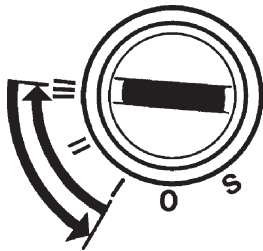
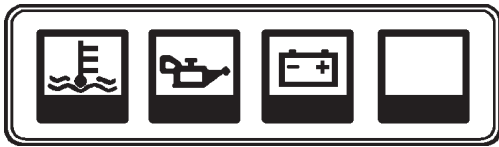
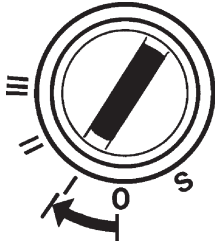

1. Disengage the reverse gear and make sure the turning gear is not engaged. Put the control lever into neutral and idle on all control positions

⚠ WARNING! If the vessel is equipped with controls that allow starting the engine in gear, it is essential to check all control positions to make sure a gear is not engaged.

2. Turn on the power by putting the starter key in position "I".

3. Check warning lamps and alarms. Press the "Alarm test" button on the instrument panel to make sure the warning lamps come on and the acoustic alarm sounds.

4. Start the engine. Start using the starting switch. Turn the key to position "III". Release the key so that it returns to "I" immediately after the engine has started.

⚠ IMPORTANT! If the starter motor has been engaged for the maximum time (30 seconds), it must be allowed to cool down for at least one minute before a new attempt is made at starting.

NOTE! The key must first be turned to "S" before making a new attempt at starting.

5. **Check the instruments and run the engine warm.** Let the engine idle for the first ten seconds and make sure the instruments and warning display show normal values. Then run the engine at low speed and low load so it attains normal operating temperature before using full power.

⚠ IMPORTANT! Do not race the engine when it is cold.

Operation

Learn how to handle the engine, controls and other equipment in a safe and correct manner before taking it into operation.

Check the instruments

Check the instruments and warning display directly after start and regularly during operation.

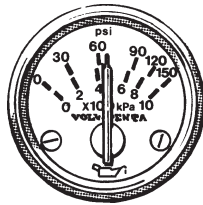

Oil pressure

During operation, the oil pressure gauge should show a reading of 0,50 - 0,64 MPa (71 - 93 psi). A lower value is normal at idling speed. The acoustic alarm will sound automatically in case of low oil pressure.

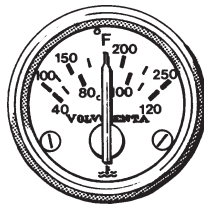

Coolant temperature

During operation, the temperature gauge should show a reading of 71–85°C (160–185°F). The acoustic alarm will sound automatically in case the coolant temperature is too high.

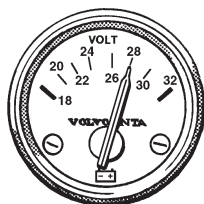

Charging

During operation, the charge voltage gauge should show a reading of 28V. The acoustic alarm will sound automatically in case the charge voltage is missing.

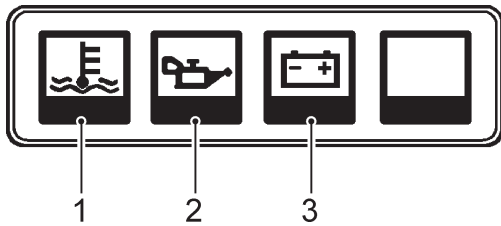

Alarms and fault indication

If the acoustic alarm sounds, one of the warning display lamps will immediately start to flash to indicate the cause of the alarm: High coolant temperature (1), low oil pressure (2) and no charge voltage (3).

⚠ IMPORTANT! Stop the engine immediately after an alarm for low oil pressure. Investigate the cause and rectify it.

⚠ IMPORTANT! Slow the engine speed to idle/disengaged after an alarm for high coolant temperature. If temperature does not drop, the engine must be stopped. Investigate the cause and rectify it.

Stopping the engine

Let the engine run at low idling speed (in neutral) for at least three minutes before turning it off. This will keep the engine temperature in balance and prevent it boiling.

⚠ IMPORTANT! The procedure described above is especially important if the engine has been run hard and/or exerted to heavy loads.

Stop

1. Disengage the marine gear by moving the lever to neutral position.
2. Turn the key to stop position "S".
3. Hold the key in position until the engine has stopped (the key will return to "0" automatically when released and can then be removed).

NOTE! The stop solenoid will be activated for approximately 40 seconds after stopping the engine, but the engine can be restarted at any time.

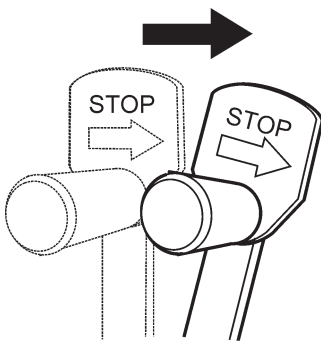

Emergency stop

If a fault occurs that prevents the engine being stopped by the normal method, it can be stopped manually using the lever mounted on the engine. Move the lever in the direction of the arrow and hold it there until the engine has stopped.

⚠ WARNING! Working on or approaching a running engine is a safety hazard. Beware of rotating parts and hot surfaces.

⚠ WARNING! Never try to increase engine rpm with the emergency stop lever since this will make the engine overspeed and this will damage the engine.

Operation

General

Learn how to handle the engine, controls and other equipment in a safe and correct manner before starting the engine

 **WARNING!** Stay clear of all rotating and moving parts during operation.

 **IMPORTANT!** Always keep the engine room well ventilated. Insufficient air supply to the engine means imperfect combustion and a loss of power.

 **IMPORTANT!** During the first 50 hours of operation, operate the engine under a lighter load and lower speeds than normal for break-in. Proper break-in contributes to maximum service life of the engine.

 **IMPORTANT!** Do not turn OFF the battery switch when the engine is running since this may damage the alternator.

 **WARNING!** At operating temperature, the engine and its components are hot. A hot engine always involves risk for burn injuries. Take care with hot surfaces. E.g.: exhaust manifold, turbocharger, oil pan, charge air pipe, starting heater, hot coolant and warm lubricant in pipes and hoses.

 **IMPORTANT!** Avoid overloading. This can cause incomplete fuel combustion often indicated by black exhaust, high fuel consumption and carbon deposits in combustion chambers, affecting engine life.

 **IMPORTANT!** Do not turn the starter switch key to the START position when the engine is running this may damage the starter.

Applying Load

When the engine has reached operation temperature, bring the engine to operating speed and apply the load gradually.

During load operation make sure that:

1. No engine related alarms occur.
2. There are no visible leaks of fuel, lube oil, coolant or exhaust gas
3. No abnormal noise or vibrations occur.
4. The color of the exhaust gas is normal.
5. The breather mist is of normal quantity and color.
6. Instrument readings are the normal.*
*Oil pressure: 0,49 to 0,64 Mpa (71 to 92 psi) (at rated speed)
*Coolant temperature: 71 to 85°C (165 to 185 °F)

Running in

The engine must be “run in” during the first 10 hours of operation as follows:

Run the engine under normal operation. Do not run it at full power except for short periods. Never run the engine for long periods at constant rpm during this time. A high consumption of lubricant is normal during the running in period. Therefore, check the oil level more often than recommended. The prescribed warranty inspection “First Service Inspection” must be carried out during this first period of operation. For more information: See Warranty and Service Book.

Forced propeller rotation

When the vessel is towed or anchoring in strong currents, the propeller can make the propeller shaft rotate even though the engine is stationary. This may damage the marine gear.

Manoeuvring

The marine gear must be engaged at low idling speed. There must be a brief pause after engaging gear before increasing the engine speed. Wait for approximately two seconds to ensure that the gear clutch has engaged properly.

 **IMPORTANT!** If the vessel is equipped with two engines equipped with wet exhaust systems, they must both be running while in reverse or there will be a risk of water entering the engine (through the exhaust passage).

Pulling away

1. Move the lever from neutral to the engagement position for the desired direction of travel.
2. Apply load accordingly.

Forward–Reverse

1. Slow the engine speed to idling and allow the vessel to lose most of its speed.
2. Move the lever to neutral.
3. Move the lever to reverse. Wait for approximately two seconds and then increase the engine speed gradually.

 **IMPORTANT!** A direct forward–reverse maneuver can damage the marine gear and engine. It is therefore always necessary to stop with the lever in neutral for a few seconds and allow the vessel to lose most of its speed before engaging. If the speed of the vessel is too high, there is a risk of the propeller windmilling which might cause the engine to stop and start rotating in the wrong direction. This may cause serious engine damage.

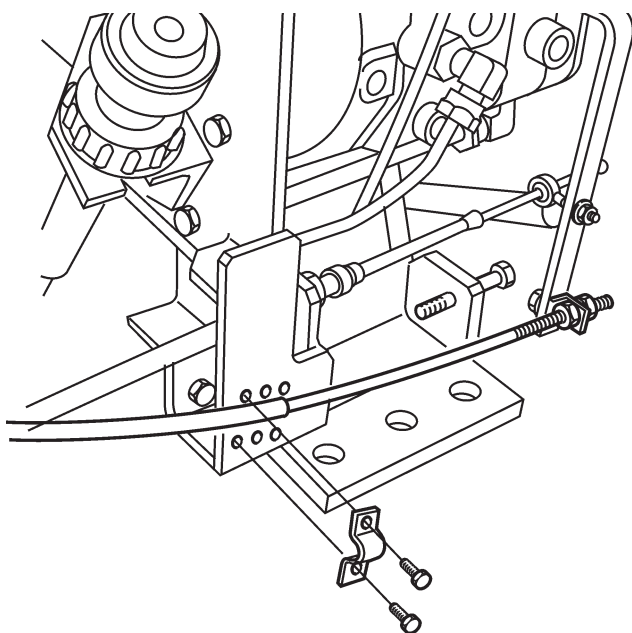

Manual speed control

Manual speed adjustment of the engine can be done using the manual speed control knob.

1. Disconnect the control cable connected to the remote speed adjustment.

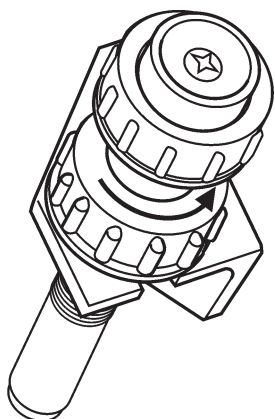

2. Turn the Lock counterclockwise to unlock the manual speed adjustment knob.

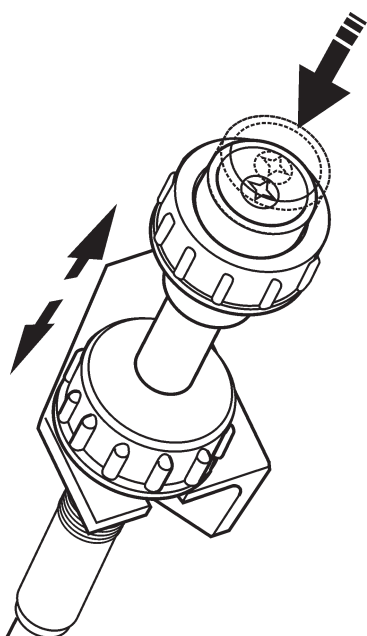

3. By pushing the button and pulling the knob towards you the engine speed will increase. By bushing the knob towards the engine the engine speed will decrease.

⚠ WARNING! When adjusting engine speed avoid quick changes since this may harm the engine.

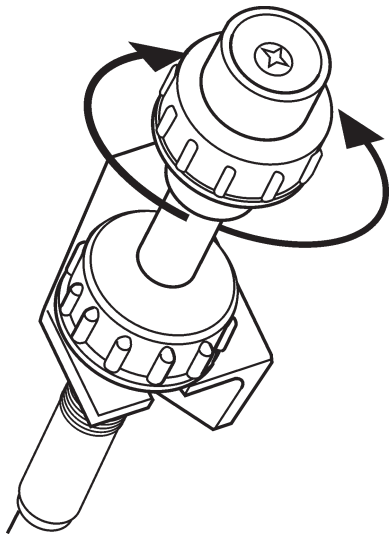

4. Fine-tuning of the engine speed can be done by turning the control knob:

Turn the knob clockwise to decrease engine speed. Turn it counterclockwise to increase engine speed.

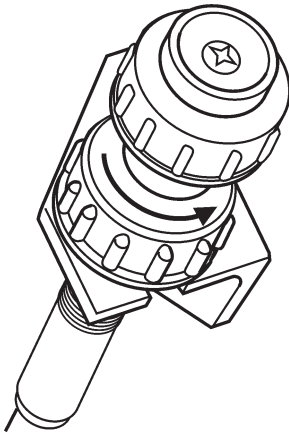

5. Bring the manual speed control knob in the neutral position when ready with the manual speed adjustment. Turn the lock clockwise to secure the installation.

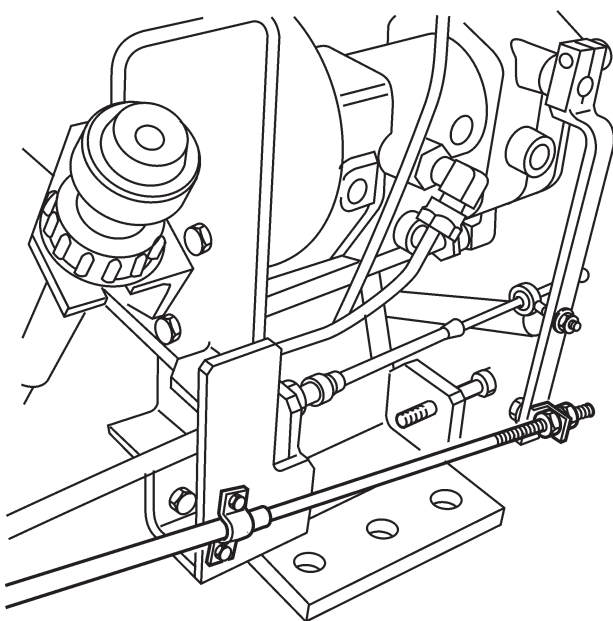

6. Connect the control cable for remote speed adjustment so that the engine can be controlled from the normal position.



Start using auxiliary batteries

⚠ WARNING! Ventilate well. Batteries generate oxyhydrogen gas, which is extremely flammable and explosive. A short circuit, naked flame or spark can cause a powerful explosion.

Never reverse the polarity of the battery. Risk of sparks and explosion.

1. Make sure the rated voltage of the auxiliary battery is the same as the system voltage of the engine.
2. Connect the red auxiliary cable to the discharged battery's + terminal and then to the auxiliary battery's + terminal.
3. Connect the black jump lead to the auxiliary battery negative terminal and then to a position slightly away from the discharged batteries, for example at the negative cable's connection to the starter motor.

⚠ WARNING! The black auxiliary cable (–) must not come in contact with the positive connection on the starter motor.

4. Start the engine and run at fast idling speed for about ten minutes to charge the batteries.

⚠ WARNING! Working on or approaching a running engine is a safety hazard. Beware of rotating parts and hot surfaces.

⚠ WARNING! Do not touch the connections while attempting to start; Risk of sparks. Do not bend over the batteries either.

5. Stop the engine. Remove the auxiliary cables in reverse order to connecting.

Stopping

Let the engine run at low idling speed (in neutral) for at least 5 to 6 minutes before turning it off. This will keep the engine temperature in balance and prevent it from boiling.

⚠ IMPORTANT! The procedure described above is especially important if the engine has been run hard and/or exerted to heavy loads.

⚠ IMPORTANT! Do not rev up the engine just before stopping it.

⚠ IMPORTANT! If the engine stops abnormally, try to locate the problem and make the repairs needed before starting again. After starting the engine, make sure the engine runs properly.

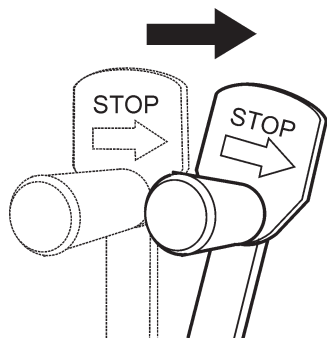

Manual Stop Lever

By pulling the manual stop lever in the “STOP” direction the engine can be stopped manually. Use this lever only in an emergency when the engine can not be stopped by the engine control system.

⚠ IMPORTANT! When stopping the engine by pulling the stop lever, continue to pull the lever until the engine stops “rocking.”

Notice: If the engine cannot be stopped with the manual stop lever, shut off the fuel supply or block air intake to turbo.

After stopping

General

* Check the engine and engine room for leaks.

* Close the fuel cock and seawater cock.

⚠ IMPORTANT! Do not forget to open the cocks before starting the engine again.

* Read off the hour counter and carry out preventive maintenance according to the maintenance schedule.

* Turn off the main switch if the engine is not to be used for a long period.

⚠ IMPORTANT! Never turn the power off using the main switch while the engine is running. This can damage the alternator.

Anti-freezing measures

If the engine room cannot be protected from frost, the sea-water system must be drained and the coolant in the fresh-water system must contain sufficient anti-freeze to prevent it from freezing. Refer to chapter Maintenance "Seawater system" and "Freshwater system" respectively.

⚠ WARNING! If the seawater system bursts due to freezing, it is possible for the vessel to sink.

⚠ IMPORTANT! If the coolant does not give sufficient anti-freeze protection, it may cause costly damage to the engine. Check the charge of the battery. A poorly charged battery can freeze and break.

Breaks in operation [not using the engine]

During periods out of service, when the boat is in the water, the engine must be run warm once a fortnight. This will prevent the engine from corroding.

⚠ IMPORTANT! The engine must be conserved if it is not to be used for longer than two months. Refer to chapter Inhibiting.

Maintenance

Your Volvo Penta engine and associated equipment is designed to provide high operational reliability and long service life. They are constructed to withstand the marine environment while also affecting it as little as possible.

Preventive maintenance in accordance with the maintenance schedule will ensure that it retains these qualities and avoid unnecessary operational disturbances.

The maintenance chart shows the standard service intervals. When you think the engine should be serviced more frequently due to particular operating conditions, adjust the intervals accordingly. Appropriate service intervals vary depending on the usage and operating conditions as well as the fuel, lubricant and coolant used. Due to particular operating conditions the service intervals may be adjusted accordingly. Consult your Volvo Penta dealer.

Daily operation records

It is recommended to keep daily operation records every day. Daily recording is a preventive maintenance program and when comparing values with engine history it will help you recognize conditions, signs or indications of approaching trouble. Daily operation records also make trouble shooting easier and will lessen the down time (to save time and money for servicing).

Maintenance records



Volvo Penta recommends that accurate maintenance records are kept. With accurate maintenance records your Volvo Penta Dealer can help in fine tuning the recommended service intervals to meet the specific operating situation. This should result in a lower engine operation cost.

Fluids

It is also important to keep record of the fluids used in the engine. If brand or type of fuel, lubrication oil or coolant is changed this should be recorded. For fluids used at sea trial refer to chapter Technical Data.

Warranty inspection

The prescribed warranty inspection "First Service Inspection" must be carried out at an authorized Volvo Penta workshop during this first period of operation. Directions for when and where this is to be carried out can be found in the **Warranty and Service Book**.

-  **WARNING!** Read the chapter "Maintenance" thoroughly before starting any maintenance work. It contains directions for performing maintenance in a safe and correct manner.
-  **WARNING!** Working on or approaching a running engine is a safety hazard. Maintenance and service must be carried out with the engine stationary unless stated otherwise in the instructions. Prevent inadvertent start of the engine by removing the starter key and turning off the power with the main switch, locking it in the off position.
-  **WARNING!** Place warning signs stating that service is in progress in every position from which the engine can be started.

MAINTENANCE SCHEDULE D34A MS

Daily before first start

* General inspection engine and engine room	not illustrated
* Check and make sure all valves are in the right position	page 18
* Check lubrication oil level	page 50
* Check marine gear oil level	not illustrated
* Check lubrication oil filter differential pressure indicator	not illustrated
* Check air-filter differential pressure indicator	not illustrated
* Check coolant level	page 55
* Check fuel oil level	not illustrated
* Drain water from fuel tank	page 43
* Drain water from fuel pre-filter/water separator	page 48
* Drain water from air vessel and air filter	not illustrated
* Check engine control system (cables, etc.)	not illustrated
* Check fuel control linkage	page 47
* Check for leakages	not illustrated
* Check aftercooler drain pipe	not illustrated
* Daily operation records	page 7
* Inspection of valves and plugs	not illustrated
* Check if the instrumentation works properly	not illustrated

Weekly

* Check starting batteries; electrolyte level/load	not illustrated
* Check electrical system for loose terminals/contacts	page 62
* Check foundation bolts	not illustrated
* Check lubrication oil for abnormal smell or waterdilution	not illustrated
* Check safety valves of air system	not illustrated
* Check air system oiler	not illustrated
* Check settings of valves and move valve to keep them operationable	not illustrated
* Drain water from the fuel pre-filter/water separator	page 48
* Drain crankcase ventilation water trap	not illustrated
* Drain exhaust silencer(system) water trap	not illustrated

First 50-250 operating hours of new or recond. engines (First service)

* Change lubrication oil	page 52
* Change full flow and by-pass lubrication oil filters	page 53 - 54
* Change governor lubrication oil filter	page 54
* Check required lubrication oil change for marine gear	not illustrated
* Check/adjust V-belts	page 62
* Check/adjust valve clearance	page 36 - 37
* Check/adjust stop solenoid and/or fuel stop valve	not illustrated
* Check/retighten bolts and nuts	page 38

Every 250 operating hours or every 12 months

- * Change lubrication oil. Longer interval requires oil analysis page 52
- * Change full flow and by-pass lubrication oil filters page 53 - 54
- * Check/adjust V-belts page 62
- * Check sea water filter page 59
- * Check/wash air pre-cleaner (turbo) page 61

Every 500 operating hours or every 12 months

- * Change governor lubrication oil filter page 56
- * Clean centrifugal by-pass lubrication oil filter⁽¹⁾ page 56

Every 1000 operating hours or every 12 months

- * Change fuel filter elements page 42
- * Change filter elements of the fuel pre-filter/water separator page 48 - 49
- * Check air filter (if installed) not illustrated
- * Check/retighten bolts and nuts page 38
- * Check/adjust fuel injection timing. page 46
- * Check/adjust fuel injection pressure and spray pattern page 44 - 45
- * Change fuel injection nozzle o-rings. not illustrated
- * Check and adjust valve clearance and valve mechanism. page 36 - 37

Every 2000 operating hours or every 12 months

- * Check/adjust valve clearance. Check valvemechanism pages 36/37
- * Check turbocharger. page 61
- * Check starter motor page 62
- * Check alternator page 62
- * Check fuel injection pump flex drive plates not illustrated
- * Check fuel injection pump control rack operation page 47
- * Check fuel rack control "ball joints" page 47
- * Check/clean charge air cooler(s) page 61
- * Check/clean cooling water heat exchanger page 60
- * Check coolant concentration not illustrated
- * Check torsional vibration dampers page 38
- * Check alarm and shut-down functions not illustrated
- * Check engine control panel functions (see chapter control system)
- * Change V-belts not illustrated
- * Change fuel pre-filter/water separator element pages 48/49
- * Check/change zinc anodes page 58
- * Change turbo charger air filter page 61

Every 4000 to 6000 operating hours or every 24 months

* Full service inspection⁽²⁾ consult Volvo Penta dealer

Every 12 months

* Check rubber engine mounts not illustrated

* Check rubber hoses and flex connections not illustrated

* Check engine room ventilation fans not illustrated

Every 10000 operating hours

* Check torsional vibration damper temp check not illustrated

* Check rubber of flexible coupling for deformation and cracks not illustrated

* Replace ball-joints in fuel pump control linkage not illustrated

* Check all safety switches, instruments and senders not illustrated

Every 15000 operating hours

* Full service inspection⁽³⁾ consult Volvo Penta dealer

Every 24 months

* Change coolant not illustrated

(1) In case by-pass filter is very dirty, shorten check interval to 250 hrs.

(2) Every 4000 to 6000 hours or every 24 months

Have an authorized dealer execute a full service inspection of your engine including:

Endoscopic investigation of cyl heads and liners

Replace all injector nozzles

Change water pump seals

Checking and cleaning of charge air cooler

Check turbo charger

Check battery-charging alternator

Check and test stop solenoid and fuel shut-off valve

(3) Every 15000 hours

Have an authorized dealer execute a full service inspection of your engine including:

As described at 4000 – 6000 hrs

Remove and inspect one piston, piston rings and liner

Inspect crankshaft and one bearing

MAINTENANCE SCHEDULE D34A MT

Daily before first start

- * General inspection engine and engine room not illustrated
- * Check and make sure all valves are in the right position page 18
- * Check lubrication oil level page 50
- * Check marine gear oil level not illustrated
- * Check lubrication oil filter differential pressure indicator not illustrated
- * Check air-filter differential pressure indicator not illustrated
- * Check coolant level page 55
- * Check fuel oil level not illustrated
- * Drain water from fuel tank page 43
- * Drain water from fuel pre-filter/water separator page 48
- * Drain water from air vessel and air filter not illustrated
- * Check engine control system (cables, etc.) not illustrated
- * Check fuel control linkage page 47
- * Check for leakages not illustrated
- * Check aftercooler drain pipe not illustrated
- * Daily operation records page 7
- * Inspection of valves and plugs not illustrated
- * Check if the instrumentation works properly not illustrated

Weekly

- * Check starting batteries; electrolyte level/load not illustrated
- * Check electrical system for loose terminals/contacts page 62
- * Check foundation bolts not illustrated
- * Check lubrication oil for abnormal smell or waterdilution not illustrated
- * Check safety valves of air system not illustrated
- * Check air system oiler not illustrated
- * Check settings of valves and move valve to keep them operationable not illustrated
- * Drain water from the fuel pre-filter/water separator page 48
- * Drain crankcase ventilation water trap not illustrated
- * Drain exhaust silencer(system) water trap not illustrated

First 50-250 operating hours of new or recond. engines (First service)

- * Change lubrication oil page 52
- * Change full flow and by-pass lubrication oil filters page 53 - 54
- * Change governor lubrication oil filter page 54
- * Check required lubrication oil change for marine gear not illustrated
- * Check/adjust V-belts page 62
- * Check/adjust valve clearance page 36 - 37
- * Check/adjust stop solenoid and/or fuel stop valve not illustrated
- * Check/retighten bolts and nuts page 38

Every 250 operating hours or every 12 months

- * Change lubrication oil. Longer interval requires oil analysis page 52
- * Change full flow and by-pass lubrication oil filters page 53 - 54
- * Check/adjust V-belts page 62
- * Check sea water filter page 59
- * Check/wash air pre-cleaner (turbo) page 61

Every 500 operating hours or every 12 months

- * Change governor lubrication oil filter page 54
- * Clean centrifugal by-pass lubrication oil filter not illustrated

Every 1000 operating hours or every 12 months

- * Change fuel filter elements page 42
- * Change filter elements of the fuel pre-filter/water separator page 48 - 49
- * Check air filter (if installed) not illustrated
- * Check/retighten bolts and nuts page 38
- * Check/adjust fuel injection timing. page 46
- * Check/adjust fuel injection pressure and spray pattern page 44 - 45
- * Change fuel injection nozzle o-rings. not illustrated
- * Check and adjust valve clearance and valve mechanism. page 36 - 37
- * Check sea water pump not illustrated

Every 2000 operating hours or every 12 months

- * Check/adjust valve clearance. Check valvemechanism pages 36/37
- * Check turbocharger. page 61
- * Check starter motor page 62
- * Check alternator page 62
- * Check fuel injection pump flex drive plates not illustrated
- * Check fuel injection pump control rack operation page 47
- * Check fuel rack control "ball joints" page 47
- * Check/clean charge air cooler(s) page 61
- * Check/clean cooling water heat exchanger page 60
- * Check coolant concentration not illustrated
- * Check torsional vibration dampers page 38
- * Check alarm and shut-down functions not illustrated
- * Check engine control panel functions (see chapter control system)
- * Change V-belts not illustrated
- * Change fuel pre-filter/water separator element pages 48/49
- * Check/change zinc anodes page 58
- * Change turbo charger air filter page 61

Every 4000 to 6000 operating hours or every 24 months

* Full service inspection⁽¹⁾ consult Volvo Penta dealer

Every 12 months

* Check rubber engine mounts not illustrated

* Check rubber hoses and flex connections not illustrated

* Check engine room ventilation fans not illustrated

Every 10000 operating hours

* Check torsional vibration damper temp check not illustrated

* Check rubber of flexible coupling for deformation and cracks not illustrated

* Replace ball-joints in fuel pump control linkage not illustrated

* Check all instruments, senders and switches not illustrated

Every 15000 operating hours

* Full service inspection⁽²⁾ consult Volvo Penta dealer

Every 24 months

* Change coolant not illustrated

(1) Every 4000 to 6000 hours or every 24 months

Have an authorized dealer execute a full service inspection of your engine including:

Endoscopic investigation of cyl heads and liners

Replace all injector nozzles

Change water pump seals

Checking and cleaning of charge air cooler

Check turbo charger

Check battery-charging alternator

Check and test stop solenoid or fuel shut-off valve

(2) Every 15000 hours

Have an authorized dealer execute a full service inspection of your engine including:

As described at 4000 – 6000 hrs

Remove and inspect one piston, piston rings and liner

Inspect crankshaft and one bearing

Inspect camshaft and one bearing

Overhaul information

Top overhaul

Dependent of your application, working conditions and service level a “top overhaul” might be required in case of:

Gas leakage through valves

Too much valve clearance

Low compression pressure

Top overhaul includes:

Remove cylinder heads and check liners and combustion chambers of pistons

Disassemble cylinder heads

Check inlet and exhaust valves, check valve seats (lap if necessary)

Check piston top

Check cylinder liner

Check instruments, alarms and shutdown functions

Check pipe clamp contact

Change fresh water pump seals

Change sea water pump seals

Overhaul turbo charger

Check vibration damper on burrs and leaks

Check exhaust pipe joints

Check governor control linkage

1st major overhaul

Dependent of your application, working conditions and service level a “major overhaul” might be required in case of:

Decreased power output

Increased fuel consumption

Increased lubrication oil consumption

Increased blow-by gases

Gas leakage through valves

Starting problems

Increased noise from engine parts

Abnormal color of exhaust gases from warm engine

Major overhaul includes:

Disassemble engine, clean, check and change major parts.

Major parts:

Inlet and exhaust valve seats

Inlet and exhaust valves

Valve rotators

Valve cotters

Rocker arm adjusting screws

Valve push rods

Bridge caps

Camshaft bushings

Camshaft expansion plugs

Lubrication oil pump

Main bearings

Cylinder liners

Main bearing cap bolts and washers

Piston rings

Connecting rod bearings

Vibration damper

Air duct rubber hoses

Cooling water rubber hoses

Consumable items (gaskets, oil seals, o-rings, etc.)

Change the torsional vibration damper

2nd major overhaul

Disassemble engine, clean, check and change major parts.

Major parts:

Inlet and exhaust valve seats	Cylinder liners
Inlet and exhaust valves	Main bearing cap bolts and washers
Valve rotators	Piston rings
Valve cotters	Connecting rod bearings
Rocker arm adjusting screws	Vibration damper
Valve push rods	Air duct rubber hoses
Bridge caps	Cooling water rubber hoses
Camshaft bushings	Consumable items (gaskets, oil seals, o-rings, etc.)
Camshaft expansion plugs	Rocker bushings
Cylinder head bolts	Thrust plate crankshaft
Valve guides	Pistons and piston pins
Valve bridge guides	Connecting rod bolts
Valve bridges	Connecting rod bushings etc.
Valve springs	Check high-pressure fuel injection pump and fuel supply pump
Tappets	Change torsional vibration damper
Camshaft thrust plates	
Main bearings	

Recommendation of Daily Operation Records

Daily recording is a preventive maintenance program and when comparing values with engine history it will help you recognize conditions, signs or indications of approaching trouble. Daily operation records also make trouble shooting easier and will lessen the down time (to save time and money for servicing).

Items to be recorded

The following items are recommended to be recorded once a day:

1. Operating hours.
2. The amount of lubrication oil and coolant (fresh water) required for refilling. Fuel consumption.
3. Lubrication oil and coolant (fresh water) change intervals.
4. Lubrication oil pressure and temperature, engine rpm, exhaust temperature, coolant temperature, and charge air temperature and pressure.
5. Seawater pressure and seawater temperature before and after heat exchanger. Ambient temperature and engine room temperature at turbo charger inlet.
6. Parts serviced and kinds of service (adjustment, repairs, or replacement).
7. Change in operating conditions (for example, "Exhaust smoke turned black," etc.)

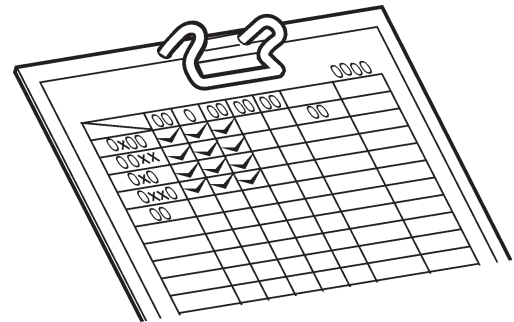

Engine

Valve Clearance

Check and adjust the valve clearance on a cold engine. The valves are adjusted according to the two stage method, but every pair of valves are also adjusted in two stages. The valve yoke is adjusted first, and then the clearance of the rocker arm.

⚠ IMPORTANT! The engine must under no circumstances be running when checking and adjusting the valve clearance since the valves can knock against the pistons and cause serious damage.

⚠ IMPORTANT! Make sure that the stop lever is pulled out and the starter key switched off.

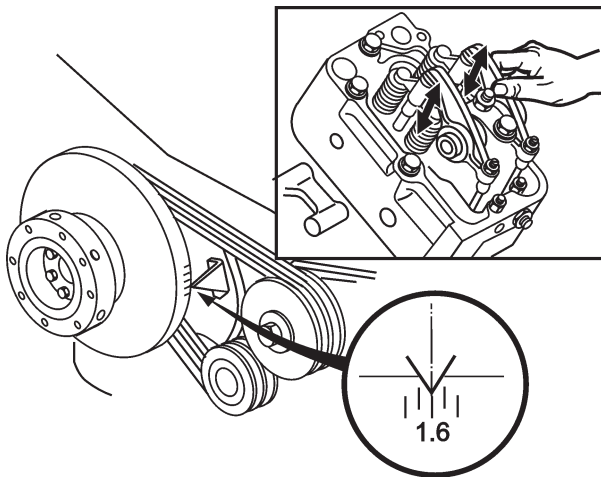

Top dead center on compression stroke

1. Turn the engine in the normal direction to align the timing mark [1.6] on the damper with the pointer as shown.
2. Remove the rocker cover of the cylinder on which the valve clearance is to be checked and adjusted, and make sure the inlet and exhaust valves have some clearance. If the timing mark [1.6] is aligned with the pointer, either the No. 1 or No. 6 piston is at top dead center on the compression stroke.

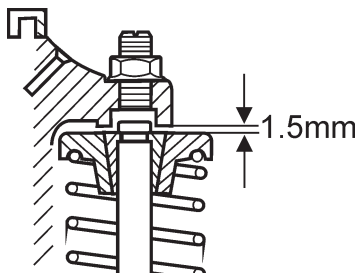

Adjust the height of valves

⚠ IMPORTANT! Make sure the clearance between the valve yoke and valve rotator is 1.5 mm [0.059 in.] or more if not, interference will occur between the yoke and rotator to cause the valve cones to get out of place. If the clearance is less than 1.5 mm [0.059 in.] after the height of valves has been adjusted, consult your dealer.

NOTE! Before inspecting the valve clearance, adjust the height of the two valves. Bring the yoke into contact with the valves, by means of the valve-yoke adjusting screw, so that there is no difference in height between the two valves. If the valve seats are worn, one valve will differ from another in height, increasing the clearance between the valve stem and yoke, leading to an increased valve clearance.

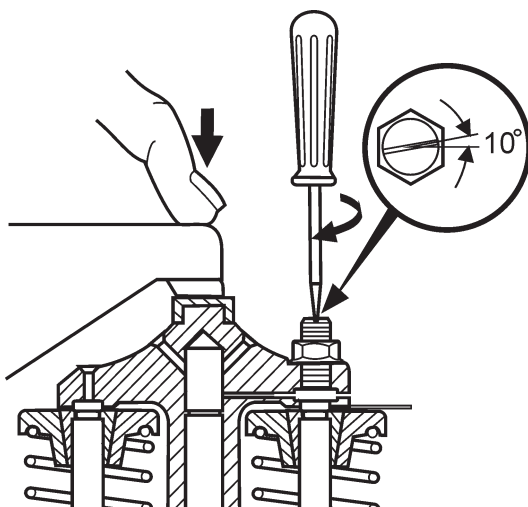

1. Unscrew the lock nut and adjusting screw on the pair of valves on the cylinder so that there is clearance between the yoke and the valve stem.
2. Press the valve yoke down. Turn the adjusting screw so that it makes contact with the valve stem.
3. Turn an additional 10 degrees. Lock the adjusting screw with the lock nut.

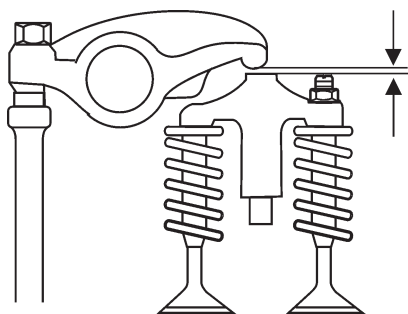

Valve clearance inspection

1. Check the valve clearance with feeler gauges inserted between the rocker arm and yoke cap.

Valve Clearance:

Inlet valve 0.4 mm [0.016 in.]

Exhaust valve 0.5 mm [0.020 in.]

2. The clearance is correct if feeler gauge is slightly gripped between the rocker arm and the yoke cap. If the feeler does not fit into the clearance exactly, perform adjustments as described below.

⚠ IMPORTANT! When performing the "First Service", valves that are checked and deemed not in need of adjustment must be checked again within 250 hours.

NOTE! Standing next to the engine, facing the cylinder head, the inlet valve is to the left and the exhaust valve is to the right

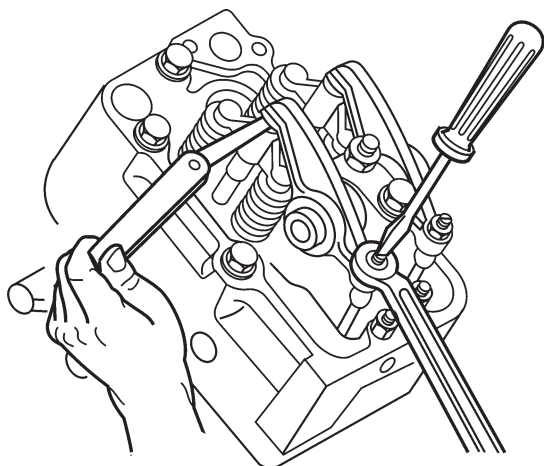

Adjust valve clearance

1. Loosen the lock nut of the adjusting screw.
2. Turn in or back off the adjusting screw so that feeler gauge is slightly gripped between the rocker arm and yoke cap.
3. After adjusting the clearance, tighten the lock nut of the adjusting screw.

Firing order

Check and adjust the valve clearance in the firing order (injection sequence), turning the engine with each cylinder piston at top dead center on compression stroke.

Firing order 1 12 5 8 3 10 6 7 2 11 4 9

(Example): After checking and adjusting the cylinder No.1, turn the engine 60° and check and adjust the cylinder No. 12.

Cylinder No.	1	12	5	8	3	10	6	7	2	11	4	9
Timing (°)	0	60	120	180	240	300	360	420	480	540	600	660

Turn the engine

Insert the turning bar in the holes on the flywheel.
Turn the engine manually.

⚠ Warning! Make sure the turning bar is removed before cranking the engine.

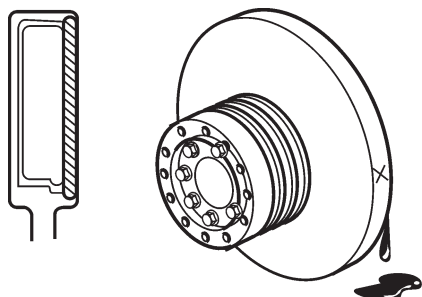

Vibration Damper Inspection

NOTE! When installing a damper protective cover on the engine, do not use a cover enclosing the damper.

Visually check for fluid leaks, flaws, distortion, or discoloration or flaking of painted surfaces. Also check for swelling (by measuring with a scale), and fluid leaks past staked portions.

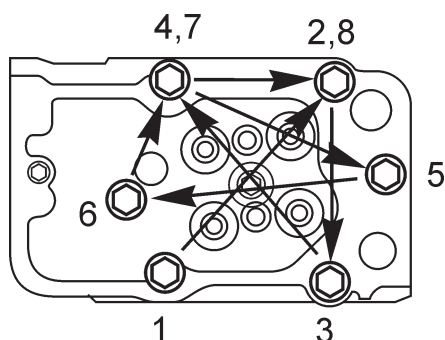

Re-tighten Bolts and Nuts

Re-tighten the bolts and nuts on the following components:

- * Timing gear case
- * Crankshaft pulley
- * Mounting brackets
- * Exhaust manifold
- * Turbocharger
- * Cylinder heads

Check the cylinder head bolts and re-tighten them in number sequence (1-2-3-4-5-6-7-8) if necessary. The tightening torques of the bolts and nuts can be found in technical data section of this manual.

NOTE! In case retightening is necessary, first unscrew the bolts completely.

Fuel system

Fuel system bleeding

Prime the fuel filters and fuel injection pump in the following sequence:

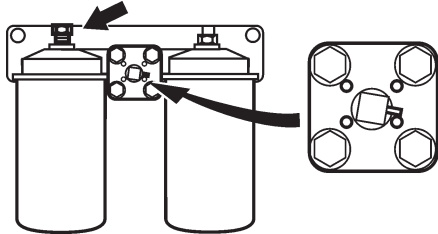

Bleeding the Fuel filter

1. Put the fuel filter switching cock in the left filter bleed position and loosen the left air vent plug.

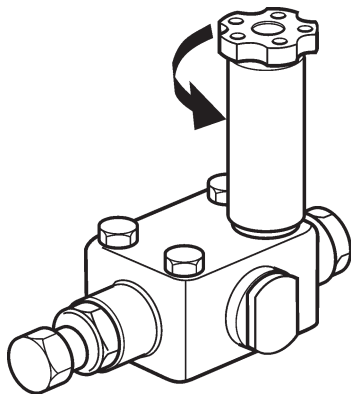

2. Turn the priming pump plunger counterclockwise to unlock the mechanism.

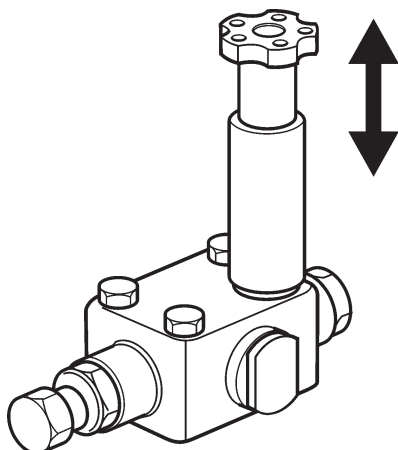

3. Move the plunger up and down until the fuel flows free of bubbles from air and tighten the air vent plug.

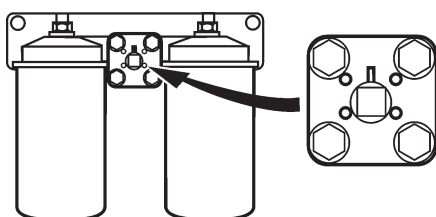

4. Put the fuel filter switching cock in the neutral position and repeat the above-described procedure for the other fuel filter.

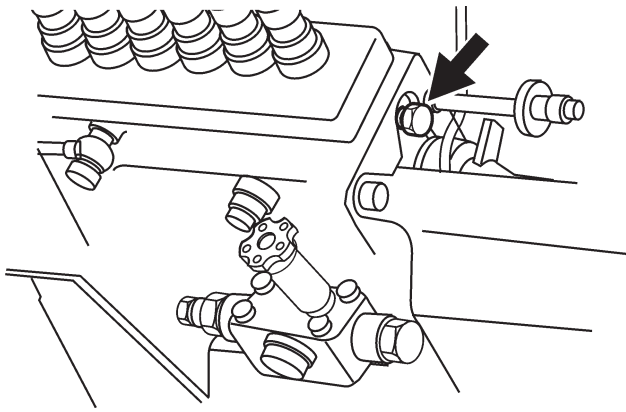

Bleeding the fuel injection pump

1. Loosen the air vent cock on the fuel injection pump about 1.5 turns.

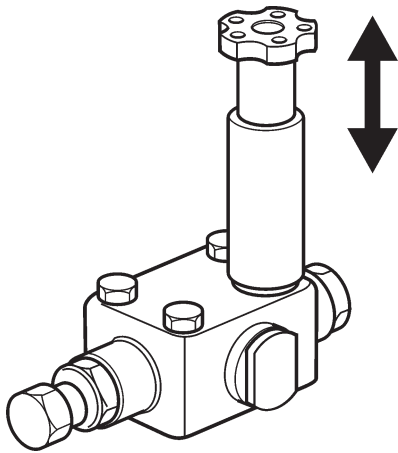

2. Move the priming pump cap up and down to start the flow of fuel through the system.
3. When the fuel coming out of the air vent cock shows no visible bubbles, lock the priming pump cap while holding it down. Then tighten the air vent cock.

Be sure to lock the priming pump cap before tightening the air vent plugs and cock. If this is not done the cap does not return to the original position due to the pressure in the priming pump.

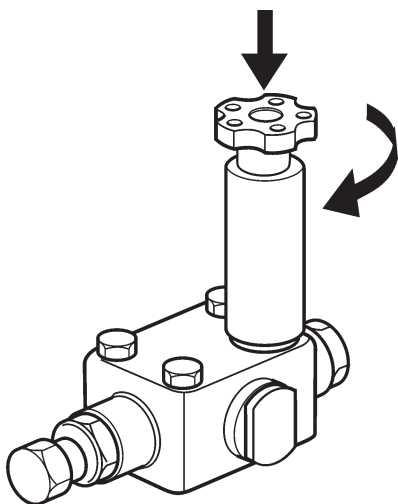

4. Tighten the priming pump cap by hand until the tightening force increases, normally this occurs after turning it approximately 70 to 90 degrees. Mark this position on the priming pump cap to make item 5 work more easily.
5. Tighten the priming pump cap an additional 120 to 150 degrees using a wrench.
6. Clean the engine from spoiled fuel to prevent fire and pollution of the environment.

- ⚠ **IMPORTANT!** If the priming pump cap is tightened too much (more than 240 degrees in total), the top of the priming pump can be damaged.
- ⚠ **IMPORTANT!** Looseness of the priming pump cap in combination with engine vibration may cause engine failure and damage to the installation.

Fuel filter change

Switchable fuel filters can be changed while the engine is running as the flow of fuel can be cut off to one filter at a time.

⚠ WARNING! Working on or approaching a running engine is a safety hazard. Beware of rotating parts and hot surfaces.

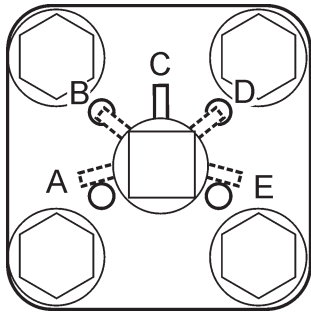

- A. Right Filter bleed position
- B. Right Filter change position
- C. Neutral position
- D. Left Filter change position
- E. Left Filter bleed position

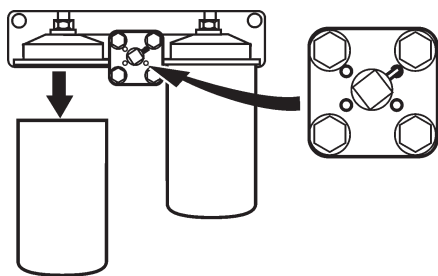

1. Place a drip pan under the fuel filter.
2. Put the fuel filter switching cock in the Left filter change position and unscrew the left-hand fuel filter. Use a filter wrench if necessary.
3. Coat the gasket of a new filter with clean diesel fuel.
4. Install the new filter in the filter bracket by hand. When the gasket contacts the base, tighten 1/2 to 3/4 of a turn more.

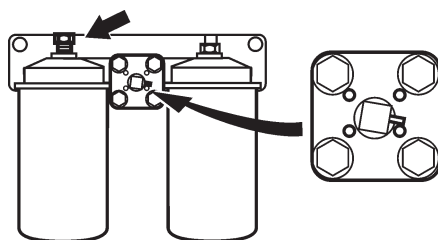

5. Put the fuel filter switching cock in the Left filter bleed position and loosen the left air vent plug until the fuel running out is free from air. Close the air vent.

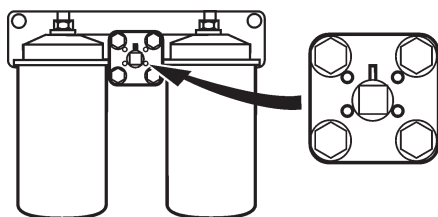

6. Put the fuel filter switching cock in the neutral position and repeat the above described procedure for the other fuel filter.

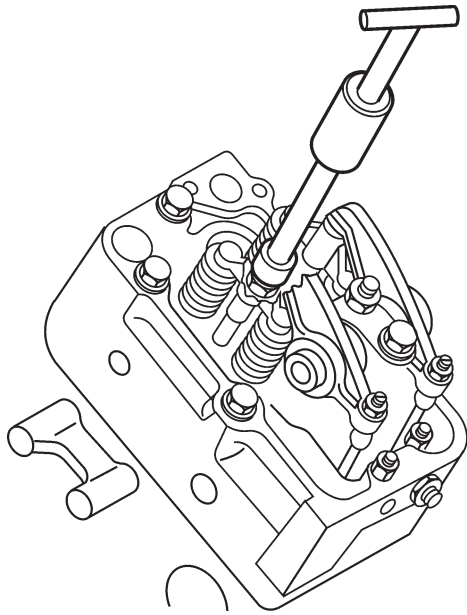

Fuel injector nozzle change

⚠ IMPORTANT! Cover all open fuel injection pipes, fuel intake openings and the fuel injection nozzle to keep dirt out

Remove the fuel injector

1. Remove the rocker cover.
2. Remove the clamp from the fuel injection pipe.
3. Remove the fuel injection pipe from the fuel injector.
4. Remove the injector inlet connector.
5. Remove the injector gland nut to take off the gland.
6. Pull out the fuel injector using the special tool.

Remove the nozzle

⚠ IMPORTANT! The injector nozzle is very delicate, handle with care.

1. Fasten the fuel injector in a vice with protection plates.
2. Remove the set screw and the cap nut.
3. Loosen the adjusting screw with a screw driver until it can be loosened by hand.

Note! This operation is required to release spring pressure applied to the nozzle. When spring pressure is applied, it is hard to loosen the retaining nut.

3. Remove the retaining nut and remove the nozzle.

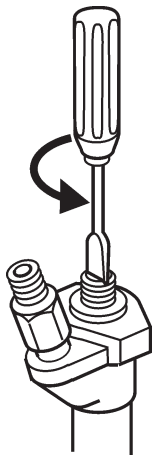

Nozzle cleaning

⚠ IMPORTANT! Do not change the pairing of needle valve and body when cleaning more than one at a time.

1. Dip the nozzle in clean fuel oil and disassemble the needle valve.
2. Clean the injection holes.
3. After cleaning, carefully insert the needle valve into the body in clean oil.

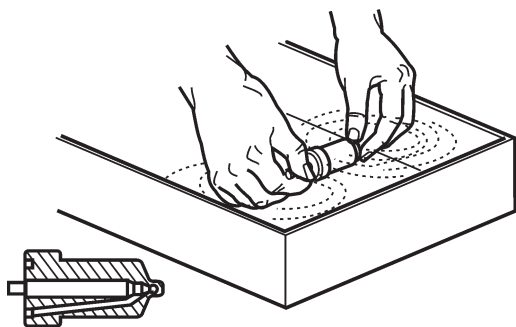

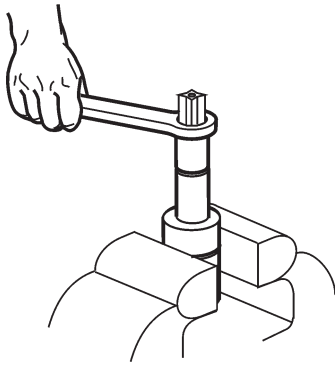

Install the nozzle

1. Install the nozzle according to the pin on the nozzle.
2. Tighten the retaining nut by applying the specified torque 177 to 196 Nm (18 to 20kpm) [130 to 145 lb.ft.]. (Apply oil to the nut.)

⚠ IMPORTANT! Do not use Moly Disulfide.

3. Adjust the nozzle opening pressure and check spray conditions.

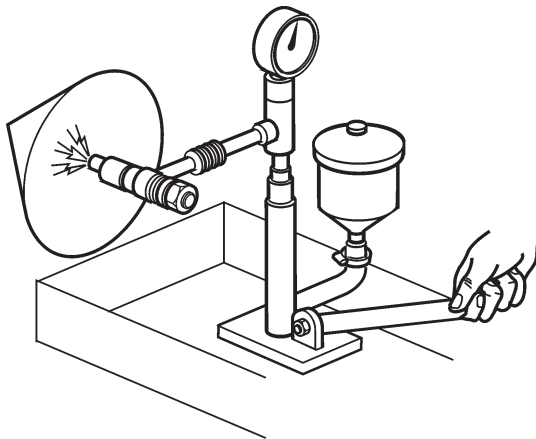

Fuel injection pressure

⚠ WARNING! Do not allow the fuel injected from a nozzle to contact the skin or body when inspecting the nozzle using a nozzle tester. The fuel injected from the nozzle has an extremely high pressure, strong enough to penetrate skin and causing serious injury.

1. Attach the fuel injector to the nozzle tester.
2. While watching the pressure gage of the nozzle tester, push the handle down slowly.

⚠ IMPORTANT! If fuel drips from the end of the nozzle tip it must be replaced.

3. When the handle is being pressed down, the fuel is injected, and the pressure on the pressure gage drops suddenly. The pressure value indicated at this point is the fuel injection start pressure.
4. Close the valve on the injection pump. If the pressure on the gage drops too fast (most probably due to leakage) the nozzle must be replaced.

NOTE! Make sure it isn't the injection pump itself that is leaking.

Nozzle opening pressure

21.57 MPa (220 kp/cm²) [3130 psi]

Fuel injection nozzle spray pattern

Check spray conditions when checking fuel injection pressure. Good spray conditions are as follows:

- Fuel is injected from all nozzle holes.
- The fuel is sprayed in a conical shape.
- No big particles but fine ones.
- No oil drip is left after injection.

If the nozzle fails to spray fuel properly, replace with a new one.

NOTE! Fuel injection pressure and nozzle spray pattern check intervals may be extended in steps of 250 hours if they are ok at 1000 hrs.

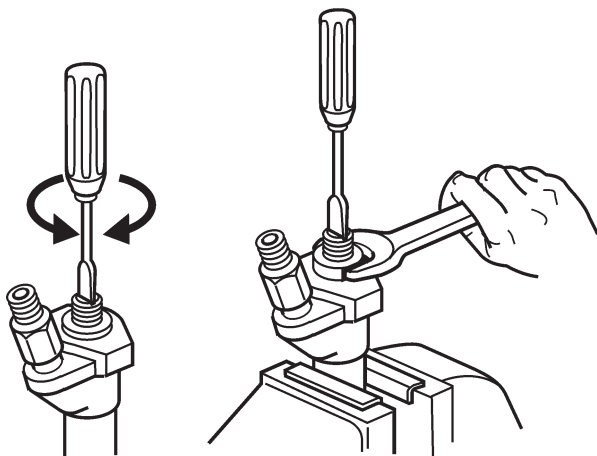

Adjust the fuel injection pressure

1. To adjust injection pressure, remove the cap nut from the nozzle holder, and then turn the adjusting screw. To increase the injection pressure, tighten the screw. To decrease the injection pressure, loosen the screw.
2. When the pressure meets the standard value, tighten the cap nut to 39 - 49 Nm (4 - 5 kpm) [29 - 36 lbf.ft].
3. Tighten the set screw to 15 - 20 Nm (1.5 - 2 kpm) [11 - 15 lbf.ft].

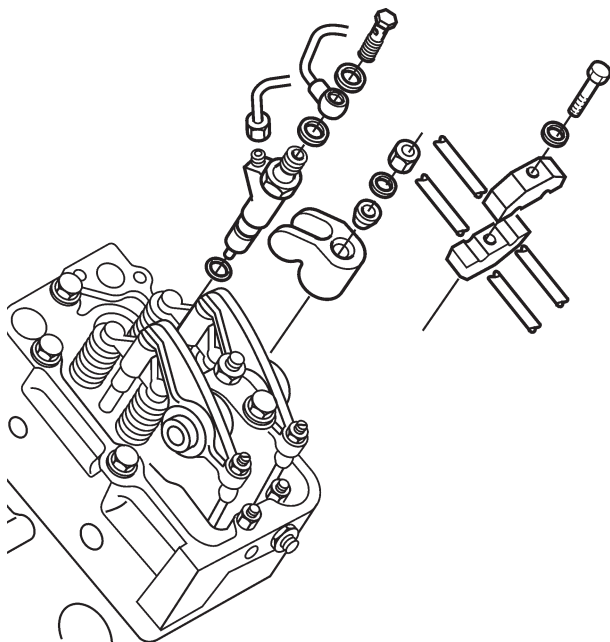

Fuel injection nozzle installation

1. Attach a nozzle gasket to the fuel injector nozzle.
2. Insert the fuel injector into the cylinder head.
3. Install the nozzle gland and tighten the nut to 78 Nm (8.0 kpm) [58 lbf].
Use new sealing washers when securing the fuel injection pipe and fuel return pipe.
4. Tighten the fuel return hollow screw to 15 - 20 Nm (1.5 - 2 kpm) [11 - 15 lbf.ft].
5. Before mounting the rocker cover, operate the engine at approx. 700 rpm and check for fuel leaks. Install the rocker cover.

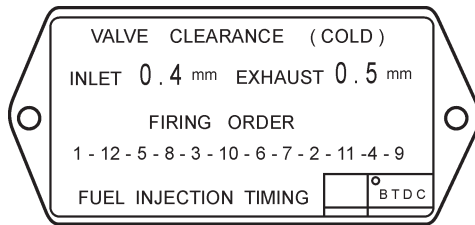

Injection timing inspection

The injection timing is indicated on the caution plate attached to the No. 1 rocker cover. Check it before inspection. Bring the piston for No. 1 cylinder to top dead center on compression stroke as follows:

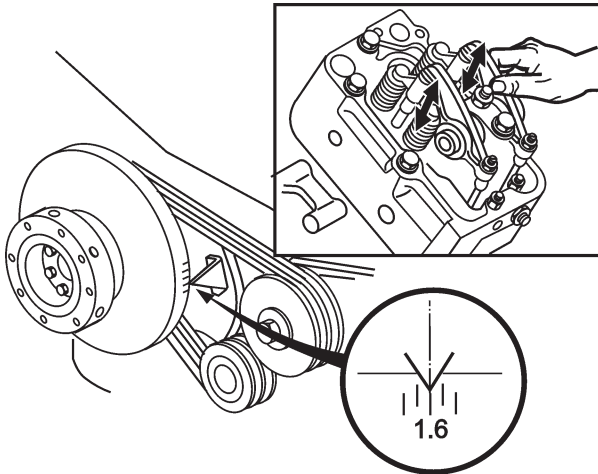

1. Turn the engine in the normal direction to align the timing mark [1.6] on the damper with the pointer as shown.
2. Remove the No. 1 rocker cover and make sure the inlet and exhaust valves for No. 1 cylinder have some clearance. If these valves have no clearance, turn the engine once again to align the timing mark [1.6].

NOTE! Do not confuse the No. 1 cylinder with No. 6. When the piston for the No. 1 cylinder is in the above-mentioned position, its inlet and exhaust valve are seated, presenting some clearance.

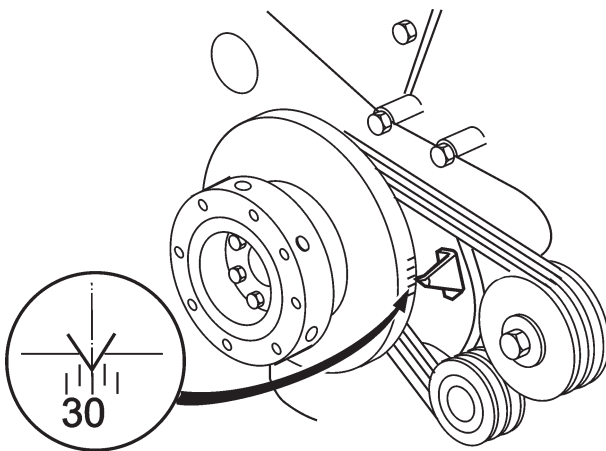

3. Turn back the engine approximately 60 degrees, and turn it in the normal direction slowly until the specified timing (indicated on the caution plate) aligns with the pointer.

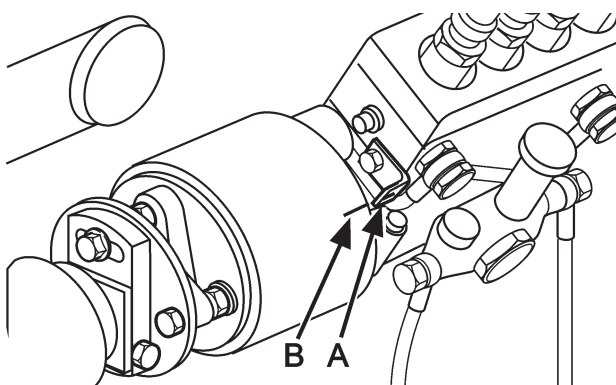

4. To ensure proper injection timing, make sure that the timing mark (B) on the fuel pump flywheel aligns with the pointer (A) on the fuel injection pump.

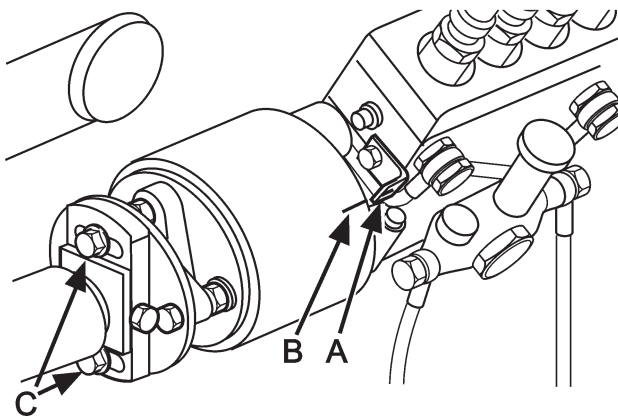
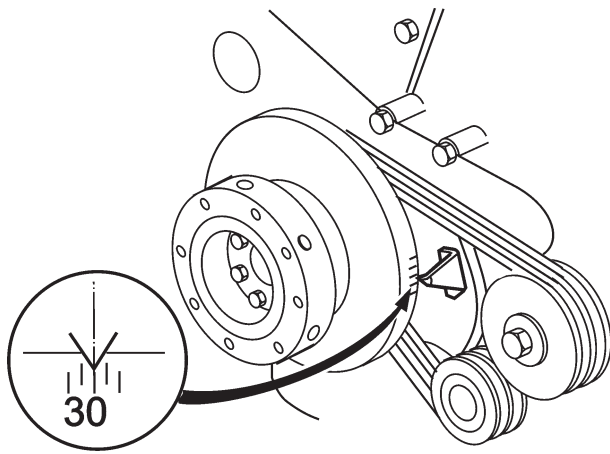

Adjust fuel injection timing

1. Make sure the timing mark (indicated on the caution plate) is aligned with the pointer, with the piston for the cylinder at top dead center on compression stroke.
2. Loosen the bolts(C) for the fuel injection pump coupling.
3. Turn the fuel pump flywheel until the timing mark(B) on the flywheel aligns with the pointer(A) on the fuel injection pump.
4. Tighten the one nut for fuel injection pump coupling. Turn the engine to tighten the other side nut.
5. Turn the engine (two turns) to recheck the injection timing for verification.

Check fuel control

Fuel control link joints inspection

Check the ball joints for play. If there is more than 0.1 mm [0.004in.] play, replace the ball joints with new ones.

⚠ WARNING! In case of a control link having ball joints that is an integral part of the link, change the link as an assembly.

Injection pump control rack operation

Move the stop lever back and forth a few times and find out if the control rack can be operated smoothly.

⚠ WARNING! If the rack sticks this must be fixed before starting the engine.

⚠ WARNING! Never try to control the engine rpm by moving the manual stop control lever in the opposite direction of the arrow. This can result in serious harm of the installation.

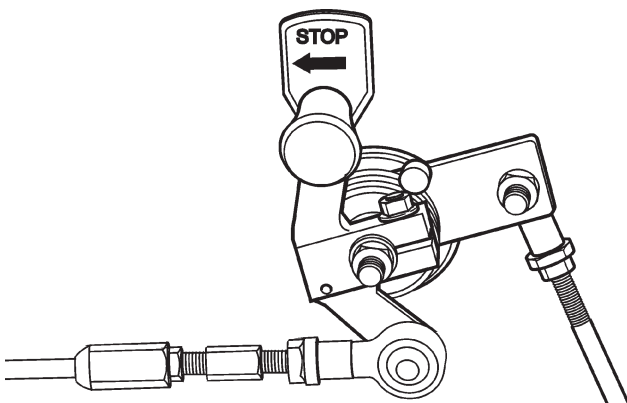

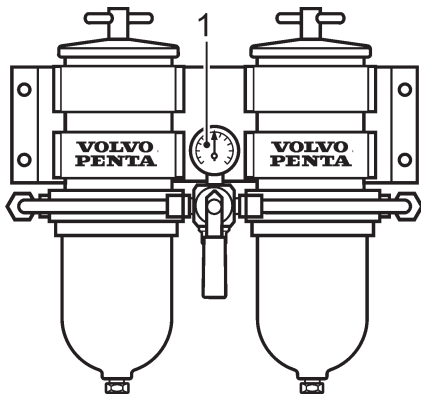

Twin fuel pre-filter/water separator

⚠ WARNING! Working on or approaching a running engine is a safety hazard. Beware of rotating parts and hot surfaces.

The dual filter is equipped with a pressure gauge (1) indicating when it is time to change the filter insert. The filter inserts must be changed according to the maintenance schedule recommendations or earlier if the pressure gauge indicates a vacuum of 6–10 inHg at idling speed or 16–20 inHg at full engine speed/load.

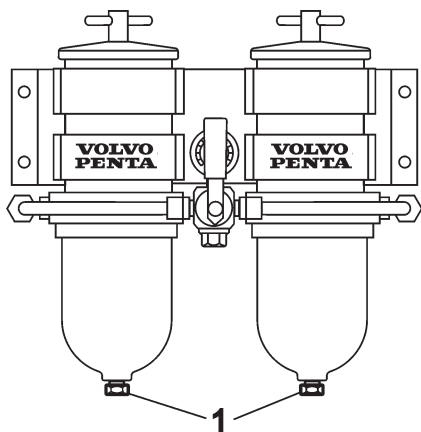

Drainage

Place a drip pan under the filter. Drain off water and contaminants through the plug (1) in the bottom of the bowl.

⚠ IMPORTANT! Do not drain until a few hours after stopping.

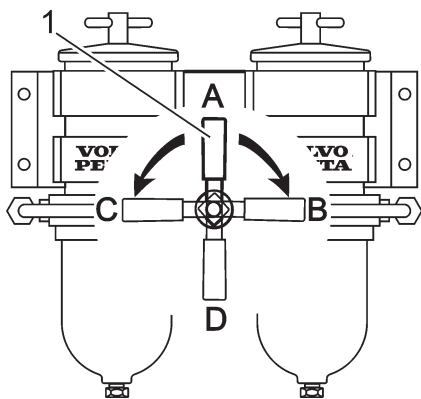

Change the filter elements

The dual filter inserts can be changed while the engine is running as the flow of fuel can be cut off to one filter container at a time.

The flow of the fuel is governed by turning the handle (1) in the following positions:

- A: Normal running (both filters connected).
- B: Left filter insert can be changed.
- C: Right filter insert can be changed.
- D: Both filters turned off.

Close the fuel cocks on the tank before changing filters. If the engine is running cut off the flow of fuel with the handle (1) on the filter itself.

⚠ WARNING! Working on or approaching a running engine is a safety hazard. Beware of rotating parts and hot surfaces.

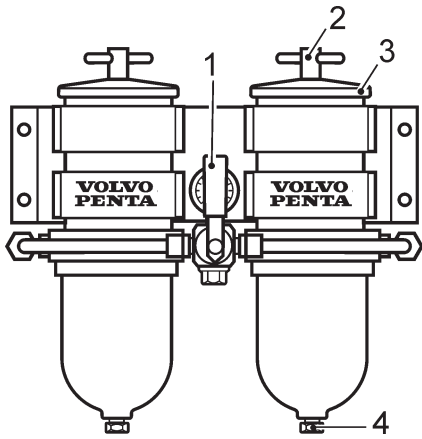

1. Place a drip pan under the filter.
2. Undo the T-bolt (2) and remove the cover (3).
3. Take out the insert carefully while turning it.
4. Drain off water and contaminants through the drain plug (4).
5. Fit a new filter insert and fill the container with clean fuel.

⚠ IMPORTANT! Cleanliness! No contaminants must be allowed in the fuel system.

6. Change the gasket on the cover and the O-ring on the T-bolt. Moisten the gasket and O-ring with fuel before assembling.
7. Fit the cover and tighten it by hand.
8. Wipe off any fuel from the filter cover and housing.
9. Dual filter: Change the other filter insert in the same way.
10. Open the fuel cocks and turn the handle (1) in position for normal running. Make sure there are no leaks.

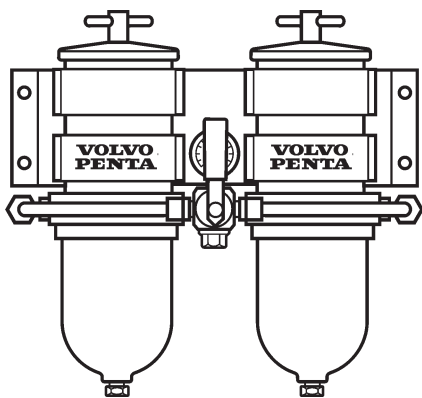

Lubrication system

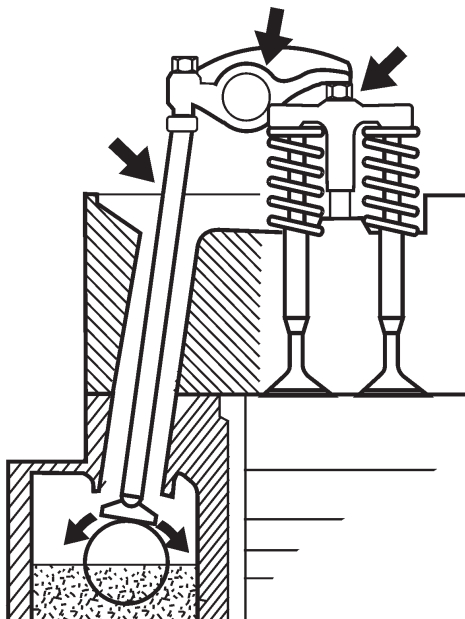
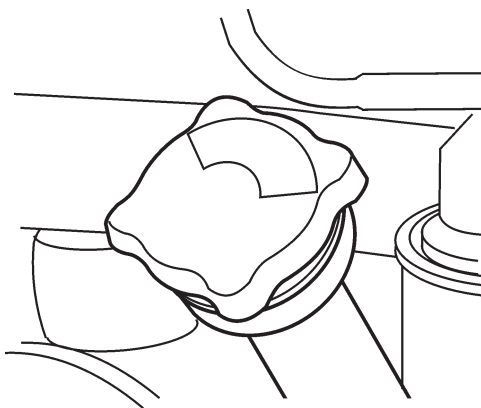
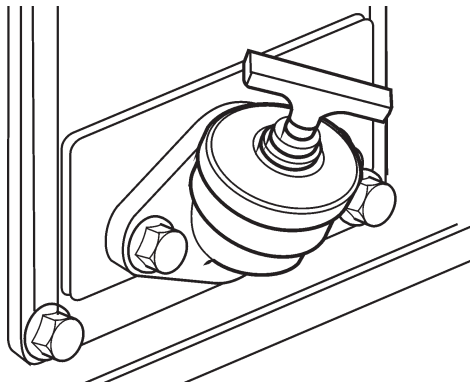

Lubrication oil level check

The oil level must be within the marked range on the dipstick and must be checked daily.

⚠ IMPORTANT! The level must never be allowed to drop beneath the minimum or rise above the maximum mark on the dipstick.

Lubrication oil filling

Fill the engine with lubrication oil through the filler pipe. For oil specification refer to chapter technical data. The oil level should be within the marked area on the dipstick. After filling oil, secure filler cap.

⚠ WARNING! Lubrication oil on hot surfaces or electrical components may cause fire. Do not smoke while filling oil or when handling oil containers.

⚠ IMPORTANT! Stop the engine when filling oil.

⚠ IMPORTANT! Avoid mixing oils of different brands, additives used in the oils can cause chemical reactions that may degrade the oil performance.

⚠ IMPORTANT! The lubrication oil level must never be allowed to drop beneath the lower, or rise above the maximum, mark on the dipstick.

Filling oil in new or reconditioned engine

If your engine is new or reconditioned you should besides the actual filling of new lubrication oil also do the following:

1. Remove the rocker cover. Lubricate the valve mechanism and fill the camshaft oil bath from the cylinder head. Repeat the procedure for each cylinder.
2. Mount all the rocker covers. Refer to section Tightening torques for proper torques.

NOTE! Avoid running or cranking the engine without the rocker covers mounted.

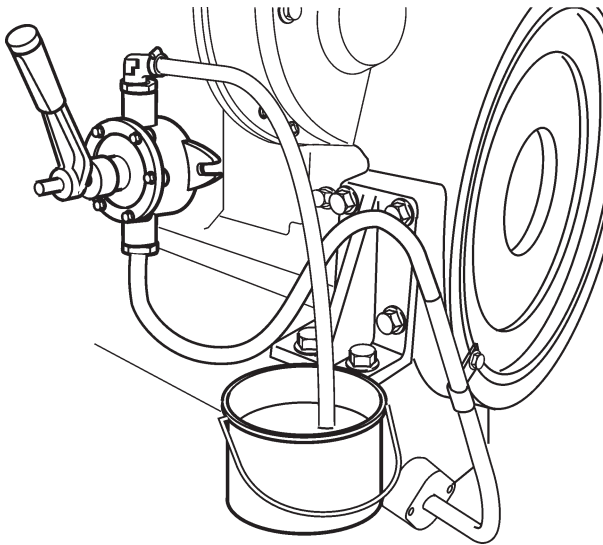

Lubrication oil change

Always observe the recommended oil change interval.

⚠ IMPORTANT! Only use recommended grades of oil (see chapter technical data).

1. Warm up the engine (this makes it easier to suck the oil up from the sump). Then stop the engine.

⚠ WARNING! Hot oil and hot surfaces may cause burns.

2. Connect a hose to the outlet pipe of the lubrication oil scavenging pump. Pump the oil out.

NOTE! Collect the old oil and filters and deposit in accordance with local regulations. Never dispose of old oil or oil filters overboard.

3. Change the oil filters and the by-pass filter (if applicable) at every oil change (please refer to section oil filters change).
4. Fill with oil to the correct level through the oil filling pipe.

5. Start the engine and allow it to idle. Check the oil pressure and make sure that there are no leaks by the filters.

⚠ WARNING! Approaching or working with a running engine is a safety risk. Be careful to avoid rotating components and hot surfaces.

6. Stop the engine. Wait a few minutes before you check the oil level. Top up if necessary.

Oil filter change

Each pair of filters has its own shut off valve located on the housing between the filters. The oil filters can be changed while the engine is running as the oil flow can be directed through two filters at a time.

⚠ WARNING! Always keep all four filters in operation under normal operating conditions.

⚠ WARNING! Reduce the engine speed to idle when changing oil filters on a running engine.

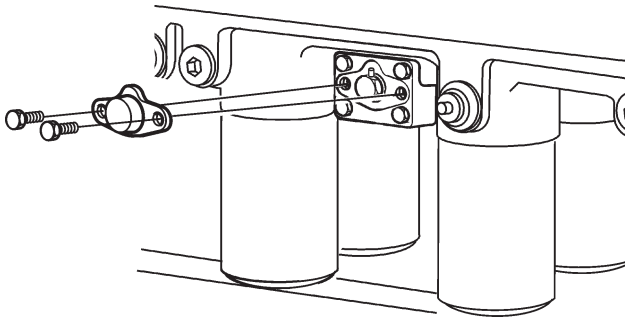

1. Remove the cover from the filter switch valve by disconnecting the two bolts.

⚠ WARNING! Working on or approaching a running engine is a safety hazard. Beware of rotating parts and hot surfaces.

2. Cut off the oil flow through the right filters by turning the setting valve in position C.
3. Unscrew the oil filter using the special tool. Discard the filter.

NOTE! Place a drip pan beneath the filter when removing to avoid oil spill.

4. Lightly oil the new filter's rubber gasket and check its mating surface on the mounting.

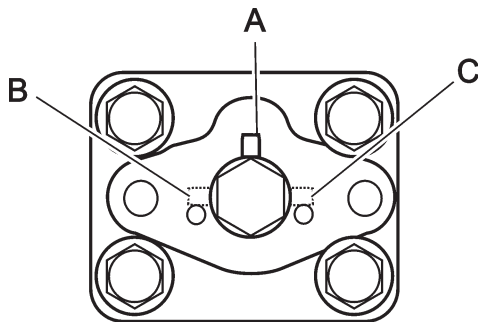

A: Normal running (all filters connected).

B: Left filters can be changed.

C: Right filters can be changed.

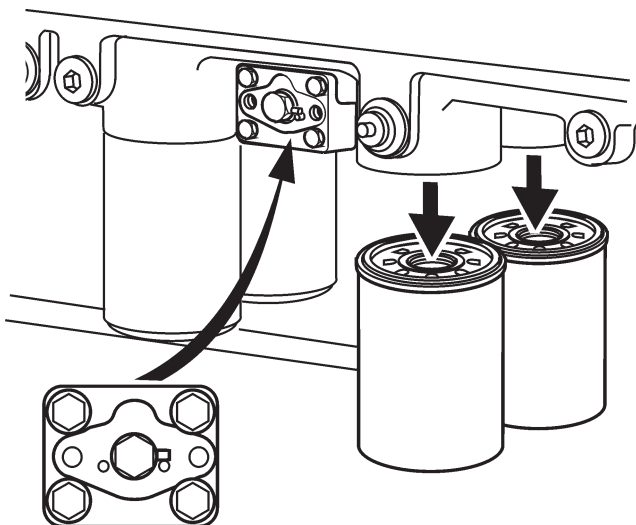

5. Mount the new filter by hand until the gasket is in contact with the sealing surface. Then tighten the filter a further approximately 3/4 of a turn.
6. Put the filter on-line by turning the valve in position A.
7. Replace the left filters as above. Position B is the left filters change position.
8. Replace all four full-flow filters at the same time.

NOTE! After a lubrication oil filter change, open the filter and check for metal parts.

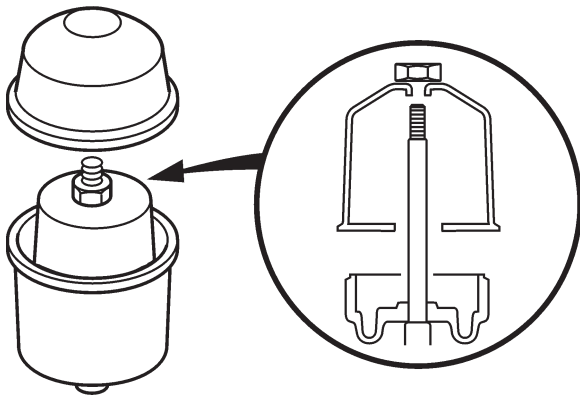

Clean centrifugal by-pass oil filter

Remove the cover and clean inside with clean diesel.

NOTE! In case by-pass filter is very dirty, shorten check interval, refer chapter Maintenance schedule.

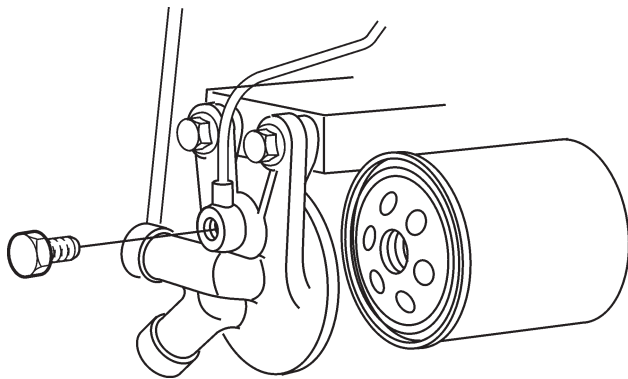

Hydraulic governor oil filter change

1. Place a drip pan under the governor oil filter.
2. Remove the governor oil filter with a filter wrench.
3. Clean the gasket for the new filter and coat it with clean engine oil.
4. Fit the new filter and tighten it by hand.
5. Remove the air vent plug and fill filter with engine oil. Reinstall the plug.
6. Operate the priming pump or the wing pump to circulate engine oil. Check for leaks, tighten filter if necessary.

Check the oil

After an oil change always check the oil. Smell it for strange smells and visually check it for the presence of fuel or water.

Freshwater system

The Freshwater system is the internal cooling system. It is a closed system and must be filled with a coolant that protects the engine from internal corrosion and freezing. Anti-corrosive additives become less efficient with age and the coolant must therefore be changed in accordance with the recommendations in the maintenance schedule.

- ⚠ **WARNING!** Never open the pressure cap when the engine is warm. Steam or hot fluid may spurt out.
- ⚠ **WARNING!** The coolant is dangerous to your health and an environmental hazard. Handle coolant with care and dispose of old coolant in accordance with local regulations.
- ⚠ **IMPORTANT!** For coolant specification, refer to chapter “technical data” in the back of this manual.
- ⚠ **IMPORTANT!** Check the coolant level on a cold stationary engine.
- ⚠ **IMPORTANT!** Coolant to be added should have the same concentration as the coolant in the engine. Do not add plain water.
- ⚠ **IMPORTANT!** Certain parts of the system are made of light alloy. Chemical additives must therefore not be used when cleaning.

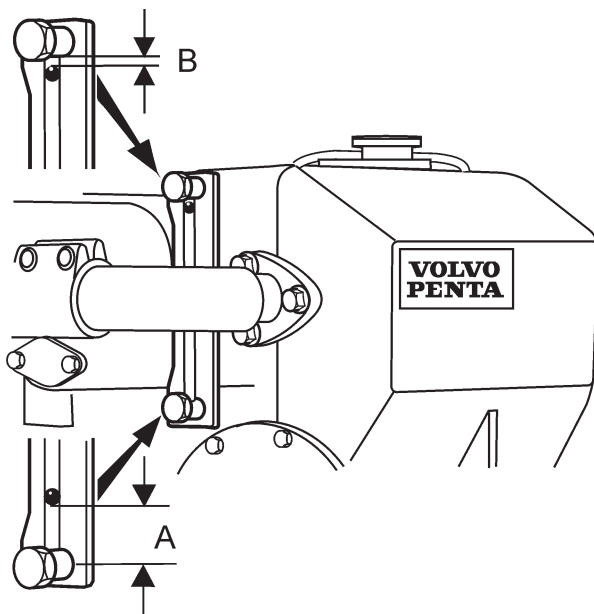

Coolant level check

MS engines

Make sure the level is between the MIN and MAX marks. If there are no marks, the coolant level should be approximately 5 cm below the top of the filler cap. For coolant specification, refer to chapter “technical data” in the back of this manual.

MT engines

The minimum cooling water level on a cold engine is 175 mm [from the bottom of the sight glass and up (A)].

The cooling water level of a cold engine must never reach higher than 5 mm below the top of the sight glass (B). For coolant specification refer to chapter “technical data”.

Coolant filling

Topping up

Fill the freshwater system with coolant to the correct level through the filler opening in the expansion tank. For correct coolant level, refer to section "coolant level check". Fill slowly so that the evacuated air is able to pass the filler opening.

Filling when the system is empty

1. Open the air ventilation cocks and close the coolant drain cocks.
2. Make sure that systems connected to the cooling system also are ventilated, e.g. coolers, water heater, etc.
3. Fill the freshwater system with coolant to the correct level through the filler opening in the expansion tank. For correct level, refer to section "coolant level check". Fill slowly letting air bleed from the ventilation cocks and the filler opening. When air-free coolant flows out, close the ventilation cocks.
4. To bleed the system, open all air vent cocks and crank the engine for 10 seconds while holding the emergency stop lever in stop position. Repeat several times at one minute intervals.
5. Close air vents. Check the coolant level and top up if needed.

 **IMPORTANT!** Make sure that the engine is filled with lubrication oil before starting or cranking the engine.

 **IMPORTANT!** The engine must not be started before the system has been bled and topped up.

6. Start the engine and run it under light load until the thermostat valve opening temperature is reached.
7. Check air vents for leaks.
8. Stop the engine and allow it to cool. Check the coolant level in the expansion tank and top up if needed.

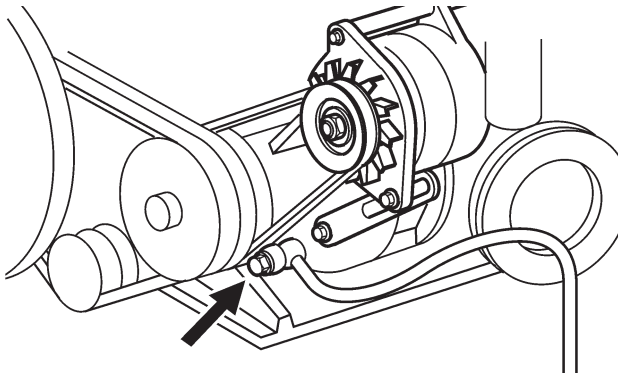

Coolant drain

1. Remove the filler cap on the expansion tank.
2. Open the air vent cocks and then drain the coolant from the drain cocks.

⚠ IMPORTANT! Check that the coolant really drains. Deposits may need to be removed from inside the drain plugs/taps.

3. Drain all systems connected to the freshwater system, e.g. heater, water heater, etc.
4. Close all drainage points.

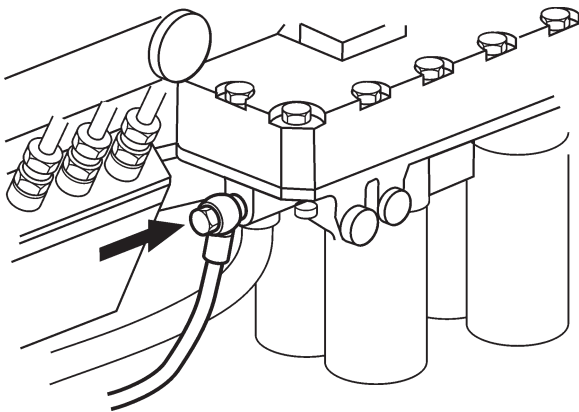

Freshwater system flushing

The system should be flushed before changing coolant to avoid inferior cooling performance due to deposits in the cooling system.

1. Drain the coolant as described earlier.
2. Insert a hose into the filler opening and flush with fresh water.
3. Flush until the water running out of the drainage points is clean.
4. Close all drainage points when the flushing water has run out.
5. Fill with coolant. See section coolant filling when empty.

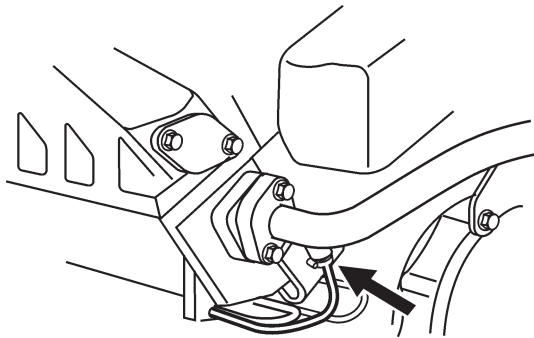

Seawater system

The seawater system is the engine's external cooling system. It cools the internal cooling system in an engine mounted or externally mounted heat exchanger. The system is protected against galvanic corrosion by zinc anodes located in the heat exchanger.

⚠ WARNING! The seawater cocks and/or the cocks of the external cooling system must be closed before commencing work on the seawater system. This due to the risk of sea water entering the vessel.

Draining the seawater system

1. Close the seawater in- and outlet cocks.
2. Drain the coolant from the external cooling system.

⚠ IMPORTANT! Check that the coolant really drains. Deposits may need to be removed from inside the drain plugs/taps.

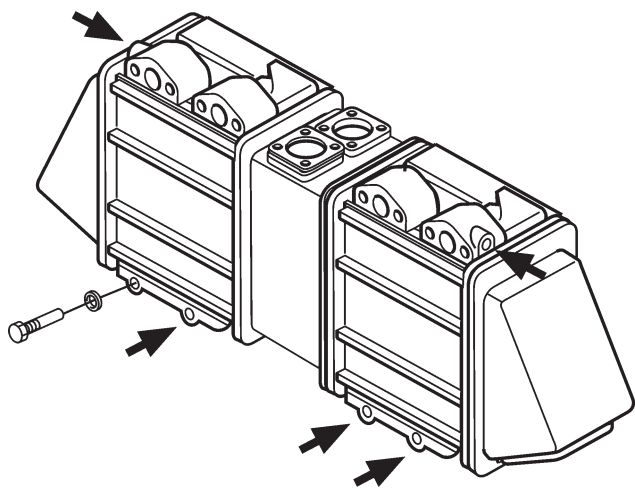
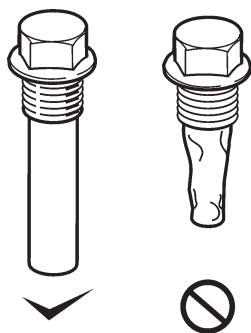

Check and Change the zinc anodes

1. Drain the external cooling water as described in the chapter draining the seawater system.
2. Unscrew the zinc anodes from the heat exchanger.
3. Clean the anode with emery cloth to remove the layer of oxide. Change the anode if less than 50% remains.

⚠ IMPORTANT! Do not use a wire brush or other metal tool for cleaning as this may decrease the galvanic protection.

4. Fit the zinc anodes. Make sure there is good contact between the anode and the metal goods.
5. Open the seawater cocks before starting the engine
6. Check the installation and make sure there are no leaks.

Seawater filter check/change

For the seawater inlet filter we refer to the maintenance description supplied by the supplier of the filter.

NOTE! If the water wherein the vessel operates is severely polluted, contains large amounts of seaweed, etc., the filter must be checked more often than is specified. The filter can otherwise become clogged and the engine overheated.

Seawater pump impeller check/change

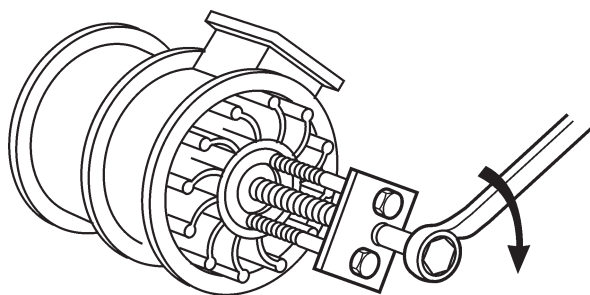

⚠ IMPORTANT! Always keep a spare impeller and gasket in store aboard the ship.

1. Drain the external cooling water as described in the chapter draining the seawater system.
2. Remove the pump end cover. Remove the impeller using a puller, remember direction of rotation.
3. Inspect the impeller. Change the impeller if there are any visible cracks or other defects.
4. Clean the inside of the housing.
5. Put some grease on the impeller blades and push the impeller into position while rotating it in the normal operating direction.
6. Fit the cover with a new o-ring or gasket.

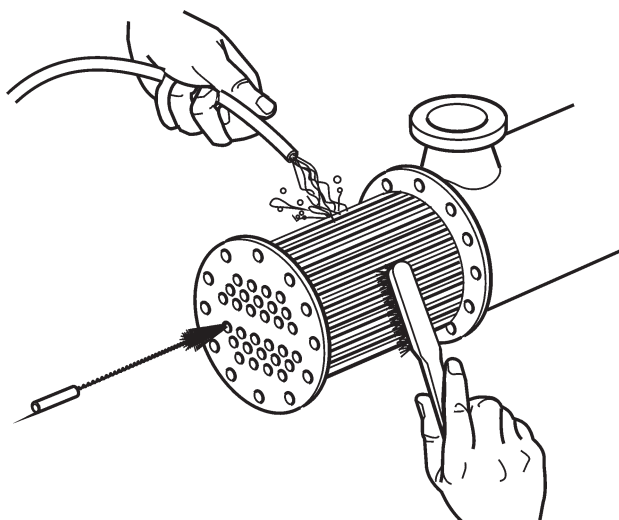

Heat exchanger cleaning

Clean if there are signs of clogging, a gradual increase in engine temperature or high seawater pressure. Check/clean the seawater filter first. Check also the seawater pump impeller.

1. Drain the external cooling water as described in the chapter draining the seawater system.
2. Detach the pipe connections from the heat exchanger.
3. Remove both covers from the heat exchanger
4. Clean the heat exchanger tubes using suitable brushes while flushing the tubes with water
5. Refit the heat exchanger element and mound the covers.
6. Connect the pipe connections to the heat exchanger. Check gaskets and change if necessary.
7. Open the seawater cocks. Fill the freshwater system.
8. Start the engine and make sure the seawater system is not leaking.

Air Inlet and Exhaust Systems

Turbocharger Inspection

⚠ WARNING! Check the turbocharger only when the engine is cool and the compressor wheel is not rotating.

Check shaft play, take a hold of the compressor wheel nut and turn the wheel to feel rattle and listen for abnormal noise. Replace the bearings if the wheel is noisy or rattles.

NOTE! Also check the turbocharger when the exhaust color is abnormal.

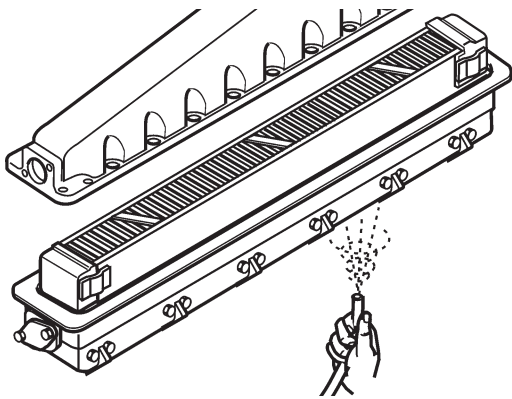

Cleaning the Air Cooler

1. Remove the air cooler.
2. Blow compressed air through the air cooler in the direction opposite to normal air flow. Max press. is 0.49 MPa (5kpm) [71 psi].
3. Check cooler for corrosion and cracks.
4. Wash the fresh water tubes in water then remove scale deposits by inserting an 8 mm bar into each tube.
5. Replace zinc rods if sea water is used in the cooler.

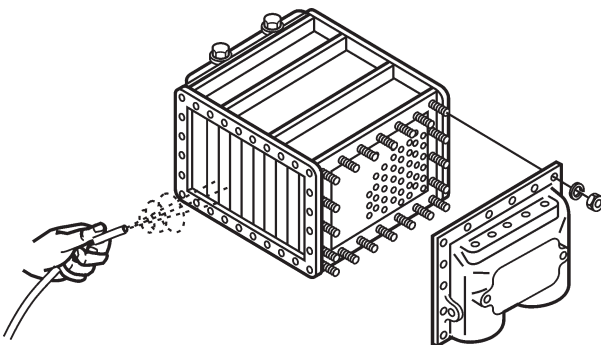

Check air cooler drain pipe

Make sure the drain from the air cooler is not clogged.

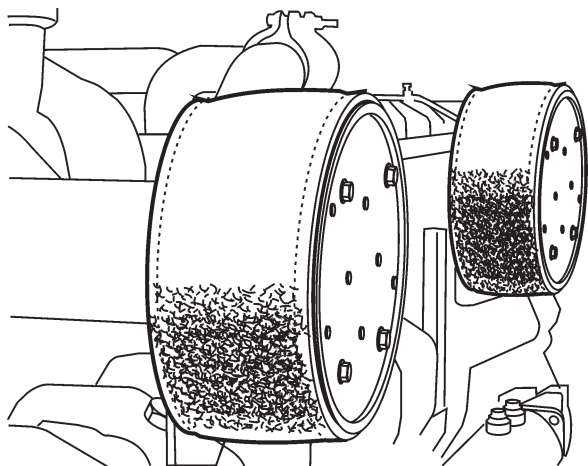

Wash the air filter

Remove dust from the air filters on the suction side of the turbocharger silencers. Be sure to keep the air filters clean to ensure optimum engine performance.

1. Remove the air filter from the silencer, and hand-wash with a mild detergent.
2. Rinse the air filter with clean water.
3. After drying thoroughly, reinstall the air filter in the silencer.
4. Repeat the procedure on the other airfilter.

NOTE! If the air filter is damaged it must be replaced.

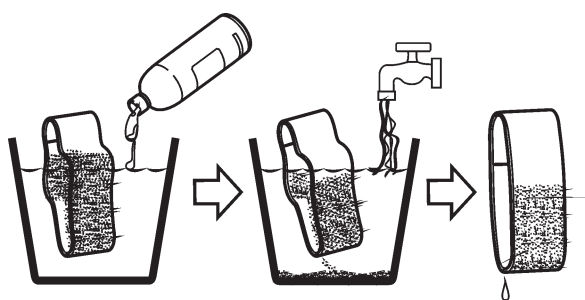

Electrical system

Protective Devices Inspection

Make sure that the instruments and the alarm functions of the engine control system work properly.

Check the electrical wiring

Check for loose or damaged electrical cables. Damaged cables must be replaced.

Starter motor inspection

1. Visually inspect the starter motors for damages and dirt build-up. Repair and clean if needed.
2. Check the pinion for shifting and meshing action. If the starters has a defect, consult your dealer.
3. Check if the clutch of the starter motors operates smoothly.

Alternator Inspection

1. Inspect the alternator on functionality and clean it if needed.
2. Remove the V-belt from the alternator. Turn the alternator pulley by hand to check the rotation. If the alternator has a defect, consult your dealer.

Drive belts. Check/Adjust/Change

⚠ WARNING! Stop the engine before commencing maintenance work.

Check belt tension and condition regularly. If the belt is too tight it can damage bearings and if it is too loose it may slip. Check and adjust after operation when the belt is warm.

The belt is correctly tensioned when it can be depressed approximately 10 mm between the pulleys. Clean the belt grooves before fitting a new belt.

⚠ IMPORTANT! Always change a belt that appears worn or is cracked (belts working in pairs must be replaced together).

⚠ IMPORTANT! Always keep the belts clear of oil or grease. Oil or grease can cause the belts to slip, which might shorten belt life.

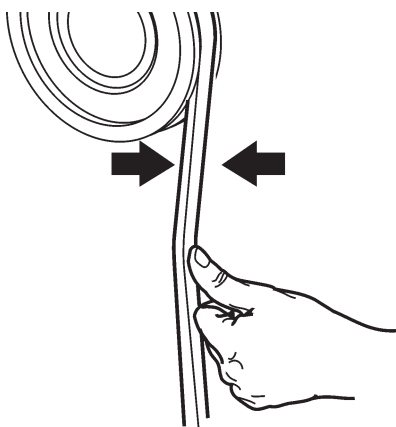
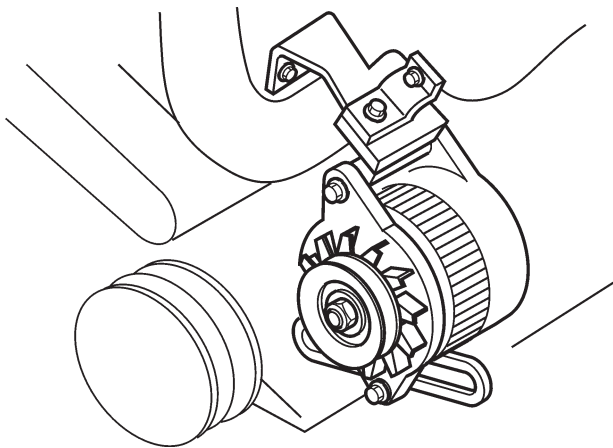
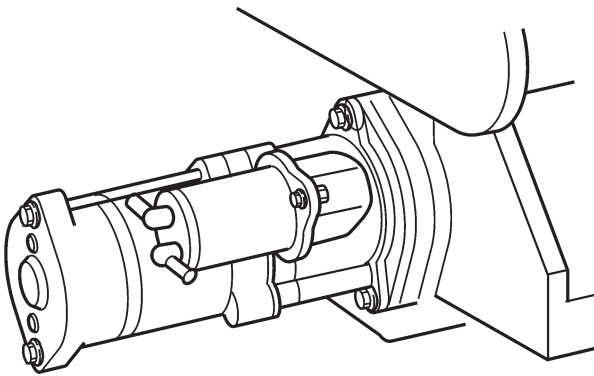

Inhibiting

General

To prevent the engine and other equipment from being harmed during long (2 months or more) periods out of service, it must be conserved. It is of utmost importance that the conservation is performed correctly. Therefore we have compiled a checklist of the most important points. Before taking the engine out of service for long periods, it should be checked by a Volvo Penta dealer for possible needed overhaul or repair of the engine and other equipment.

⚠ WARNING! Read the chapter "Maintenance" thoroughly before starting any maintenance work. It contains directions for performing maintenance in a safe and correct manner. Certain preservatives are flammable. Some are also dangerous to inhale. Provide good ventilation. Use a protective mask.

⚠ IMPORTANT! The following must be considered when cleaning with a high-pressure water jet: Never point high-pressure water jets directly at seals, rubber hoses or electrical components. Never use the high-pressure function when washing the engine.

Preparation

1. Drain the lubrication oil from the engine and fill it with new lubrication oil or conserving oil.

⚠ IMPORTANT! Post a warning sign on the engine that the conserving oil must be replaced with the specified lubrication oil before starting the engine again.

2. Run the engine on idling speed on a mixture of 70% fuel and 30% lubrication oil until the complete fuel system is filled with the mixture, then stop the engine (If possible, top up the fuel tank to avoid condensation).
3. When the engine is coming to a stop but is still rotating, spray volatile rust preservative in the air intake and exhaust system. This to prevent rust on the intake system.
4. Apply a coat of rust preservative to the exposed, machined surfaces of the engine.
5. Cover breather, air inlet and exhaust openings with tape.
6. Loosen the alternator and water pump drive belts.
7. Tape the starter and alternator terminals and cover the starter and alternator with a polyethylene sheet. Put a desiccant inside the covering.

⚠ IMPORTANT! Never use vinyl sheets for covering. This can result in condensation and harm the installation

8. Remove the batteries and charge them. Clean the terminal posts and coat them with acid free Vaseline. Keep the batteries in a dry, cool place.
9. Cover the engine for weather protection.

⚠ IMPORTANT! Store the engine in a well-ventilated room.

⚠ IMPORTANT! It is not necessary to drain the coolant because it contains coolant conditioner.

Care during Storage

Recharge the battery at least once a month.

⚠ IMPORTANT! During longer periods out of operation, the preparations must be repeated every 12 months.

Return the Engine to Service

1. Remove the covering from the engine.
2. Connect well-charged batteries to the engine.
3. Remove the covering from the starter and alternator.
4. Adjust the alternator and water pump drive belts.
5. Remove all coverings and tapings.
6. Drain the rust preservative from the engine and fill the engine with recommended engine oil.
7. Fill the fuel tank and prime the fuel system.
8. Check under and around the engine for such items as loose or missing bolts, oil, fuel or coolant leaks and repair if needed.
9. Remove the rocker covers and lubricate the valve mechanism.
10. Crank the engine three times, 10 seconds each time, at intervals of one minute, with the fuel supply shut off, to make sure the oil pressure rises properly.
12. Start the engine.
13. Allow the engine to warm up at low idle.
14. When the engine has run long enough to warm up apply the load and bring it to operating speed.

Storage of Engine in Operating Condition

Service the engine once a month in the following manner:

1. Crank the engine two times, for 10 seconds each time, with the starter at intervals of 30 seconds, with the fuel supply shut off.
2. Start and run the engine under no-load condition for 5 to 10 minutes.

⚠ IMPORTANT! If the engine is fitted with a wet exhaust system and the exhaust is situated below the water line the above has to be performed twice a week (if the exhaust is situated above the water line, once a week is enough).

Troubleshooting

A number of symptoms and possible causes for engine disturbances are described in the table below. If faults or hitches arise that you cannot solve alone, you must always get in touch with your Volvo Penta dealer.

NOTE! Dust and foreign particles are the most common cause of excessive wear of parts. When disassembling a component, take measures to prevent dust and foreign particles from entering it.

⚠ WARNING! Read the safety directions for maintenance and service in the chapter “Safety information” before starting any work.

⚠ IMPORTANT! Handle parts carefully. Only use original Volvo Penta spare parts.

Symptoms and possible causes	
Starter motor does not rotate when cranking	1,2,3,4,5,6
Starter motor rotates slowly when cranking	1,2,3,22,48,49
Engine does not start	,8,9,10,11,12,13,14,15,20,21,23,24,28,50,58
Engine is difficult to start	8,9,10,11,12,13,14,15,20,21,23,24,28,50,51
Engine starts but stops again	8,9,10,11,12,13,14,15,20,21,23,24,28,50,51 52,53
Engine does not reach correct operating speed	8,9,10,11,12,13,14,15,18,19,20,21,22, 23,24,25,26,27,28,33,36,53,58
Engine runs unevenly	8,9,10,11,12,13,14,15,16,17,23,24,28,29 51,58
Engine knocks	21,29,52
Engine vibrates	9,17,23,33,34
Engine can not be stopped	2,3,4,6,54
High fuel consumption	13,15,17,19,20,21,25,26,28,30,33
Black or Dark gray exhaust smoke	13,15,17,18,19,20,21,28,30
Blue or white exhaust smoke	17,19,20,21,22,30,33,43,44,51,59
High lubrication oil consumption	22,32,33,34,44
Lubrication oil pressure too low	22,31,35,45,46
Coolant temperature too high	26,38,39,40,41,42,43,55
Coolant temperature too low	43
No charge or poor charge	2,3,47,56,57

- | | | |
|--|--|---|
| 1. Defective starter | 21. Improper fuel oil | 42. Defective cooling water pump |
| 2. Flat batteries | 22. Improper lubrication oil | 43. Defective/wrong thermostat |
| 3. Poor contact/broken cables | 23. Air in fuel system | 44. Too high lubrication oil level |
| 4. Main switch turned off | 24. Water/contamination in fuel | 45. Defective lubrication oil pump |
| 5. Control lever not in neutral/control position not activated | 25. Boat abnormally loaded | 46. Defective relief valve |
| 6. A fuse/circuit breaker has blown/tripped | 26. Fouled hull/propeller | 47. Alternator drive belt slips |
| 7. Lack of fuel | 27. Engine speed control wrongly adjusted | 48. Clutch is engaged |
| 8. Blocked fuel filter | 28. Insufficient air supply | 49. Defective bearings or abnormal cylinder friction |
| 9. Defective fuel filter | 29. Too high coolant temperature | 50. Fuel supply pump strainer blocked |
| 10. Blocked fuel pipes | 30. Too low coolant temperature | 51. Very cold engine and lubrication oil |
| 11. Defective fuel pipes | 31. Too low lubrication oil level | 52. Heavy initial load |
| 12. Blocked fuel supply pump | 32. Lubrication oil leakage | 53. Propeller/propeller shaft blocked |
| 13. Defective fuel supply pump | 33. Worn cylinder liners and/or piston rings | 54. Engine consume lubrication oil or combustible gas |
| 14. Blocked fuel injection pump | 34. Worn valve stem seals | 55. Cylinder liner have scalings or such that reduce cooling effect |
| 15. Defective fuel injection pump | 35. Blocked lubrication oil filter | 56. Alternator/Rectifier broken |
| 16. Blocked fuel injection nozzles | 36. Defective/wrong propeller | 57. Faulty governor |
| 17. Defective fuel injection nozzles | 37. Faulty engine mounting | 58. Broken piston |
| 18. Incorrect valve clearance | 38. Too low coolant level | |
| 19. Incorrect fuel injection timing | 39. Air in fresh water system | |
| 20. Low compression pressure | 40. Blocked sea water inlet/pipe/filter | |
| | 41. Circulation pump drive belt slips | |

Technical Data

D34A MS

General

Number of cylinders	12	
Displacement	33,93 liters (2071 in ³)	
Nominal idling speed	not available	
Low idling speed	625 ±25 rpm	
High idling speed	2006 rpm [rating 1]	2150 rpm [rating 2]
Valve clearance*	0,4 mm (0,016") [inlet]	0,5 mm (0,020") [outlet]
Compression pressure at starter motor speed (120 rpm)	2,45 MPa (356 psi)	
Dry Weight*, engine with heat exchanger, without reverse gear or clutch, approx.	3166 kg (6981 lbs)	

*excl. engine oil & coolant

Exhaust temperatures: **634 kW Rating 1**

1222 r/min.	347°C/(657°F)
1540r/min.	403°C/(757°F)
1763 r/min.	409°C/(768°F)
1940 r/min.	423°C/(793°F)

Exhaust temperatures: **701 kW Rating 2**

1260 r/min.	390°C/(734°F)
1587 r/min.	450°C/(842°F)
1817 r/min.	470°C/(878°F)
2000 r/min.	480°C/(896°F)

* Applies to cold engine.

Lubricating system

Oil capacity, approx.

	Including oil filters
No engine inclination	140 liters (37,0 US gals)
volume difference min. –max.	28 liters (7,4 US gals)
Oil pressure, hot engine:	
at operating speed	0,50-0,64 MPa (71-93 psi)
at idling speed	min.0,20-0,30 MPa (29-43 psi)

Cooling system

Freshwater system capacity including heat exchanger, approx.	100 liters (26 US gals)
--	-------------------------

Electrical system

System voltage	24V
----------------------	-----

AC generator:

voltage/max. amperage	24V/35A
output, approx.	840W

Battery electrolyte density at +25°C (77°F):

fully charged battery	1,28 g/cm ³ = 0,0462 lb/in ³ (1,24 g/cm ³ = 0,0448 lb/in ³)*
battery recharged at	1,24 g/cm ³ = 0,0448 lb/in ³ (1,20 g/cm ³ = 0,0434 lb/in ³)*

* **Note.** Applies to batteries with tropical acid.

D34A MT

General

Number of cylinders	12	
Displacement	33,93 liters (2071 in ³)	
Nominal idling speed	not available	
Low idling speed	625 ±25 rpm	
High idling speed	2006 rpm [rating 1]	2150 rpm [rating 2]
Valve clearance*	0,4 mm (0,016") [inlet]	0,5 mm (0,020") [outlet]
Compression pressure at starter motor speed (120 rpm)	2,45 MPa (356 psi)	
Dry Weight*, engine with heat exchanger, without reverse gear or clutch, approx.	3300 kg (7277 lbs)	

*excl. engine oil & coolant

Exhaust temperatures:

701 kW Rating 1

1222 r/min.	327°C/(621°F)
1540 r/min.	406°C/(763°F)
1763 r/min.	416°C/(781°F)
1940 r/min.	427°C/(801°F)

Exhaust temperatures:

776 kW Rating 2

1260 r/min.	340°C/(644°F)
1587 r/min.	415°C/(779°F)
1817 r/min.	430°C/(806°F)
2000 r/min.	440°C/(824°F)

* Applies to cold or warm engine (stopped).

Lubricating system

Oil capacity, approx.

including oil filters

No engine inclination	140 liters (37,0 US gals)
volume difference min. –max.	28 liters (7,4 US gals)

Oil pressure, hot engine:

at operating speed	0,50-0,64 MPa (71-93 psi)
at idling speed	min.0,20-0,30 MPa (29-43 psi)

Cooling system

Freshwater system capacity

including heat exchanger, approx.	142 liters (37,5 US gals)
--	---------------------------

Electrical system

System voltage	24V
----------------------	-----

AC generator:

voltage/max. amperage	24V/35A
output, approx.	840W

Battery electrolyte density at +25°C (77°F):

fully charged battery	1,28 g/cm ³ = 0,0462 lb/in ³ (1,24 g/cm ³ = 0,0448 lb/in ³)*
battery recharged at	1,24 g/cm ³ = 0,0448 lb/in ³ (1,20 g/cm ³ = 0,0434 lb/in ³)*

* **Note.** Applies to batteries with tropical acid.

Fuel specification

Fuel must comply with national and international standards at the least, e.g.:

JIS KK 2204.	Type1, Type2, Type3
ASTM, D975	No.1-D, No.2-D
BS2869	Class-A1, Class-A2
DIN51601	Diesel-Fuel
ISO8217	DMX-Class

Note! It is necessary to use a fuel that has a pour point suitable for ambient temperature during the operation of the engine. Consult the supplier to select the right type.

Property	Use limit
Flash point.....	As stipulated by regulation
First distillation point	170°C (338°F) or more
90% distillation point	330 to 380°C (626 to 716°F)
Pour point.....	6°C (10.8°F) below ambient temperature
Cloud point	Below ambient temperature
Carbon residue (10% residue oil)	0.4 weight % or lower
Cetan number	45 or more
Cetan index (new)	45 or more
Kinematic viscosity	2.0 mm ² /S or more [30°C (86°F)]
.....	8.0 mm ² /S or lower [50°C (122°F)]
.....	10.5 mm ² /S or lower [40°C (104°F)]
.....	16.0 mm ² /S or lower [30°C (86°F)]
Sulfur content	0.2 weight % or lower
Water and sediment	0.1 volume % or lower
Ash	0.03 weight % or lower
Copper plate corrosion (100°C)[212°F], 3h	No. 3 or lower
Specific gravity (15°C/4°C [59°F/39°F]	0.83 to 0.87
Coking test	Not carbonized 100% at 250°C (482°F)
Aromatics content	38 weight % or lower
Particulate contaminant.....	5.0 mg/liter or lower
Asphaltene	0.1 weight % or lower

Lubrication oil specification

Recommended types of engine oil

Use lubrication oil that meets Class CF standard (recommended engine oil). Class CE and CF-4 engine oils are designed for diesel fuel with a sulfur content of less than 0,5% and less than 0,2%, respectively. Since the sulfur content of most Class-A diesel fuel exceeds 0,5%, do not use class CE or CF-4 engine oil when using class-A diesel fuel

⚠ Important! Use of improper or inferior oil can cause excessive wear of bearings and moving parts, thus shortening the engine life. It can also result in sticking of piston rings and seizing of pistons in the cylinders, thus causing major damage.

Selection of oil viscosity

Use the following chart to select appropriate oil viscosity according to the ambient temperature. Recommended oil viscosity is SAE 15W-40 for all seasons.

⚠ Important! Excessively high oil viscosity causes power loss and higher oil temperature, while excessively low oil viscosity results in inadequate lubrication and leakage of combustion gas with increased wear and reduced output as a result.

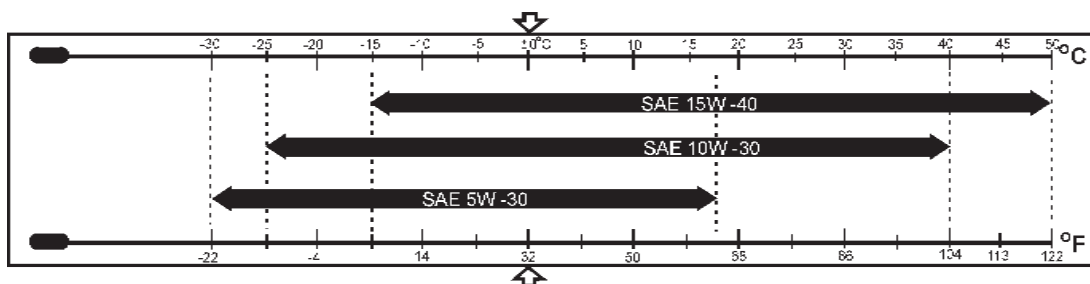

Coolant specification

Always use Volvo Penta Coolant in the freshwater cooling circuit. Volvo Penta Coolant acts both as anti-freeze agent and provides corrosion protection for the metal parts of the cooling system. Future claims might be rejected should Coolant 90 not have been used.

 **Important!** Mixing other types of concentrated coolant with Volvo Penta Coolant, may decrease corrosion protection and may damage the engine or block the cooling system.

Water

Always use clean water that complies with the requirements in ASTM D4985 X1.1. If these requirements are not complied with, corrosion may occur, which would result in impaired cooling performance.

Total fixed particle content	< 340 ppm
Total hardness	< 9,5 °dH
Chloride	< 40 ppm
Sulphate	< 100 ppm
pH value	< 5,5 – 9
Silica	< 20 mg SiO ₂ /l
Iron	< 0.10 ppm
Manganese	< 0.05 ppm
Conductivity	< 500 iS/cm
Organic content, CODMn	<15 mg kMnO ₄ /L

Mixing ratio

The mixture of Volvo Penta Coolant and water should contain 40-55% Volvo Penta Coolant. If the coolant contains less than 40% Volvo Penta Coolant, the cooling galleries in the engine or radiator may be blocked by contamination. If the coolant contains more than 60% Volvo Penta Coolant the cooling ability of the coolant mixture is impaired, this may cause the engine to overheat. Too high concentration of Volvo Penta Coolant also impairs the frost protection.

 **Important!** The mixture of Volvo Penta Coolant and water may never contain less than 40% Volvo Penta Coolant.

Tightening Torque Table

Important Bolts and Nuts D34 MS

Description	Thread		Torque			Notes
	Diam.xPitch (M-Thread)	Nm	kpm	lbf.ft		
Cylinder head bolts	20 x 2,5	392	40	289	(a) (b) (c)	
Rocker shaft brackets	12 x 1,75	49	5	36		
Rocker arm lock nuts	12 x 1,25	64	6,5	47		
Valve bridge lock nuts	10 x 1,25	55	5,6	40		
Camshaft gear	30 x 1,5	294	30	216	Left-hand thread	
Camshaft thrust plate	12 x 1,25	59	6	43		
Main bearing caps	24 x 3	588	60	434	(a)(d)	
Main bearing cap side bolts	16 x 1,5	147	15	108	(a)(d)	
Piston cooling nozzles	12 x 1,75	34	3,5	25	(f)	
Timing gear case	12 x 1,75	98	10	72		
Rear plate	12 x 1,25	98	10	72		
Oil pan	10 x 1,5	39	4	29		
Front mounting bracket	20 x 1,5	392	40	290		
Rear mounting bracket	18 x 2,5	245	25	181		
Connecting rod bearing caps	18 x 1,5	343	35	253	(a) (f)	
Flywheel	22 x 1,5	539	55	398	(a)	
Crankshaft pulley and damper	22 x 1,5	539	55	398		
Idler shaft	12 x 1,75	54	5,5	40		
Idler gears	10 x 1,25	39	4	29		
Oil pump drive gear shaft	27 x 1,5	294	30	216		
Oil pump cover	10 x 1,25	26,3-39,7	2,7-4,1	18-32		
Fresh water pump impeller	22 x 1,5	196	20	145		
Fresh water pump pulley	24 x 1,5	245	25	181		

(a) Wet , apply lubrication oil to the threads of the nut and bolt.

(b) 2-step tightening method,

(c) Tighten cylinder head bolts according to the angle method, tighten short bolts to 118 Nm (12 kpm) [86,8 lbf.ft], then tighten 60° more.

(d) Tighten bolts according to the following sequence:

1. Tighten the cap bolts to specified torque
2. Tighten side bolts on the right side of the engine
3. Tighten side bolts on the left side of the engine

(e) Extremely important to use torque wrench in tightening the piston cooling nozzles. Failure to do so may result in excessive tightening torque, which may cause valve malfunctions that could lead to seizing of pistons due to insufficient lubrication.

(f) Tighten connecting rod caps according to the angle method, tighten to 147 Nm [15 kpm][108,5 lbf.ft], then tighten 45° more.

Important Bolts and Nuts D34 MS

Description	Thread		Torque			Notes
	Diam.xPitch (M-Thread)	Nm	kpm	lbf.ft		
Fuel rack control lever	8 x 1,25	25	2,5	18	(b)	
Injection pump drive gear	30 x 1,5	294	30	216		
Injection pump laminate plate	12 x 1,75	83-93	8,5-9,5	61-69		
Injection pump coupling shaft	14 x 1,5	83-93	8,5-9,5	61-69		
Gland (injection nozzle holder)	12 x 1,25	98	10	72		
Injection nozzle set screw	16 x 1	39-49	4-5	29-36		
Injection nozzle tip retaining nuts	19 x 1	59-78	6-8	43-58		
Exhaust manifolds	10 x 1,5	59-69	6-7	43-51		
Turbocharger compressor wheel (nut)	11 x 1,0	–	–	–	TD10,13(g)(h)(i)	
Turbocharger V-clamp	–	7,8-9,8	0,8-1,0	5,8-7,2	TD10,13 (h)	

(a) Wet , apply lubrication oil to the threads of the nut and bolt.

(b) 2-step tightening method

(c) Tighten cylinder head bolts according to the angle method, tighten to 294 Nm [30 kpm; 217 lbf.ft], then tighten 60° more.

(d) Tighten bolts according to the following sequence:

1. Tighten the cap bolts to specified torque
2. Tighten side bolts on the right side of the engine
3. Tighten side bolts on the left side of the engine

(e) Extremely important to use torque wrench in tightening the piston cooling nozzles. Failure to do so may result in excessive tightening torque, which may cause valve malfunctions that could lead to seizing of pistons due to insufficient lubrication.

(f) Tighten connecting rod caps according to the angle method, tighten to 245 Nm [25 kpm; 181 lbf.ft], then tighten 60° more.

(g) Left-handed thread.

(h) Apply Moly Disulfide to thread.

(i) Tighten the lock nut to 9,8 Nm [1 kpm][7,2 lbf.ft] then loosen it completely. Retighten to 9,8 Nm [1 kpm][7,2 lbf.ft], then tighten 80±3° more.

Important Bolts and Nuts D34 MT

Description	Thread		Torque		Notes
	Diam.xPitch (M-Thread)	Nm	kpm	lbf.ft	
Cylinder head bolts	20 x 2,5	392	40	289	(a) (b) (c)
Rocker shaft brackets	12 x 1,75	49	5	36	
Rocker arm lock nuts	12 x 1,25	64	6,5	47	
Valve bridge lock nuts	10 x 1,25	55	5,6	40	
Camshaft gear	30 x 1,5	294	30	216	Left-hand thread
Camshaft thrust plate	12 x 1,25	59	6	43	
Main bearing caps	24 x 3	588	60	434	(a)(d)
Main bearing cap side bolts	16 x 1,5	147	15	108	(a)(d)
Piston cooling nozzles	12 x 1,75	34	3,5	25	(e)
Timing gear case	12 x 1,75	98	10	72	
Rear plate	12 x 1,25	98	10	72	
Oil pan	10 x 1,5	39	4	29	
Front mounting bracket	20 x 1,5	392	40	290	
Rear mounting bracket	18 x 2,5	245	25	181	
Connecting rod bearing caps	18 x 1,5	343	35	253	(a) (f)
Flywheel	22 x 1,5	539	55	398	(a)
Crankshaft pulley and damper	22 x 1,5	539	55	398	
Idler shaft	12 x 1,75	54	5,5	40	
Idler gears	10 x 1,25	39	4	29	
Oil pump drive gear shaft	27 x 1,5	294	30	216	
Oil pump cover	10 x 1,25	26,3-39,7	2,7-4,1	18-32	
Fresh water pump impeller	22 x 1,5	196	20	145	
Fresh water pump pulley	24 x 1,5	245	25	181	

(a) Wet , apply lubrication oil to the threads of the nut and bolt.

(b) 2-step tightening method,

(c) Tighten cylinder head bolts according to the angle method, tighten short bolts to 118 Nm (12 kpm) [86,8 lbf.ft], then tighten 60° more.

(d) Tighten bolts according to the following sequence:

1. Tighten the cap bolts to specified torque
2. Tighten side bolts on the right side of the engine
3. Tighten side bolts on the left side of the engine

(e) Extremely important to use torque wrench in tightening the piston cooling nozzles. Failure to do so may result in excessive tightening torque, which may cause valve malfunctions that could lead to seizing of pistons due to insufficient lubrication.

(f) Tighten connecting rod caps according to the angle method, tighten to 147 Nm [15 kpm][108,5 lbf.ft], then tighten 45° more.

Important Bolts and Nuts D34 MT

Description	Thread		Torque		Notes
	Diam.xPitch (M-Thread)	Nm	kpm	lbf.ft	
Sea water pump cam (screw)	10 x 1,25	14-16	1,4-1,6	10-12	
Sea water pump casing	8 x 1,25	7-8	0,7-0,8	5-6	
Sea water pump cover	8 x 1,25	7-8	0,7-0,8	5-6	
Sea water pump pulley (nut)	33 x 3,5	196	20	145	
Fuel rack control lever	8 x 1,25	25	2,5	18	(b)
Injection pump drive gear	30 x 1,5	294	30	216	
Injection pump laminate plate	12 x 1,75	83-93	8,5-9,5	61-69	
Injection pump coupling shaft	14 x 1,5	83-93	8,5-9,5	61-69	
Gland (injection nozzle holder)	12 x 1,25	98	10	72	
Injection nozzle set screw	16 x 1	39-49	4-5	29-36	
Injection nozzle tip retaining nuts	19 x 1	59-78	6-8	43-58	
Exhaust manifolds	10 x 1,5	59-69	6-7	43-51	
Turbocharger compressor wheel (nut)	11 x 1,0	–	–	–	TD10,13(g)(h)(i)
Turbocharger V-clamp	–	7,8-9,8	0,8-1,0	5,8-7,2	TD10,13 (h)

(a) Wet , apply lubrication oil to the threads of the nut and bolt.

(b) 2-step tightening method

(c) Tighten cylinder head bolts according to the angle method, tighten to 294 Nm [30 kpm; 217 lbf.ft], then tighten 60° more.

(d) Tighten bolts according to the following sequence:

1. Tighten the cap bolts to specified torque
2. Tighten side bolts on the right side of the engine
3. Tighten side bolts on the left side of the engine

(e) Extremely important to use torque wrench in tightening the piston cooling nozzles. Failure to do so may result in excessive tightening torque, which may cause valve malfunctions that could lead to seizing of pistons due to insufficient lubrication.

(f) Tighten connecting rod caps according to the angle method, tighten to 245 Nm [25 kpm; 181 lbf.ft], then tighten 60° more.

(g) Left-handed thread.

(h) Apply Moly Disulfide to thread.

(i) Tighten the lock nut to 9,8 Nm [1 kpm][7,2 lbf.ft] then loosen it completely. Retighten to 9,8 Nm [1 kpm][7,2 lbf.ft], then tighten 80±3° more.

Standard Bolts and Nuts

Fine threads

Thread diameter x pitch mm [in.]	Strength classification					
	7T			10.9		
	Nm	kpm	lbf.ft	Nm	kpm	lbf.ft
M10 x 1,25 [0.39 x 0.049]	33	3,4	25	60	6,1	44
M12 x 1,25 [0.47 x 0.049]	60	6,1	44	108	11,0	80
M14 x 1,5 [0.55 x 0.059]	97	9,9	72	176	17,9	129
M16 x 1,5 [0.63 x 0.059]	145	14,8	107	262	26,7	193
M18 x 1,5 [0.71 x 0.059]	210	21,4	155	378	38,5	278
M20 x 1,5 [0.79 x 0.059]	291	29,7	215	524	53,4	386
M22 x 1,5 [0.87 x 0.059]	385	39,3	284	694	70,8	512
M24 x 1,5 [0.94 x 0.059]	487	49,7	359	878	89,5	647
M27 x 3 [1.06 x 0.12]	738	75,3	544	1328	135,5	980

Coarse threads

M8 x 1,25 [0.31 x 0.049]	17	1,7	12	30	3,1	22
M10 x 1,5 [0.39 x 0.059]	32	3,3	24	58	5,9	43
M12 x 1,75 [0.47 x 0.069]	57	5,8	42	102	10,4	75
M14 x 2 [0.55 x 0.079]	93	9,5	69	167	17,0	123
M16 x 2 [0.63 x 0.079]	139	14,2	103	251	25,6	185
M18 x 2,5 [0.71 x 0.098]	194	19,8	143	350	35,7	258
M20 x 2,5 [0.79 x 0.098]	272	27,7	200	489	49,9	361
M22 x 2,5 [0.87 x 0.098]	363	37,0	268	653	66,6	482
M24 x 3 [0.94 x 0.12]	468	47,7	345	843	86,0	622
M27 x 3 [1.06 x 0.12]	686	70,0	506	1236	126,0	911

Standard eyebolts

Thread diameter x pitch mm [in.]	Strength classification		
	4T		
	Nm	kpm	lbf.ft
M8 x 1,25 [0.31 x 0.049]	8±1	0,8±0,1	5,8±0,72
M10 x 1,25 [0.39 x 0.049]	15±2	1,5±0,2	10,8±1,45
M12 x 1,25 [0.47 x 0.049]	25±3	2,5±0,3	18,1±2,17
M14 x 1,5 [0,55 x 0.059]	34±4	3,5±0,4	25,3±2,89
M16 x 1,5 [0.63 x 0.059]	44±5	4,5±0,5	32,5±3,62
M18 x 1,5 [0.71 x 0.059]	74±5	7,5±0,5	54,2±3,62
M20 x 1,5 [0.79 x 0.059]	98±10	10,0±1,0	72,3±7,23
M24 x 1,5 [0.94 x 0.059]	147±15	15,0±1,5	108,5±10,8
M27 x 3 [1.06 x 0.12]	226±20	23,0±2,0	166,3±14,5

(Dry)

Standard union nuts

Cap nut size diameter x pitch	Strength classification			Nominal diameter
	Nm	kpm	lbf.ft	
mm [in.]				
M14 x 1,5 [0.55 x 0.059]	39	4	29	63
M16 x 1,5 [0.63 x 0.059]	49	5	36	80
M20 x 1,5 [0.79 x 0.059]	78	8	58	100
M22 x 1,5 [0.87 x 0.059]	98	10	72	120
M27 x 1,5 [1.06 x 0.059]	157	16	116	150
M30 x 1,5 [1.18 x 0.059]	196	20	145	180
M30 x 1,5 [1.18 x 0.059]	196	20	145	200
M33 x 1,5 [1.30 x 0.059]	245	25	181	220
M36 x 1,5 [1.42 x 0.059]	294	30	217	254

(Dry)

High pressure fuel injection pipes

Cap nut size diameter x pitch	Strength classification		
	Nm	kpm	lbf.ft
mm [in.]			
M12 x 1,5 [0.49 x 0.059]	39±5	4±0,5	29±3,6
M14 x 1,5 [0.55 x 0.059]	49±5	5±0,5	36±3,6
M18 x 1,5 [0.71 x 0.059]	59±1	6±1,0	43±7,2

(Dry)

Identification numbers D34A

Type plates with identification numbers can be found on the engine and the transmission or generator. This information must always be used as a reference when ordering service and spare parts.

Engine
 Product designation
 Serial and basic engine number
 Product number

Certification, IMO
 Decal, part No.
 Approval No.

Transmission / Generator
 Product designation
 Serial number
 Product number

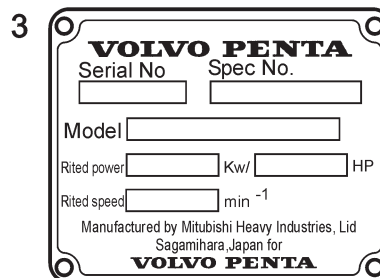
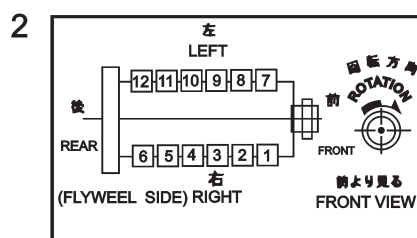
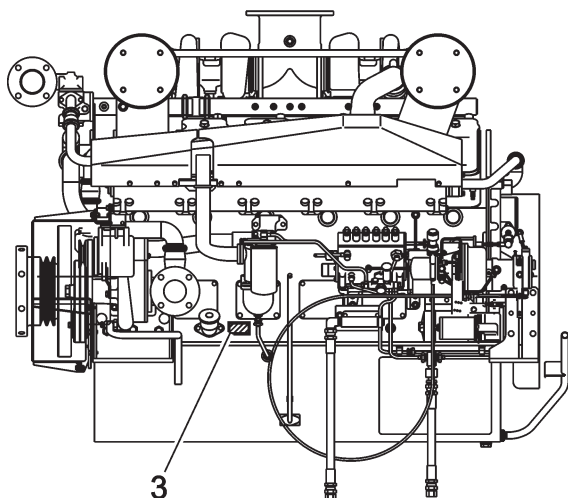
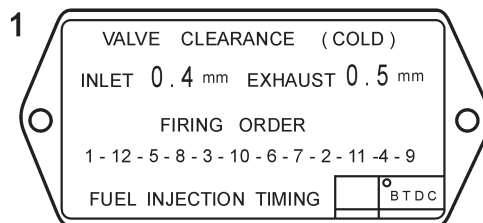
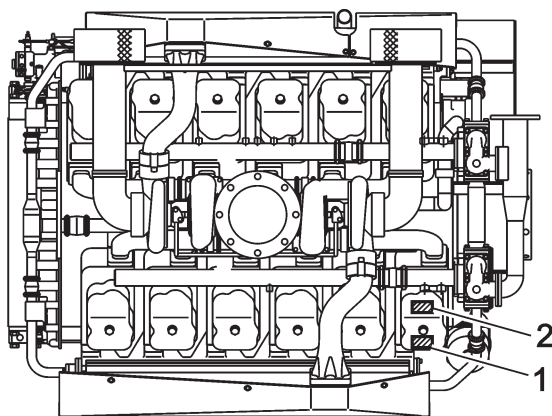

Sea trial data

Date

Name

Vessel

Engine no.

Miscellaneous

Engine speed rpm

Vessel speed knots

Ambient/eng. room temp. °C

Sea water temp. °C

Eng. cooling water out Left bank °C

Eng. cooling water out Right bank °C

Cooler in °C

Cooler out °C

Eng. cooling water in °C

Lubrication oil pressure Bar

Lubrication oil temp. °C

Air intake Left bank °C

Air intake Right bank °C

Charge air temp. Left bank °C

Charge air temp. Right bank °C

Charge air press. Left bank Bar

Charge air press. Right bank Bar

Exhaust gas temp. Left bank °C

Exhaust gas temp. Right bank °C

Exhaust gas temp. common °C

Fuel temp. engine in °C

Fuel press. Bar

Type and brand of lubrication oil

Type and brand of coolant

Mixture of coolant

Type of fuel during normal operation

All values to be measured at full load. All values to be measured with approved instrumentation.
If in doubt mount your own equipment.

Notes

A series of horizontal dotted lines for writing notes.

Notes

A series of horizontal dotted lines for writing notes.

