

INSTALLATION INSTRUCTIONS

D2-55

(ENG) **Installation Instructions**
Connection kit MS25S
Kit number 3583436

(SPA) **Instrucciones de montaje**
Kit de conexión MS25S
Kit número 3583436

(GER) **Einbauanleitung**
Anschlusssatz MS25S
Satznummer 3583436

(ITA) **Istruzioni di montaggio**
Kit di connessione MS25S
Kit numero 3583436

(FRE) **Instructions de montage**
Kit de raccordement MS25S
Numéro de kit 3583436

(SWE) **Monteringsanvisning**
Anslutningsatts MS25S
Satsnummer 3583436

VOLVO
PENTA

IMPORTANT!

This batch with its accompanying instructions is produced for Volvo Penta's service workshops, boat-builders, machine manufacturers and other authorized workshops which have personnel with qualified professional training.

The installation instructions are only produced for professional use and are not intended for non-professional use. Volvo Penta will not assume any liability whatsoever for damage incurred, either damage to materials or personal injury, which may result if the installation instructions are not followed or if the work is carried out by non-professional personnel.

WICHTIG!

Dieser Satz mit vorliegender Einbauanleitung ist für Volvo Penta Kundendienst-werkstätten, Werften, Maschinenbauer und für andere ermächtigte Werkstätten mit beruflich geschultem Personal vorgesehen.

Die Einbauanleitung ist nur für den berufsmäßigen Gebrauch vorgesehen und nicht für unprofessionelle Anwendung gedacht. Volvo Penta übernimmt nicht die geringste Haftung für irgendwelchen Schäden an Personen oder Sachen, die als Folge einer Nichtbefolgung der Einbauanleitung oder wegen Ausführung der darin beschriebenen Arbeiten durch nicht beruflich geschulte Personen entstehen.

IMPORTANT!

Ce kit, avec instructions de montage, est destiné aux ateliers de service Volvo Penta, aux constructeurs de bateaux et autres ateliers de construction agréés avec un personnel qualifié.

Les instructions de montage sont exclusivement conçues pour une utilisation professionnelle. Volvo Penta se dégage de toute responsabilité pour d'éventuels endommagements, corporels ou matériels, résultant du non respect des instructions ou d'un travail effectué par un personnel non compétent.

IMPORTANTE!

El presente juego con las instrucciones de montaje se destina a los talleres de servicio Volvo Penta, constructores de embarcaciones y máquinas y a otros talleres autorizados que cuentan con personal capacitado.

Las instrucciones de montaje están destinadas únicamente para uso profesional, por lo que Volvo Penta no aceptará responsabilidad alguna por cualquier daño, tanto personal como material, resultado de no haber seguido las instrucciones de montaje o de haber sido efectuado el trabajo por personal que no está debidamente capacitado.

IMPORTANTE!

Questo kit e le relative istruzioni di montaggio sono stati realizzati per le officine di servizio Volvo Penta, i cantieri, i fabbricanti di macchine e tutte le altre officine autorizzate il cui personale ha ricevuto un addestramento qualificato e specializzato.

Le istruzioni di montaggio sono state redatte esclusivamente per uso professionale e non sono adatte all'uso non professionale. La Volvo Penta non si assume alcuna responsabilità per eventuali danni alle cose o alle persone, derivanti da trascuratezza nel seguire le istruzioni di montaggio oppure dall'esecuzione dei lavori da parte di personale non qualificato.

VIKTIGT!

Denna sats med föreliggande monteringsanvisning är framtagen för Volvo Pentas serviceverkstäder, båtbyggare, maskintillverkare och övriga auktoriserade verkstäder som har personal med kvalificerad fackutbildning.

Monteringsanvisningen är enbart framtagen för yrkesbruk och är inte avsedd för icke yrkesmässig användning. Volvo Penta påtager sig inget som helst ansvar för eventuella skador, såväl materiella som personskador, som kan bli följden om monteringsanvisningen ej följs, eller om arbetet utförs av icke yrkeskunnig personal.

VIGTIGT!

Dette sæt med tilhørende monteringsvejledning er blevet udviklet for Volvo Pentas serviceværksteder, bådbyggere, maskinproducenter og andre autoriserede værksteder, som har medarbejdere med kvalificeret, faglig uddannelse.

Monteringsvejledningen er udelukkende beregnet til professionel anvendelse og ikke til hobby- eller fritidsbrug. Volvo Penta påtager sig intet som helst ansvar for eventuelle skader på såvel materiel som personer, som kan være en følge af at monteringsvejledningens anvisninger ikke blev overholdt, eller hvis arbejdet blev udført af ikke-professionelt personale.

TÄRKEÄÄ!

Tämä sarja ja asennusohje on tarkoitettu Volvo Pentan huoltokorjaamoille, veneenrakentajille, konevalmistajille ja muille valtuutetuille korjaamoille, joiden henkilökunta on saanut pätevän ammattikoulutuksen.

Asennusohje on tarkoitettu ainoastaan ammattikäyttöön. Volvo Penta ei vastaa mahdollisista materiaali- tai henkilövahingoista, joita asennusohjeen laiminlyöminen tai ammattitaidottoman henkilökunnan suorittama asennustyö voi aiheuttaa.

BELANGRIJK!

Deze set met de bijgevoegde montage-aanwijzing is ontwikkeld voor de werkplaatsen van Volvo Penta, botenbouwers, machinefabrikanten en overige bevoegde werkplaatsen, die personeel hebben met een gekwalificeerde vakopleiding.

De montage-aanwijzing is alleen ontwikkeld voor professioneel gebruik en is niet bedoeld voor niet-professioneel gebruik. Volvo Penta neemt geen enkele verantwoordelijkheid op zich voor eventuele schade, zowel materiële schade als persoonlijk letsel, die het gevolg kan zijn als de montage-aanwijzing niet wordt gevolgd, of als het werk wordt uitgevoerd door niet-vakkundig personeel.

IMPORTANTE!

Este jogo, juntamente com as respectivas instruções de montagem, foi concebido para as oficinas de serviço da Volvo Penta, construtores navais, construtores de máquinas e outras oficinas autorizadas, com pessoal devidamente formado.

As instruções de montagem foram concebidas unicamente para utilização profissional e não se destinam a utilização não profissional. A Volvo Penta não se responsabiliza por quaisquer danos eventuais, tanto materiais como pessoais, que possam resultar no caso de as instruções de montagem não serem seguidas, ou se os trabalhos forem executados por pessoal não profissional.

ΠΡΟΣΟΧΗ!

Το περιεχόμενο αυτού του πακέτου μαζί με τις οδηγίες συναρμολόγησης που το ακολουθούν είναι ειδικά επιλεγμένο για συνεργεία σέρβις της Volvo Penta, ναυπηγεία, κατασκευαστές μηχανών και για λοιπά εξουσιοδοτημένα συνεργεία που διαθέτουν εξειδικευμένο προσωπικό.

Οι οδηγίες συναρμολόγησης προορίζονται μόνο για επαγγελματική χρήση και δεν αποσκοπούν για χρήση από μη επαγγελματίες. Η Volvo Penta δεν αναλαμβάνει απολύτως καμία ευθύνη για πιθανές ζημιές, τόσο υλικές όσο και προσωπικές, που μπορούν να προκληθούν επειδή δεν ακολουθούνται οι οδηγίες συναρμολόγησης ή επειδή η εργασία εκτελείται από μη εξειδικευμένο προσωπικό.

ENG

This kit contains:

Designation	Qty	Pos. in fig.
Hose	1	1
Bracket 1x11x40x3	1	2
Bracket A1-11x72	1	3
Screw M8x16	2	4
Nut M8	3	5
Hose clamp	2	6
Hose clamp type B-27	2	7
Hose clamp type B-44	2	8
Screw 7/16UNCx38	4	9
Washer 12x22x2	4	10
Rubber pad	2	11
Spring washer	2	12
Screw M16x1,5x35	2	13
Washer 17x30	4	14
Screw M10x25	4	15
Washer 10,5x22x2	4	16
Bracket	1	17
Hose 70mm	1	18
Screw M12x110	1	19
Locknut M12	1	20
Washer	2	21
Socket cap screw	2	22
Screw M8x25	8	23
Screw M8x30	2	24
Washer 4x16x1,5	10	25
Washer	1	26
Flanged screw M8x30	1	27
Control connection kit	1	-
Control kit	1	-
Assembly instruction	1	-

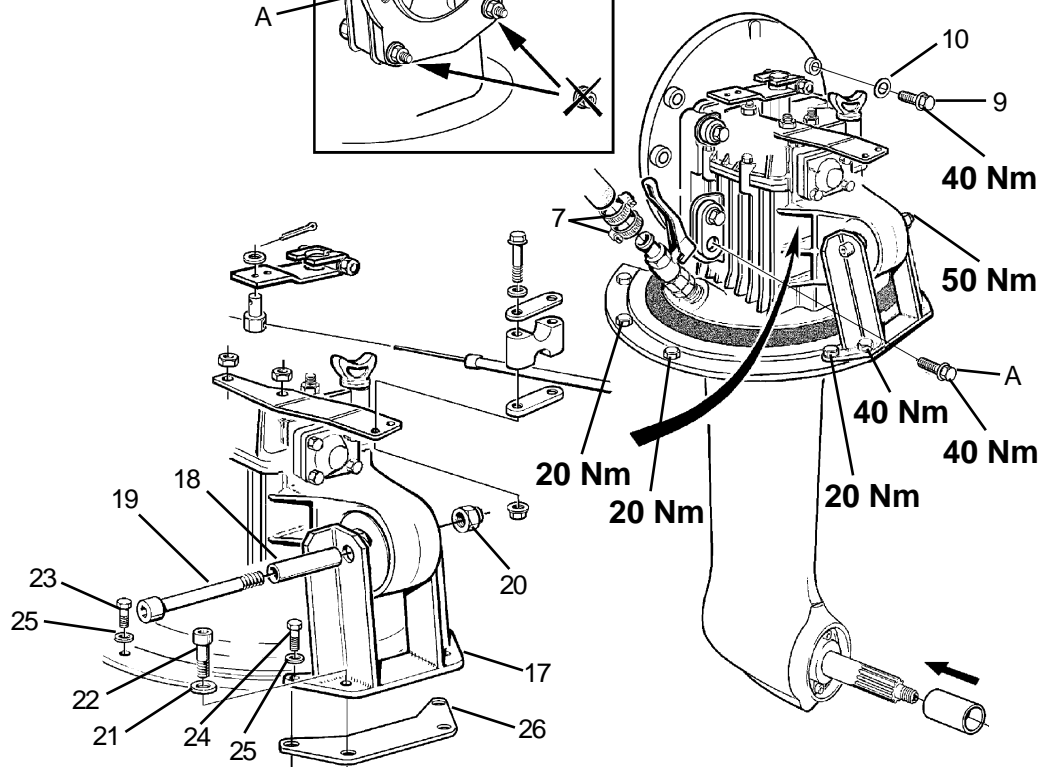
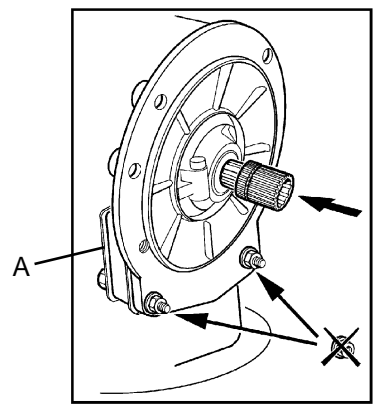
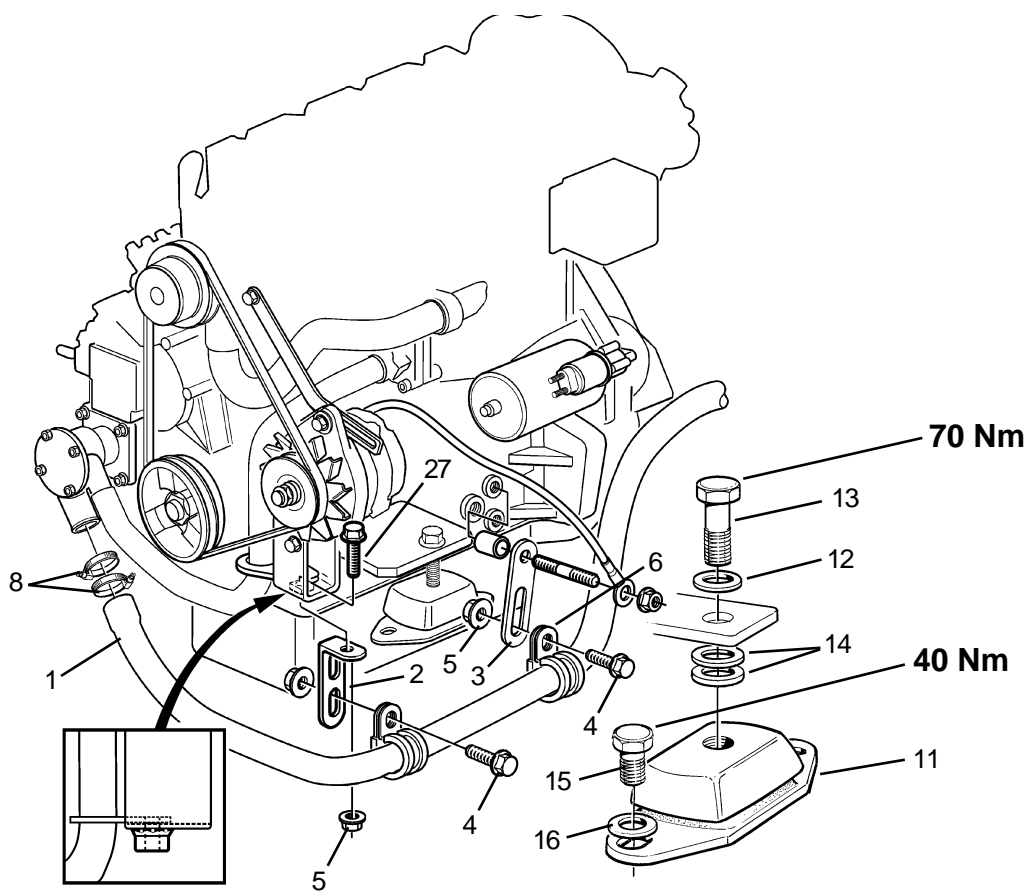



Inhalt des Einbausatzes:

Benennung	Menge	Pos. im Bild
Schlauch	1	1
Konsole 1x11x40x3	1	2
Konsole A1-11x72	1	3
Schraube M8x16	2	4
Mutter M8	3	5
Schlauchschele	2	6
Schlauchschele Typ B-27	2	7
Schlauchschele Typ B-44	2	8
Schraube 7/16UNCx38	4	9
Scheibe 12x22x2	4	10
Gummiblock	2	11
Federscheibe	2	12
Schraube M16x1,5x35	2	13
Scheibe 17x30	4	14
Schraube M10x25	4	15
Scheibe 10,5x22x2	4	16
Konsole	1	17
Schlauch 70 mm	1	18
Schraube M12x110	1	19
Sicherungsmutter M12	1	20
Scheibe	2	21
Innensechskantschraube	2	22
Schraube M8x25	8	23
Schraube M8x30	2	24
Scheibe 4x16x1,5	10	25
Scheibe	1	26
Bundschraube M8x30	1	27
Bedienung Anschlusssatz	1	-
Bedienungssatz	1	-
Einbauanleitung	1	-

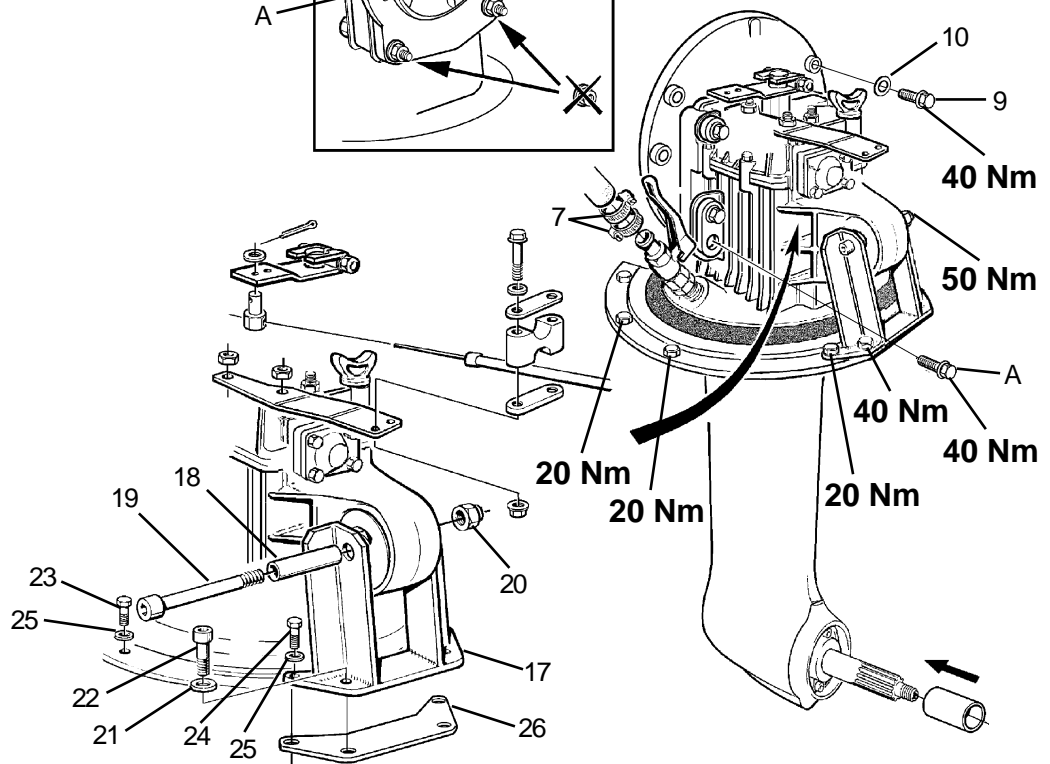
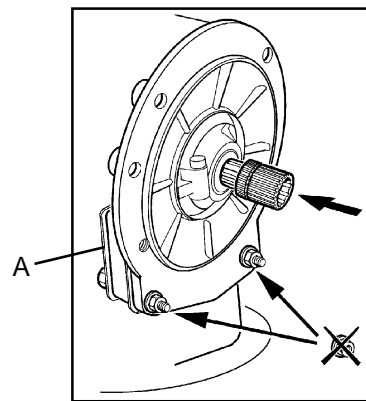
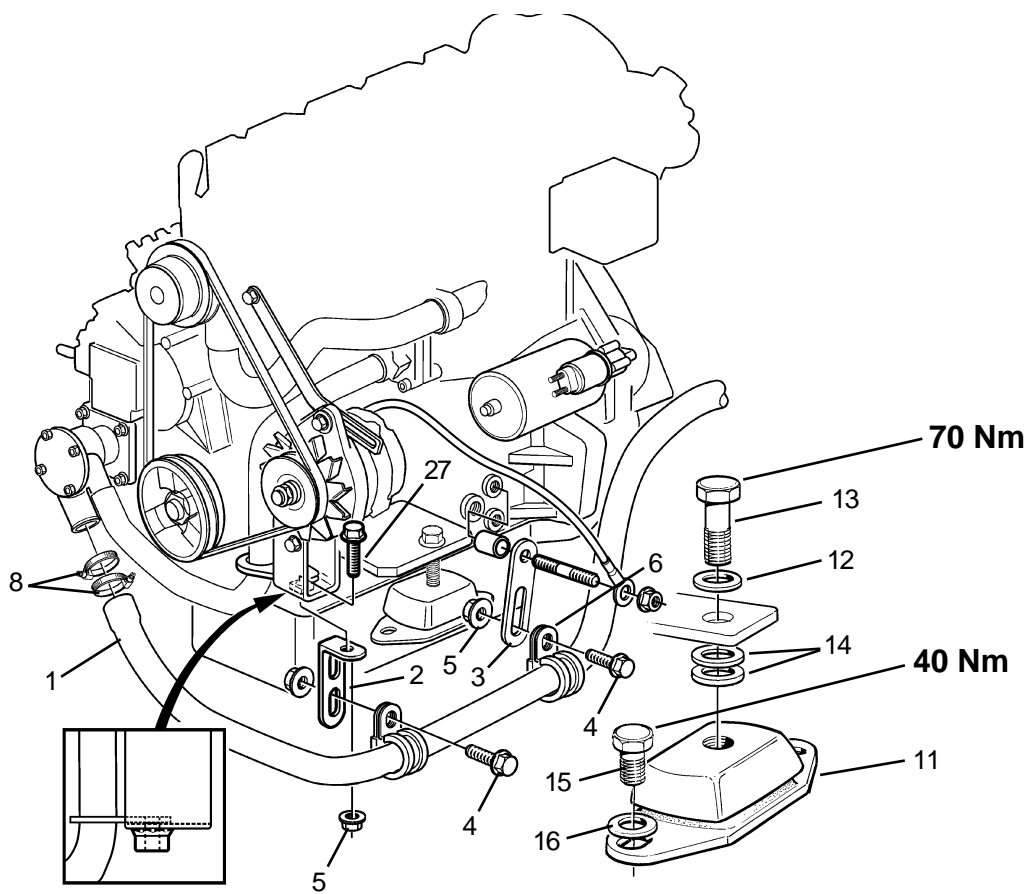

FRE

Ce kit contient :

Désignation	Nombre	Rep. dans fig.
Durit	1	1
Console 1x11x40x3	1	2
Console A1-11x72	1	3
Vis M8x16	2	4
Écrou M8	3	5
Collier de serrage	2	6
Collier de serrage type B-27	2	7
Collier de serrage type B-44	2	8
Vis 7/16UNCx38	4	9
Rondelle 12x22x2	4	10
Silentbloc	2	11
Rondelle élastique	2	12
Vis M16x1,5x35	2	13
Rondelle 17x30	4	14
Vis M10x25	4	15
Rondelle 10,5x22x2	4	16
Console	1	17
Durit70mm	1	18
Vis M12x110	1	19
Écrou de blocage M12	1	20
Rondelle	2	21
Vis six pans	2	22
Vis M8x25	8	23
Vis M8x30	2	24
Rondelle 4x16x1,5	10	25
Rondelle	1	26
Vis à bride M8x30	1	27
Kit de connexion de commande	1	-
Kit de commande	1	-
Instructions de montage	1	-

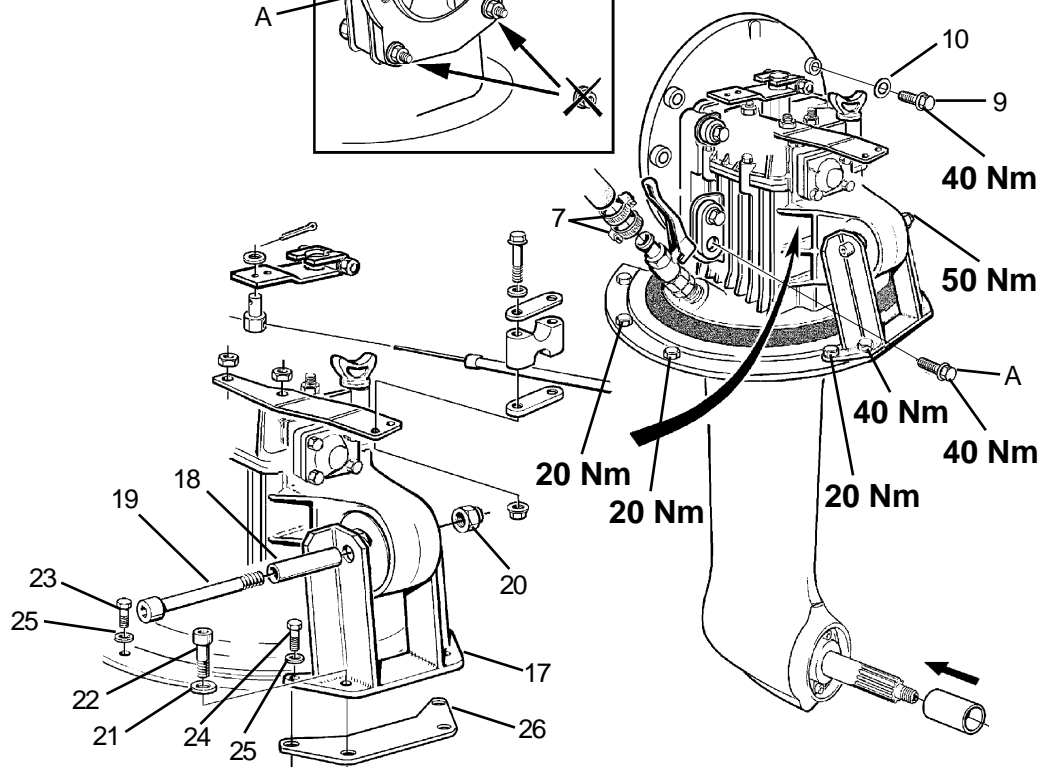
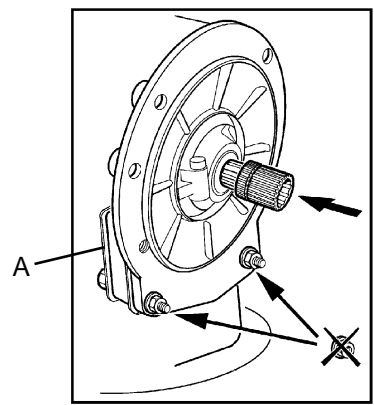
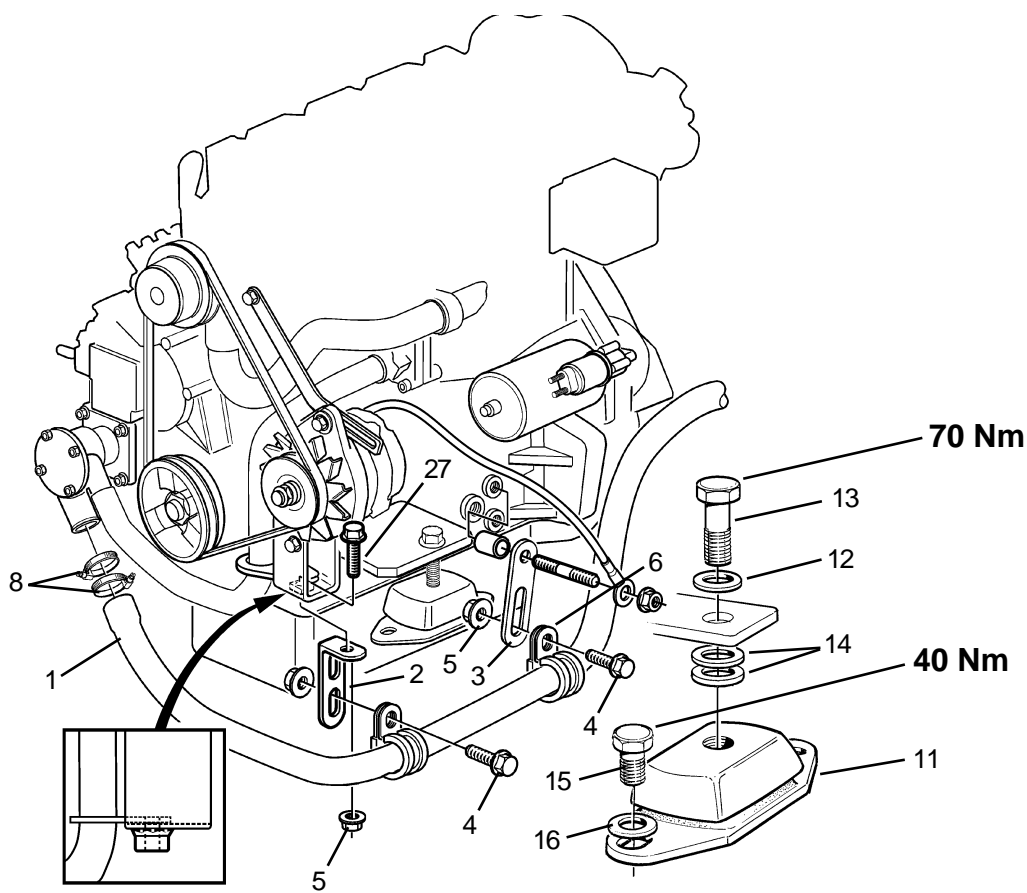



Este kit contiene:

Denominación	Cant.	Pos. en fig.
Manguera	1	1
Consola 1x11x40x3	1	2
Consola A1-11x72	1	3
Tornillo M8x16	2	4
Tuerca M8	3	5
Abrazadera de manguera	2	6
Abrazadera de manguera tipo B-27	2	7
Abrazadera de manguera tipo B-44	2	8
Tornillo 7/16UNCx38	4	9
Arandela 12x22x2	4	10
Taco de goma	2	11
Arandela elástica	2	12
Tornillo M16x1,5x35	2	13
Arandela 17x30	4	14
Tornillo M10x25	4	15
Arandela 10,5x22x2	4	16
Consola	1	17
Manguera 70 mm	1	18
Tornillo M12x110	1	19
Contratuerca M12	1	20
Arandela	2	21
Tornillo de hexágono embutido	2	22
Tornillo M8x25	8	23
Tornillo M8x30	2	24
Arandela 4x16x1,5	10	25
Arandela	1	26
Tornillo embreadado M8x30	1	27
Mando, kit de conexiones	1	-
Kit de mando	1	-
Instrucciones de montaje	1	-

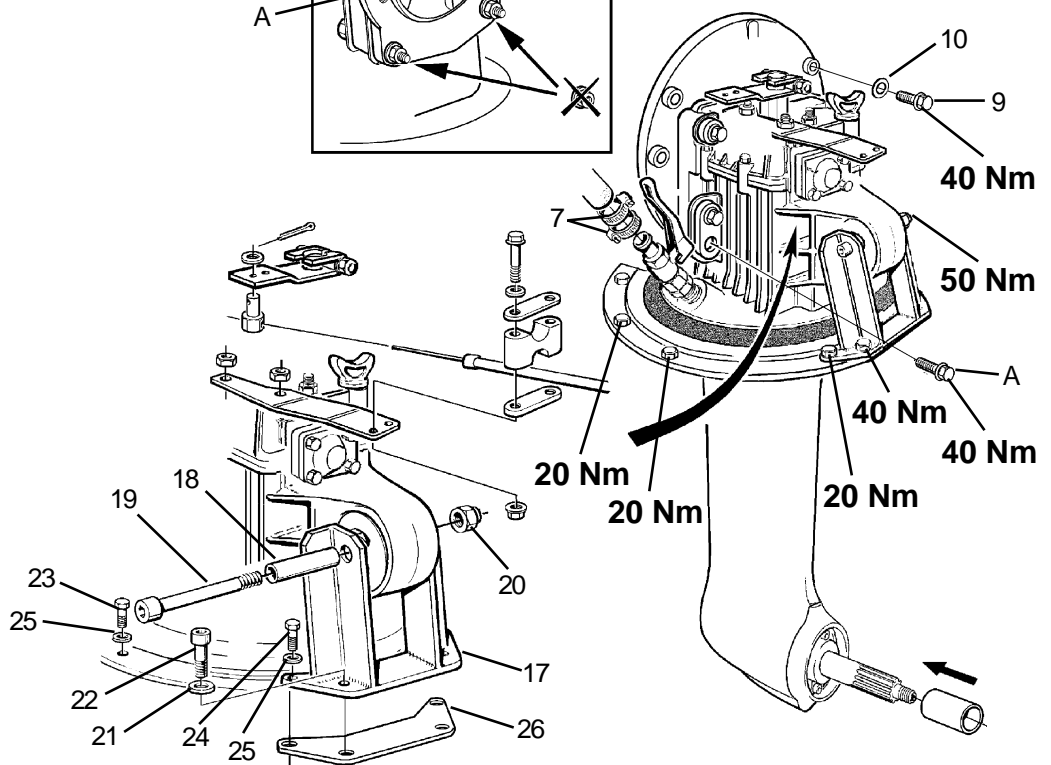
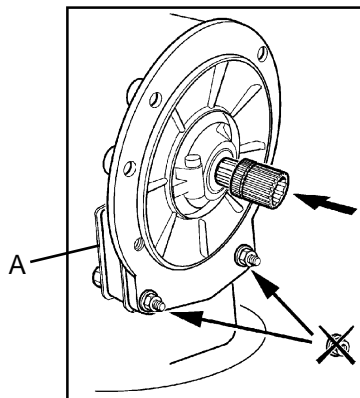
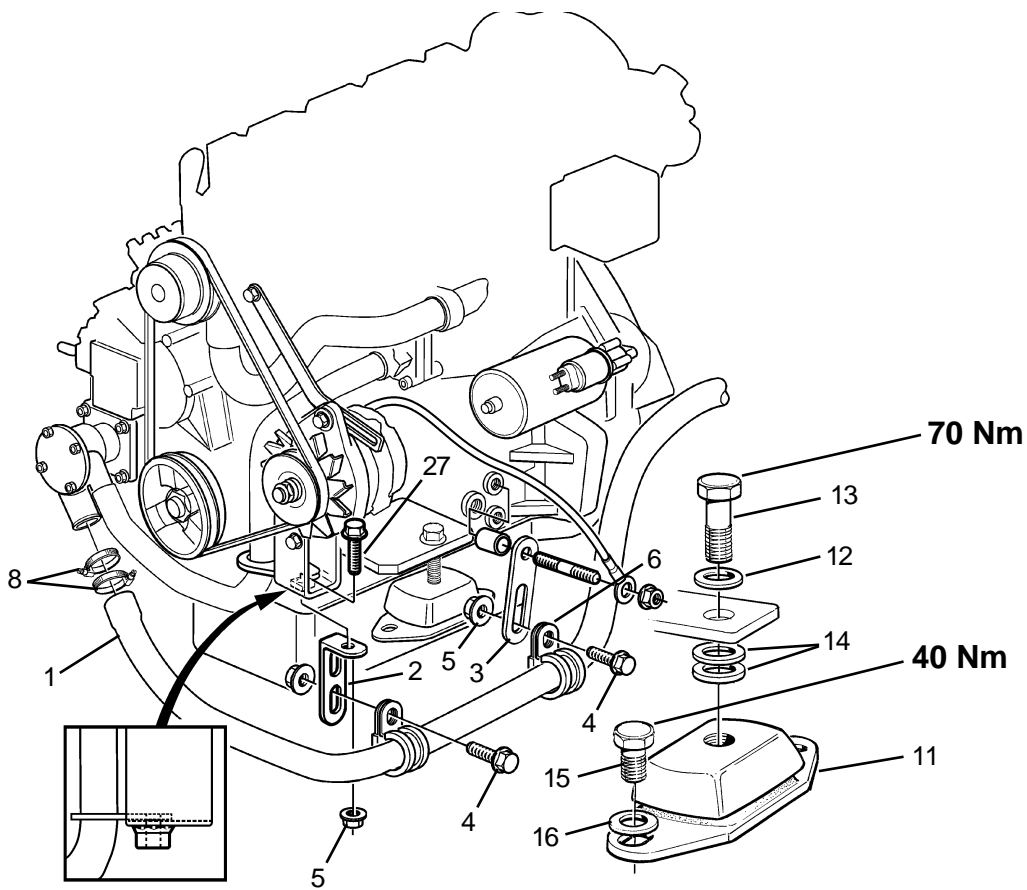

Il presente kit contiene:

Denominazione	Quantità	Pos. in fig.
Flessibile	1	1
Staffa 1x11x40x3	1	2
Staffa A1-11x72	1	3
Vite M8x16	2	4
Dado M8	3	5
Fascetta stringitubo	2	6
Fascetta tipo B-27	2	7
Fascetta tipo B-44	2	8
Vite 7/16UNCx38	4	9
Rondella 12x22x2	4	10
Tampone in gomma	2	11
Rondella elastica	2	12
Vite M16x1,5x35	2	13
Rondella 17x30	4	14
Vite M10x25	4	15
Rondella 10,5x22x2	4	16
Staffa	1	17
Flessibile 70mm	1	18
Vite M12x110	1	19
Dado di bloccaggio M12	1	20
Rondella	2	21
Vite a brugola	2	22
Vite M8x25	8	23
Vite M8x30	2	24
Rondella 4x16x1,5	10	25
Rondella	1	26
Vite flangiata M8x30	1	27
Kit di connessione comando	1	-
Kit comando	1	-
Istruzioni di montaggio	1	-

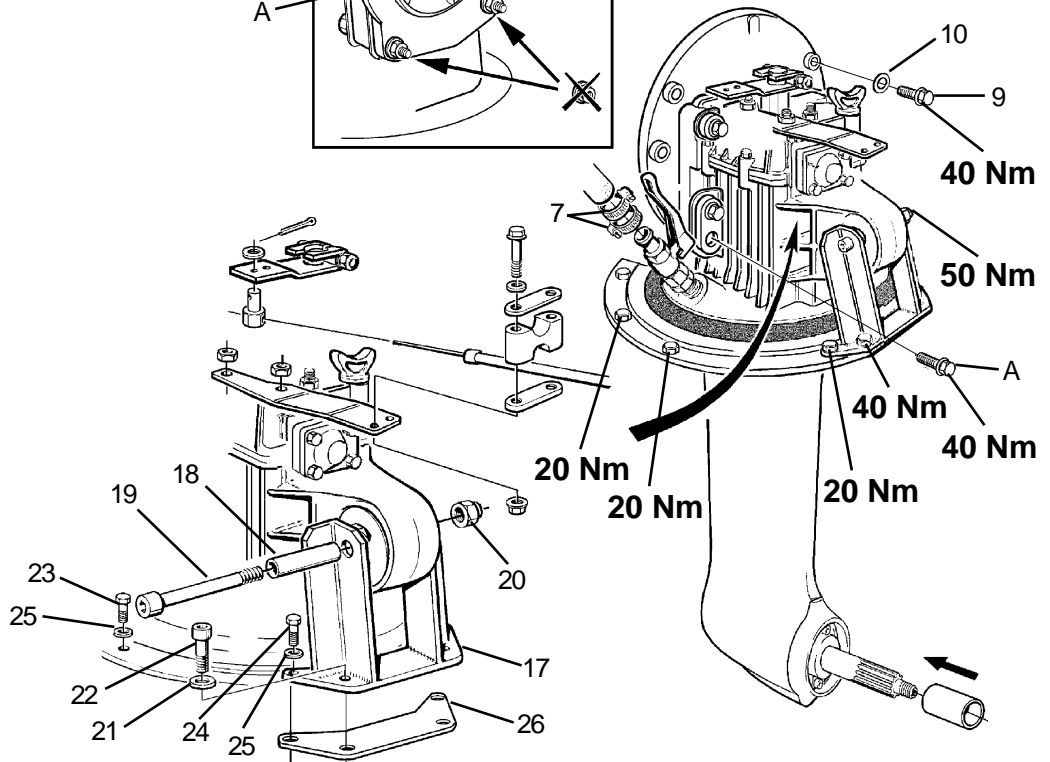
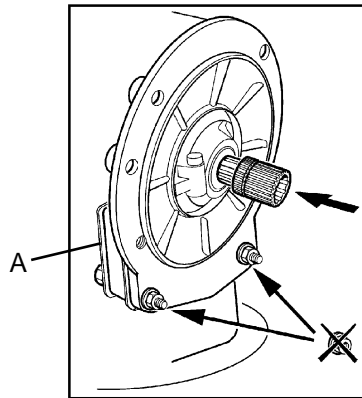
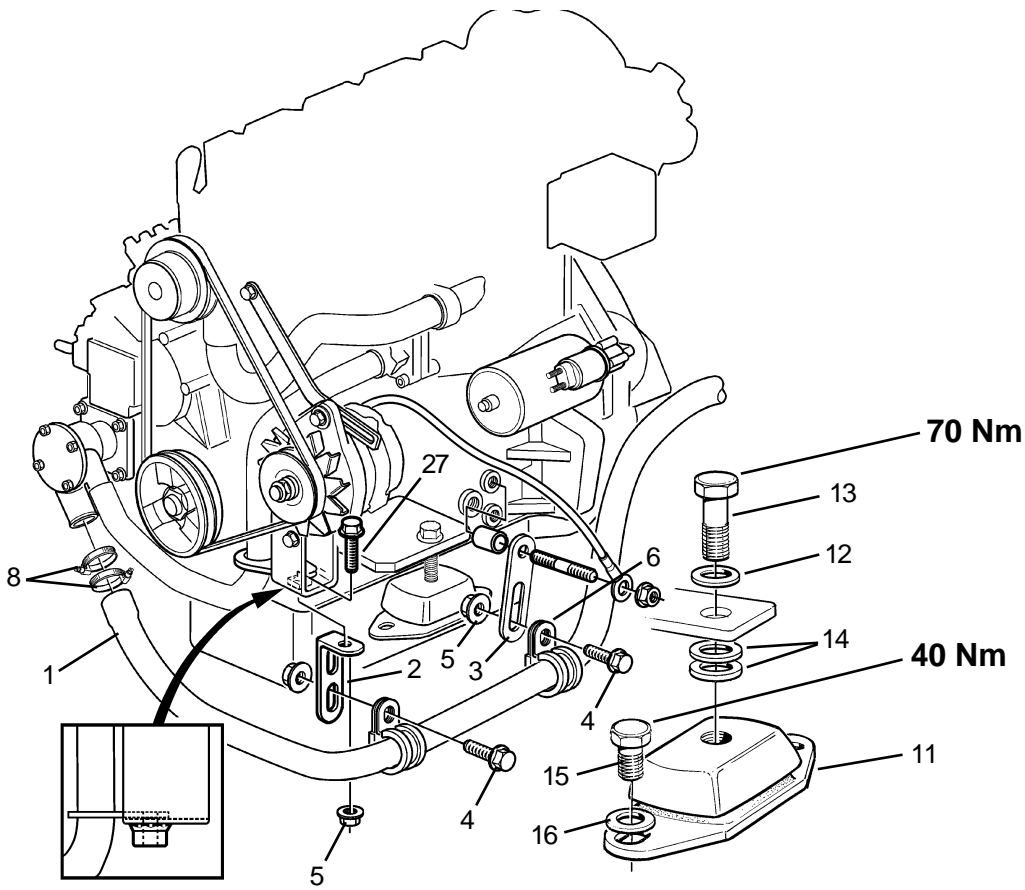



Denna sats innehåller:

Benämning	Antal	Pos. i fig.
Slang	1	1
Konsol 1x11x40x3	1	2
Konsol A1-11x72	1	3
Skruv M8x16	2	4
Mutter M8	3	5
Slangklamma	2	6
Slangklämma typ B-27	2	7
Slangklämma typ B-44	2	8
Skruv 7/16UNCx38	4	9
Bricka 12x22x2	4	10
Gummikudde	2	11
Fjädrandebricka	2	12
Skruv M16x1,5x35	2	13
Bricka 17x30	4	14
Skruv M10x25	4	15
Bricka 10,5x22x2	4	16
Konsol	1	17
Slang 70mm	1	18
Skruv M12x110	1	19
Låsmutter M12	1	20
Bricka	2	21
Insexsskruv	2	22
Skruv M8x25	8	23
Skruv M8x30	2	24
Bricka 4x16x1,5	10	25
Bricka	1	26
Flänsskruv M8x30	1	27
Reglage anslutningssats	1	-
Reglagesats	1	-
Monteringsanvisning	1	-

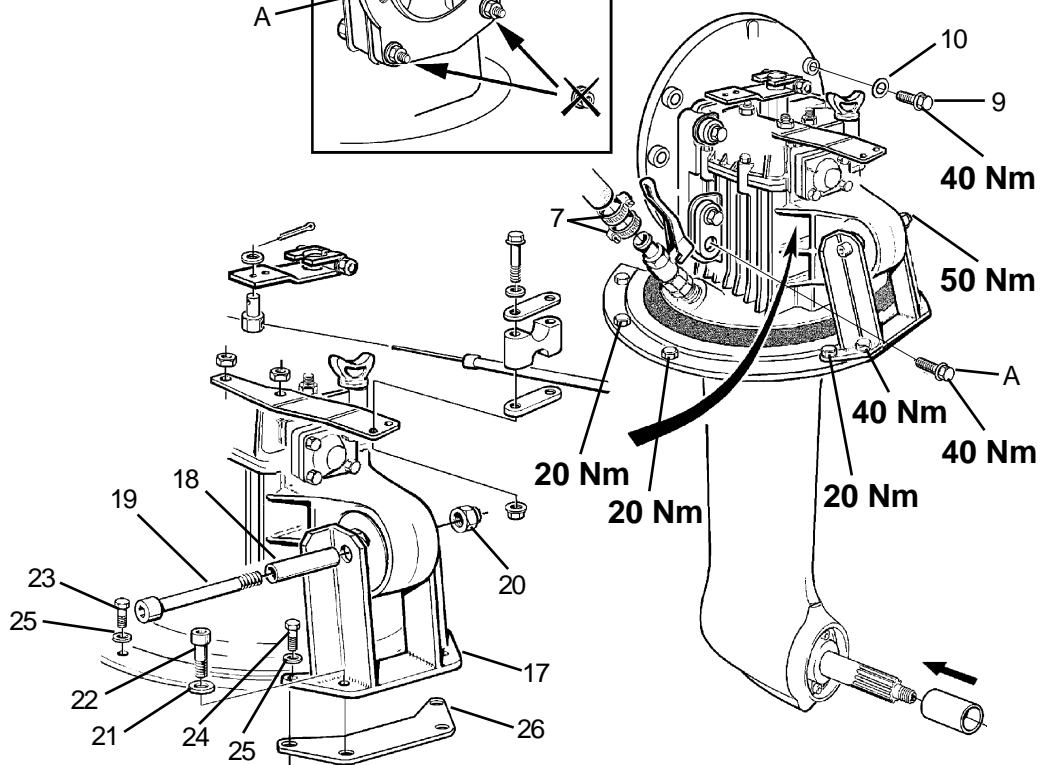
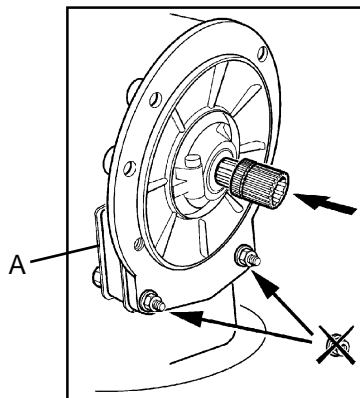
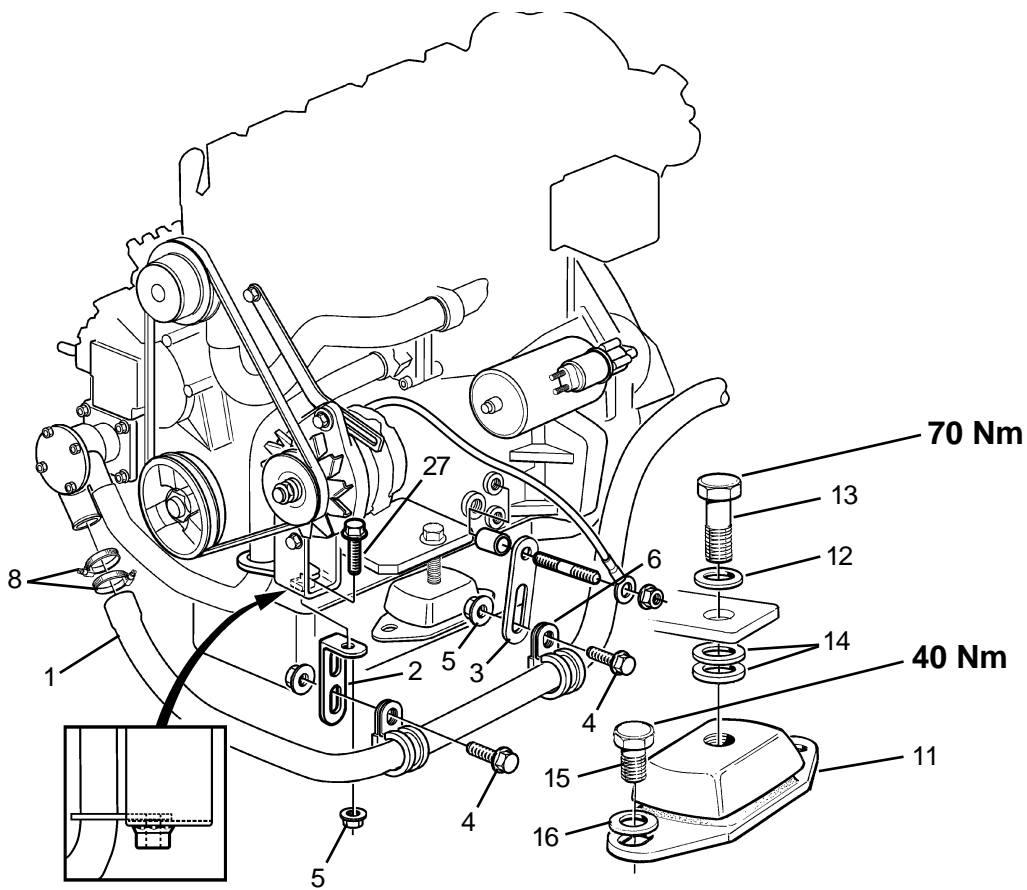

VOLVO
PENTA
AB Volvo Penta
SE-405 08 Göteborg, Sweden

7741489 01-2002 (Tab 2)

Plus d'informations sur : www.dbmoteurs.fr