

INSTRUCTION BOOK

ENG GER FRE SPA ITA SWE

3000 Diesel series MD11, MD17/MS2, 120S

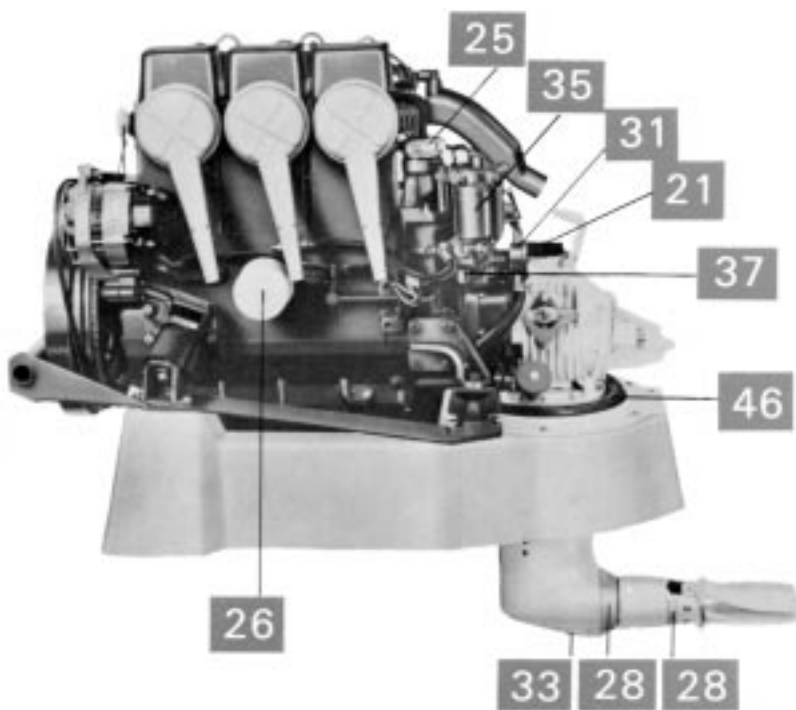
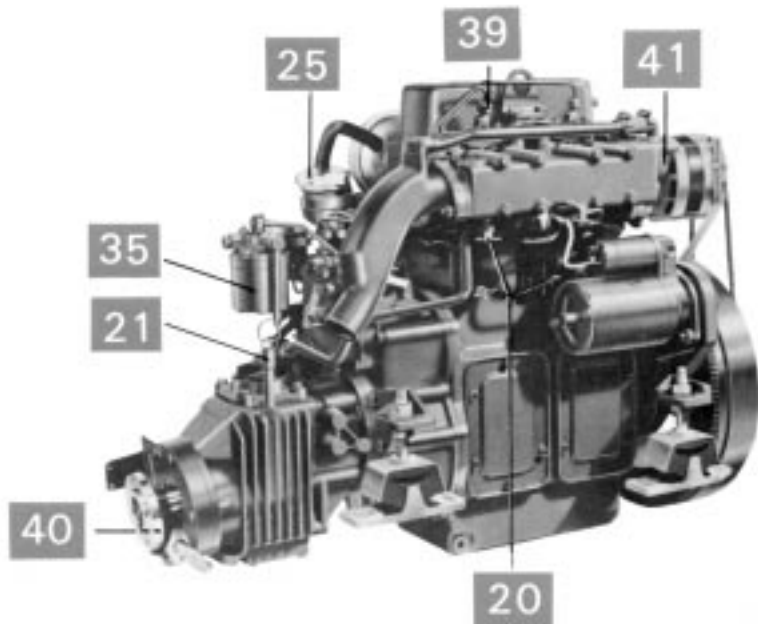
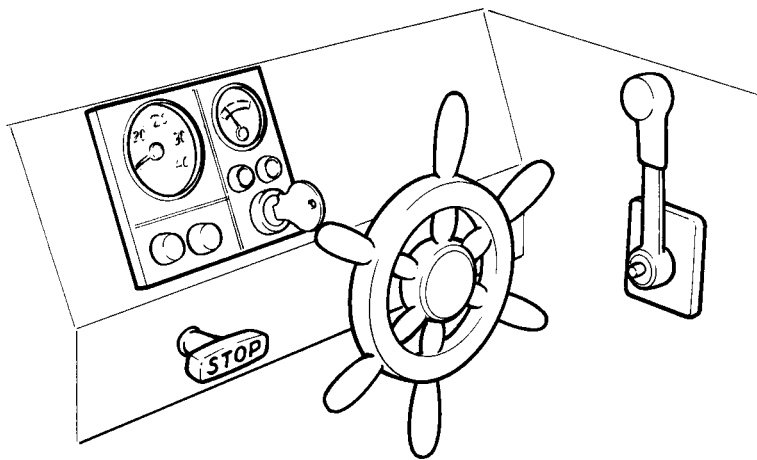

FOREWORD

A warranty certificate is supplied with each new engine. Included in the warranty certificate is a delivery card which is to be completed by the dealer or boat seller and forwarded to Volvo Penta.

A new engine must be run-in with due care during the first 20 hours of operation

Change the engine oil and oil filter after the engine has been run for 20 hours.

VORWORT

Jedem Motor wird ein Kundendienstheft beigelegt. Das Kundendienstheft hat eine Lieferungskarte, die von der Vertretung oder vom Bootverkäufer ausgefüllt und an Volvo Penta weitergeleitet wird.

Ein neuer Bootsmotor erfordert vorsichtiges Einfahren während der ersten 20 Betriebsstunden.

Nach 20 Betriebsstunden ist der Schmieröl in Motor und Ölfilter zu wechseln.

AVANT-PROPOS

Tous les moteurs sont accompagnés à la livraison d'un carnet d'entretien.

Le carnet d'entretien contient une fiche de livraison, qui doit être transmise à Volvo Penta, après avoir été remplie par le concessionnaire ou par le vendeur du bateau.

Un moteur marin neuf exige un rodage prudent durant les 20 premières heures de service.

L'huile moteur et le filtre à huile doivent être remplacés après 20 heures de service.

INTRODUCCION

Cada motor es suministrado con un librito de servicio.

El librito de servicio incluye una tarjeta de informe, que debe ser llenada por el concesionario, o por el vendedor de la embarcación, para ser enviada a Volvo Penta.

Un motor marino nuevo exige un ablande cuidadoso durante las primeras 20 horas de funcionamiento.

Después de 20 horas de funcionamiento, debe cambiarse el aceite lubricante del motor y el filtro.

PREFAZIONE

Ogni motore è accompagnato da un libretto di garanzia. I termini della garanzia sono specificati nel libretto stesso che vi consigliamo di leggere attentamente. Un motore marino nuovo deve essere rodato con cura durante le prime 20 ore di funzionamento. Sostituire l'olio ed il relativo filtro dopo le prime 20 ore di moto.

FÖRORD

Med varje motor följer ett servicehäfte.

Servicehäftet har leveranskort, som skall ifyllas av återförsäljaren eller båtförsäljaren, och vidarebefordras till Volvo Penta.

En ny motor fordrar en försiktig inkörning under de första 20 driftstimmarna.

Efter 20 timmars driftstid skall motorns smörjolja samt oljefilter bytas.

DIESEL



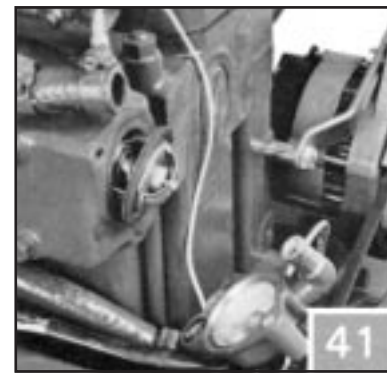
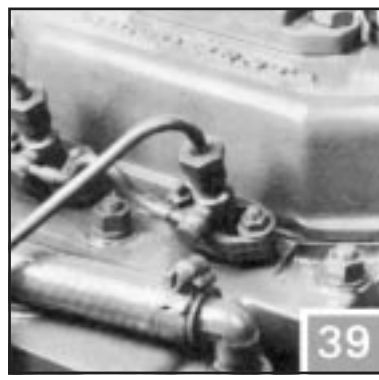
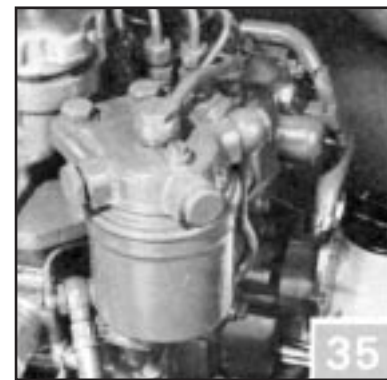
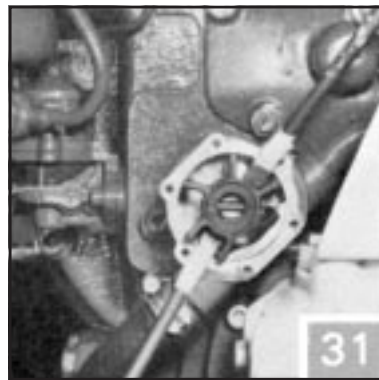
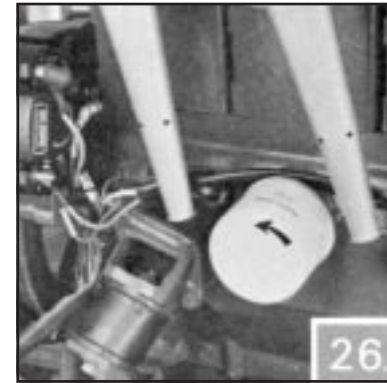
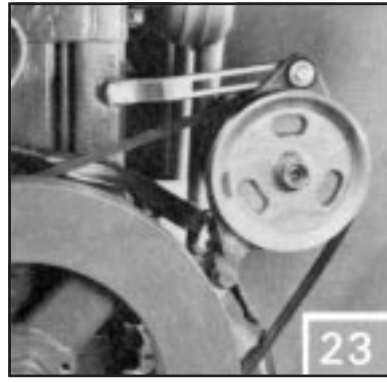
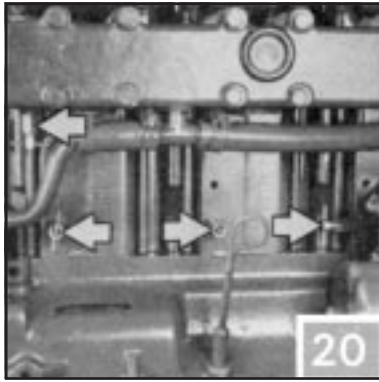

Technical data

Type designation	Motorbezeichnung
Number of cylinders	Zylinderzahl
Prop. shaft output ¹⁾ kW (hp)	Propellerwellenleistung ¹⁾ kW (PS)
Max. operating speed r/min	Größte Betriebsdrehz. r/s (U/min)
Bore, mm	Bohrung, mm
Stroke, mm	Hub, mm
Displacement, dm ³ = litres	Hubraum, dm ³
Idling speed (r/min)	Leerlaufdrehzahl (U/min)
Direction rot, from flywheel	Drehrichtung, Schwungradrichtung
Max. rearwards inclin. underway	Neigung rückwärts max. bei Betrieb
Max. sideways inclin. underway	Neigung seitlich max.
Weight engine incl. rev. gear, kg	Motor einschl. Wendegetriebe kg
Weight engine incl. S-drive 120S kg	Motor einschl. A-Antrieb 120S kg
Fuel	Kraftstoff

VALVES

Clearance, inlet mm (in) hot engine	Einlaß, mm, warmer Motor
outlet, mm (in) hot engine	Auslaß, mm warmer Motor
Decompression, downwards	Dekompression, Senkung

LUBRICATING SYSTEM ENGINE

Oil capacity, lit. engine excl. filter	Ölfüllmenge l. ausschl. Filter
Oil capacity, lit. engine incl. filter	Ölfüllmenge l. einschl. Filter
Oil grade	Ölqualität
Viscosity, above +10°C	Viskosität, über +10°C
below +10°C	unter +10°C
Ratio, MS2 rev. gear with red. gear	Untersetzung, MS2 Wendegetriebe mit Untersetzungsgetriebe
Oil capacity, lit. MS2	Ölfüllmenge, lit. MS2
Oil grade (same as for engine)	Ölqualität (wie im Motor)
Viscosity, above +10°C (50°F)	Viskosität, über+10°C
below +10°C (50°F)	unter +10°C
Ratio, S-drive 120S	Untersetzung, S-Antrieb 120S
Oil capacity, lit. 120S	Ölfüllmenge, lit. 120 S
Oil grade (same as for the engine)	Ölqualität (wie im Motor)
Viscosity (same as for the engine)	Viskosität (wie im Motor)
Thermostat opens at °C (°F)	Thermostat öffnet bei °C (°F)
Thermostat fully open °C (°F)	Thermostat, voll geöffnet bei °C (°F)

ELECTRICAL SYSTEM

Battery voltage, V	Batteriespannung, V
Battery capacity, starter motor max Ah	Batteriekapazität, max. Ah
Starter motor rating, kW	Anlasserleistung, kW
Alternator rating, A (W)	Generatorleistung A (W)
Battery electrolyte spec. grav:	Spez. Gewicht det Batteriefl.:
Charging to be carried out at g/cm ³	Ladung erforderlich bei g/cm ³
Fully charged battery, g/cm ³	Aufgeladene Batterie, g/cm ³

TIGHTENING TORQUES

Cylinder head nuts Nm (kpm) (lbf. ft.)	Zylinderkopf-Mutter Nm (kpm)
Injector yoke nuts Nm (kpm) (lbf. ft.)	Muttern f. Düsenhalterb. Nm (kpm)

- 1) Propeller shaft output according to DIN Leistung B für Dauerbetrieb
- 2) Volvo Penta CD oil, Double grade
- 3) CD oil, Single grade

Technische Daten

Motorbezeichnung	Zylinderzahl
Propellerwellenleistung ¹⁾ kW (PS)	Größte Betriebsdrehz. r/s (U/min)
Bohrung, mm	Hub, mm
Hubraum, dm ³	Leerlaufdrehzahl (U/min)
Drehrichtung, Schwungradrichtung	Neigung rückwärts max. bei Betrieb
Neigung seitlich max.	Motor einschl. Wendegetriebe kg
Motor einschl. A-Antrieb 120S kg	Kraftstoff

VENTILE

Einlaß, mm, warmer Motor	Auslaß, mm warmer Motor
Dekompression, Senkung	

SCHMIERANLAGE MOTOR

Ölfüllmenge l. ausschl. Filter	Ölfüllmenge l. einschl. Filter
Ölqualität	Viskosität, über +10°C
	unter +10°C
Untersetzung, MS2 Wendegetriebe mit Untersetzungsgetriebe	Ölfüllmenge, lit. MS2
Ölqualität (wie im Motor)	Viskosität, über+10°C
	unter +10°C
Untersetzung, S-Antrieb 120S	Ölfüllmenge, lit. 120 S
Ölqualität (wie im Motor)	Ölqualität (wie im Motor)
Viskosität (wie im Motor)	Thermostat öffnet bei °C (°F)
Thermostat, voll geöffnet bei °C (°F)	

ELEKTRISCHE ANLAGE

Batteriespannung, V	Batteriekapazität, max. Ah
Anlasserleistung, kW	Generatorleistung A (W)
Spez. Gewicht det Batteriefl.:	Ladung erforderlich bei g/cm ³
Aufgeladene Batterie, g/cm ³	

ANZUGSMOMENTE

Zylinderkopf-Mutter Nm (kpm)	Muttern f. Düsenhalterb. Nm (kpm)
------------------------------	-----------------------------------

- 1) Propellerwellenleistung gem. DIN Leistung B für Dauerbetrieb
- 2) Volvo Penta CD Öl Double grade
- 3) CD Öl Single grade

Caractéristiques techniques

	MD11 D	MD17D
Désignation du moteur	2	3
Nombre de cylindres	18,4 kW (25 hp)	26,5 kW (36 hp)
Puissance à l'arbre porte-hélice ¹⁾		3000
Régime maxi de marche (tr/mn)		88,9
Alésage, mm		90
Course, mm	1.12	1.68
Cylindrée, dm ³		750-800
Régime de ralenti (tr/mn) env.		
Sens de rotation, vu du côté volant		
Incl. mot. en cours de marche:		15°
Maxi à l'arrière		
Incl. mot., marche:		15°
Maxi dans le sens latéral		
Poids moteur, inverseur compris, kg	221	281
Poids moteur, avec transm. 120S, kg	238	308
Carburant		Autodiesel

SOUPAPES

Jeu culbut., admis., mm, mot. chaud	0.30 (0.012")
Jeu culbut., échap., mm, mot. chaud	0.35 (0.014")
Poussée princip. soupape d'échap. par le dispositif de décharge	0.5

SYSTEME DE GRAISSAGE MOTEUR

Contenance d'huile, lit, sans filtre	2.6	4.4
Contenance d'huile, lit, avec filtre	2.9	4.7
Qualité d'huile		CD
Viscosité, au-dessus de +10°C		SAE 15 W-40 ²⁾
au-dessous de +10°C		SAE 10W ⁶⁾
Démultiplic.: marche AV et AR, inverseur		2.4:1 alt 3.0:1
MS2 avec réducteur		
Contenance d'huile, lit. MS2		0.8
Qualité d'huile (même que moteur)		CD
Viscosité, au-dessus de +10°C		SAE 20/W30 ²⁾
au-dessous de +10°C		SAE 10W ⁶⁾
Démult., transm. bat. à voile 120S		2.20:1
Contenance d'huile, lit. 120S		2.2
Quantité d'huile (même que moteur)		CD
Viscosité (même que moteur)		
Thermostat, début. d'ouvert. à °C (°F)		60 (140)
Thermostat, complètement ouvert à °C (°F)		74 (165)

SYSTEME ELECTRIQUE

Tension de batterie, V		12
Capacité de batterie, standard max Ah	70	90
Démarrateur kW	1,1	1,9
Alternateur A (W)		50 (14 x 50)
Densité d'électrolyte:		
Batterie à charger à g/cm ³		1.230
Batterie pleinement chargée à g/cm ³		1.275-1.285

COUPLES DE SERRAGE

Ecrous de culasse Nm (kpm)	110 (11)
Ecrous d'injecteur Nm (kpm)	20 (2.0)

- 1) Puissance à l'arbre porte-hélice conformément à la norme DIN Leistung B für Dauerbetrieb
- 2) Huile Double grade Volvo Penta CD
- 3) Huile Monograde CD



Caution!
Achtung!
Avertissement!

Datos técnicos

Dati tecnici

Tekniska data

			MD11 D	MD17D
Designación del motor	Designazione motore	Motorbeteckning	2	3
Número de cilindros	Numero cilindri	Cylinderantal, st	2	3
Potencia en el eje de hélice ¹⁾	Potenza all'asse elica ¹⁾	Propelleraxeffect ¹⁾	18,4 kW (25 hp)	26,5 kW (36 hp)
Régimen de servicio máx rpm	Velocità massima (giri/min)	Max. driftsvarvtal (r/min)		3000
Diámetro de cilindros, mm	Alesaggio mm	Cylinderdiameter, mm		88,9
Carrera, mm	Corsa mm	Slaglängd mm		90
Cilindrada, dm ³	Cilindrata dm ³	Slagvolym, dm ³	1.12	1.68
Régimen al vacío, (rpm)	Velocità al minimo (giri/min.)	Tomgångsvarvtal (r/min)		750-800
Sentido rotación contra volante	Senso di rot., visto del volante	Rotationsriktning sett mot svänghjul		
Inclinac. máx. en navegación	Inclin. max. del motore in navigazione	Max. bakåtlutning under gång		15°
Inclinac. lateral máx. en navegación	Inclin. laterale max. in navigazione	Max. sidolutning under gång		15°
Peso motor incl. inversor, kg	Peso del motore compr. inv. kg	Motorvikt inkl. backslag, kg	221	281
Peso motor incl. cola 120S, kg	Peso del motore compr. trasm. 120S kg	Motorvikt inkl. drev 120S kg	238	308
Combustible	Combustibile	Bränsle		Autodiesel
VALVULAS	VALVOLE	VENTILER		
Juego válv., adm. mm, motor caliente	Gioco valvole a motore caldo, aspir. mm	Ventilspel inlopp mm, varm motor		0.30 (0.012")
Juego válv., esc., mm, motor caliente	Gioco valvole a motore caldo, scar. mm	Ventilspel, utlopp mm, varm motor		0.35 (0.014")
Disp descompr., descen. máx. válv. esc., mm	Decompre., spost. valv. di scar. mm	Dekompr. nedtryckn. mm		0.5

SISTEMA DE LUBRICACION, MOTOR

IMPIANTO DI LUBRIFICAZIONE MOTORE

SMÖRJSYSTEM MOTOR

Cap. aceite lit, sin filtro	Capienza olio motore lit. escl. il filtro	Oljerymd, motor lit. exkl. filter	2.6	4.4
Cap. aceite, lit, con filtro	Capienza olio motore lit. compr. il filtro	Oljerymd, motor lit. inkl. filter	2.9	4.7
Calidad de aceite	Qualità olio	Oljekvalitet		CD
Viscosidades, sobre +10°C	Viscosità con temp. sopra i 10°C	Viskositet, över+10°C		SAE 15 W-40 ²⁾
bajo +10°C	con temp. sotto i 10°C	under +10°C		SAE 10W ³⁾
Desmultipl. con reduct. Inversor MS2	Rapporto di riduzione, inv. MS2	Utväxling MS2-backslag med red.		2.4:1 alt 3.0:1
Capacidad de aceite, lit MS2	Capienza olio lt. MS2	växel Oljerymd, MS2 lit		0.8
Calidad de aceite (igual que motor)	Qualità olio (la stessa del motore)	Oljekvalitet (samma som motorn)		CD
Viscosidades, sobre +10°C	Viscosità con temp. sopra i 10°C	Viskositet, över+10°C		SAE 20/W30 ²⁾
bajo +10°C	Viscosità con temp. sotto i 10°C	under +10°C		SAE 10W ³⁾
Relación, cola velero 120S	Rapporto di rid. trasm. 120S	Utväxling drev 120S		2.20:1
Capacidad de aceite, lit. 120S	Capienza olio lt. 120S	Oljerymd 120 S lit		2.2
Calidad de aceite (igual que motor)	Qualità olio (da stessa dell'olio motore)	Oljekvalitet (samma som motorn)		CD
Viscosidades (igual que motor)	Viscosità (la stessa dell'olio motore)	Viskositet (samma som motorn)		
Termostato, comienza a abrir a °C (°F)	Termostato, comincia ad aprire a °C (°F)	Termostat, börjar öppna vid °C (°F)		60 (140)
Termostato, completamente abierto °C (°F)	Termostato, compl. aperto a °C (°F)	Termostat, är fullt öppen vid °C (°F)		74 (165)

SISTEMA ELECTRICO

IMPIANTO ELETTRICO

ELEKTRISKA SYSTEMET

Tension de la batería V	Voltaggio batteria	Batterispänning, volt		12
Capacidad de la batería, máx. Ah	Amperaggio massimo batteria max Ah	Startmotorbatteri, max. Ah	70	90
Potencia motor de arranque, kW	Motorino di avviamento kW	Startmotoreffekt, kW	1,1	1,9
Potencia del alternador A (W)	Alternatore A (W)	Generatoreffekt A (W)		50 (14 x 50)
Peso específico electrólito batería:	Peso específico dell'elettrolito batteria	Batterielektrolytens specifika vikt		
Debe ser recargada a g/cm ³	Ricaricare la batteria a g/cm ³	Laddning utföres vid g/cm ³		1.230
Batería completamente cargada, g/cm ³	Batería compl. carica a g/cm ³	Fulladdat batteri, g/cm ³		1.275-1.285

PARES DE APRIETE

COPPIE DI SERRAGGIO

ÅTDRAGNINGSMOMENT

Tuercas de culata Nm (kpm)	Dadi testata, Nm (kgm)	Cylinderlocksmuttrar Nm (kpm)		110 (11)
Tuercas soporte inyectores Nm (kpm)	Dadi portainiettori, Nm (Kgm)	Muttrar för insprutarens ok Nm (kpm)		20 (2.0)

1) Potencia hélice según DIN Leistung B für Dauerbetrieb

1) Potenza all'asse elica secondo le norme DIN Leistung B für Dauerbetrieb

1) Propelleraxeffect enl. DIN Leistung B für Dauerbetrieb

2) Aceite Volvo Penta CD, double grade

2) Volvo Penta CD Multigrade

2) Volvo Penta CD olja Double Grade

3) Aceite CD, single grade

3) CD Unigrade

3) CD olja Single Grade

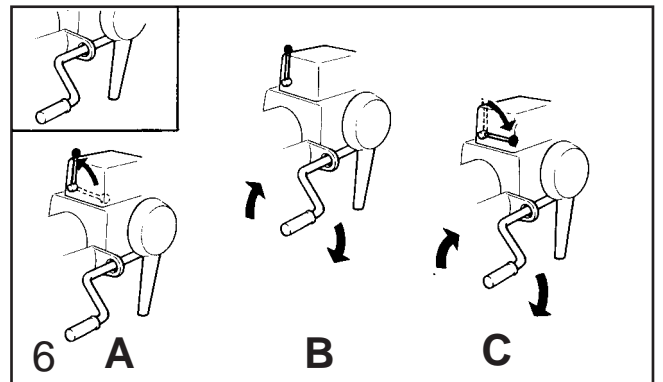
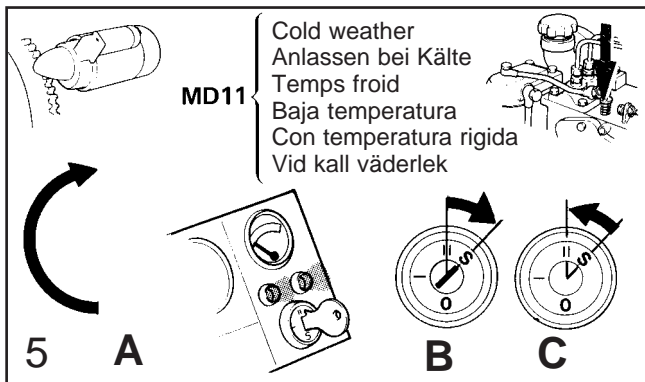
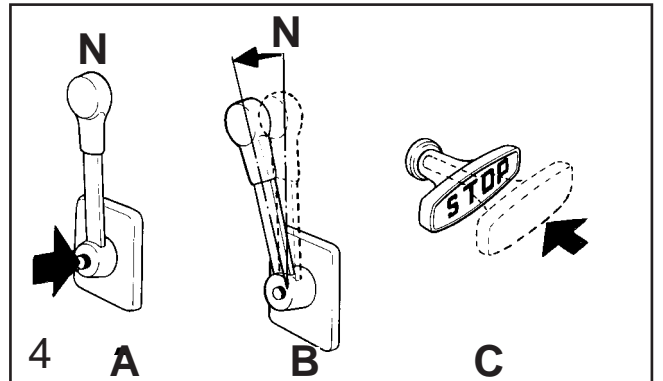
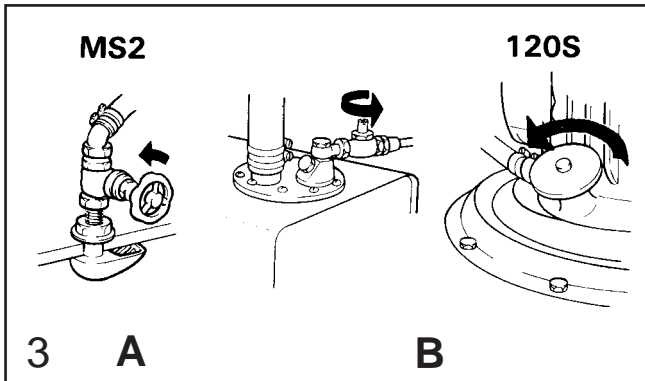
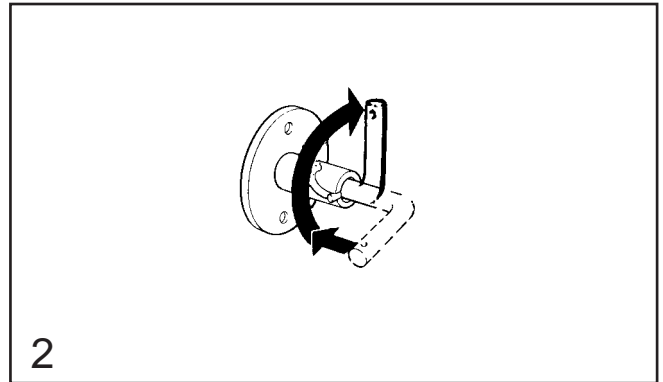
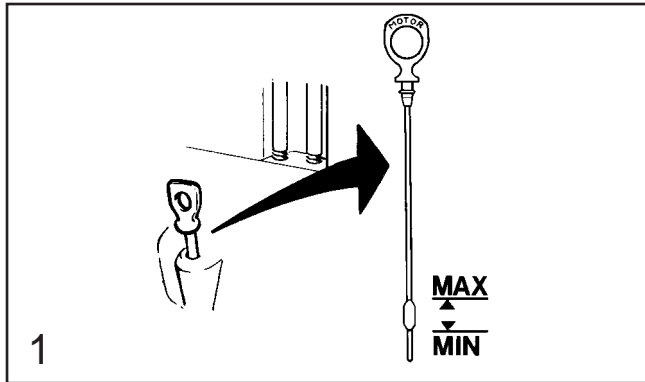

Aviso!
Attenzione!
Varning

**MD17**

The engine has a built-in automatic cold-start device.
Der Motor hat eine eingebaute automatische Kaltstartvorrichtung.

Le dispositif de démarrage à froid est incorporé dans le moteur et actionné automatiquement.

El motor lleva incorporado un dispositivo de arranque en frío automático.

Il motore è provvisto di starter automatico.

7 *Motorn har automatisk köldstartanordning.*

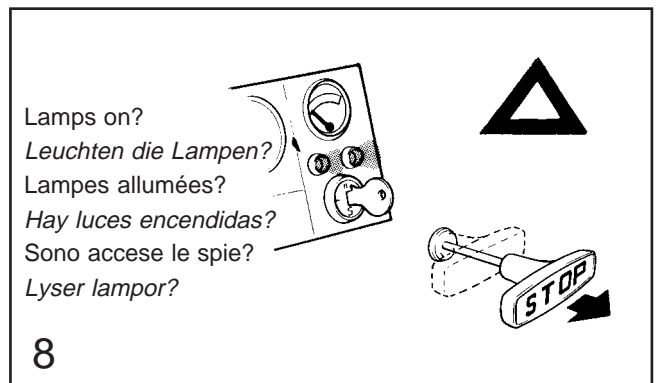

The main switch must never be switched off until the engine has stopped.

Der Hauptschalter darf nicht ausgechaltet werden bevor der Motor stillsteht.

Ne jamais couper le circuit principal par le robinet de batterie avant que le moteur ne se soit complètement immobilisé.

El interruptor principal no debe ser desconectado hasta que el motor esté parado.

Non scollegare mai l'interruttore-generale fino a che il motore è completamente fermo.

9 *Huvudströmbrytaren får ej kopplas ifrån förrän motorn står stilla.*

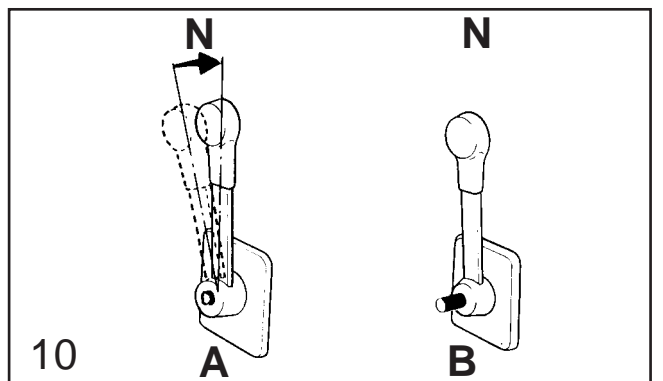

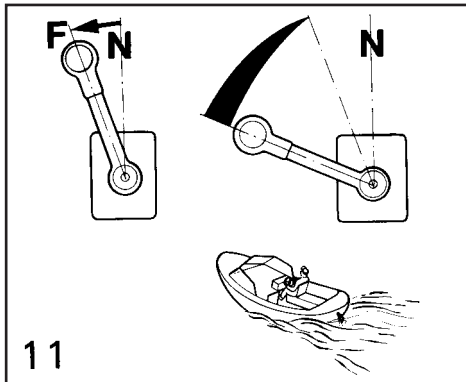

11

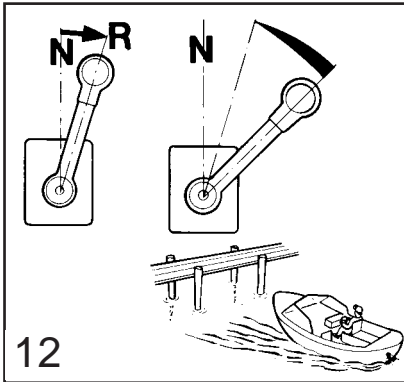

12

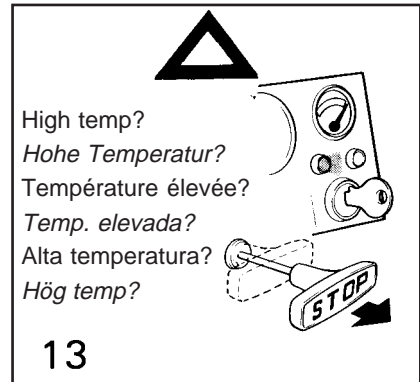

High temp?
Hohe Temperatur?
Température élevée?
Temp. elevada?
Alta temperatura?
Hög temp?

13



Place controls in neutral when sailing.
Bedienungshebel beim Segeln in Leerlaufstellung stellen.

Mettre la commande en position neutre lors de la navigation à voile.

Al navegar a vela, poner el mando en la posición retroceso.

Portare il comando sulla posizione di folle durante la navigazione a vela.

14 *Ställ reglaget i neutralläge vid segling.*



Place controls in reverse position when sailing.
Bedienungshebel beim Segeln in Stellung zurück stellen.

Mettre la commande en position inversée lors de la navigation à voile.

Al navegar a vela, poner el mando en la posición de retroceso.

Portare il comando sulla posizione di marcia indietro durante le navigazione a vela.

14 *Ställ reglaget i backläge vid segling.*

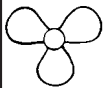

Start and run engine 5 mins. every 10 hours on long-distance sailing trips.

Bei langdauerndem Segein den Motor alle 10 Stunden anlassen und 5 Minuten fahren.

Démarrer et faire tourner le moteur 5 mn toutes les 10 heures lors des longues croisières.

En singladuras prolongadas a vela, arrancar el motor cada 10 horas y hacerlo marchar 5 minutos en cada ocasión.

Avviare il motore e lasciarlo funzionare per 5 min. ogni 10 ore di navigazione a vela.

15 *Starta och kör motorn 5 min var 10:e timma vid långsegling.*

The main switch must never be switched off until the engine has stopped.

Der Hauptschalter darf nicht ausgeschaltet werden bevor der Motor stillsteht.

Ne jamais couper le circuit principal par le robinet de batterie avant que le moteur ne se soit complètement immobilisé.

El interruptor principal no debe ser desconectado hasta que el motor esté parado.

Non scollegare mai l'interruttore generale fino a che il motore è completamente fermo.

16 *Huvudströmbrytaren får ej kopplas ifrån förrän motorn står stilla.*

Shutdown procedure *Como parar el motor*

Beendigung der Fahrt Procedura per l'arresto del motore

Fin de marche *Avslutad körning*

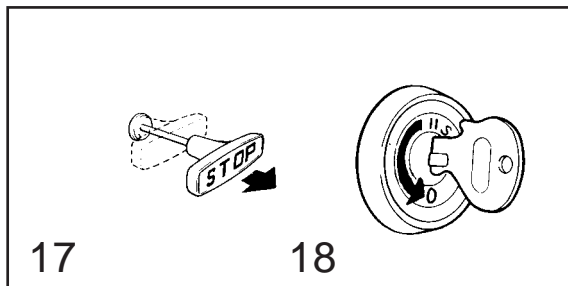

17

18

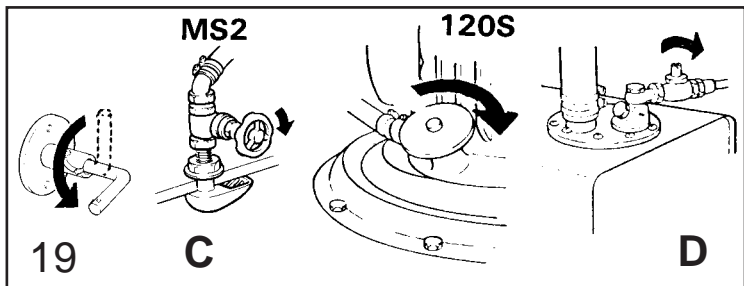

19

C

D

If risk of frost
Bei Frostgefahr
Risque de gel
Si hay riesgo de heladas
Con rischio di gelo
Vid frostrisk

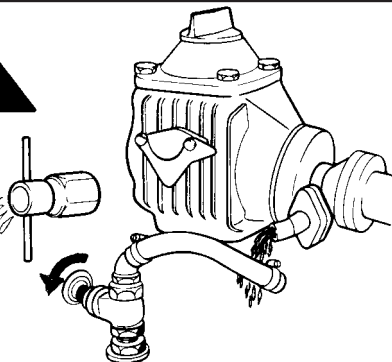

20

20

Do not allow to drain unsupervised
Kein Ablassen sondern überwachung
Pas de vidange
Al vaciar, vigilar siempre
Nessun scario senza sorveglianza
Ingen avtappning utan övervakning



Every 14 days
 Alle 14 Tage
 Tous les 15 jours
 Ogni 15 giorni
 Cada 15 dias
 Var 14:e dag

21

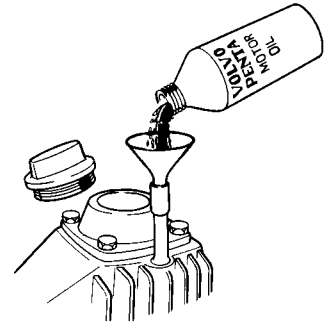
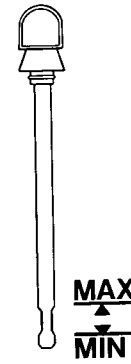
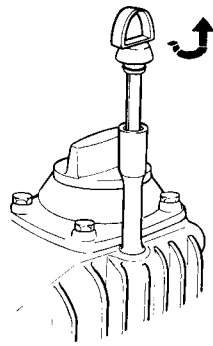

22

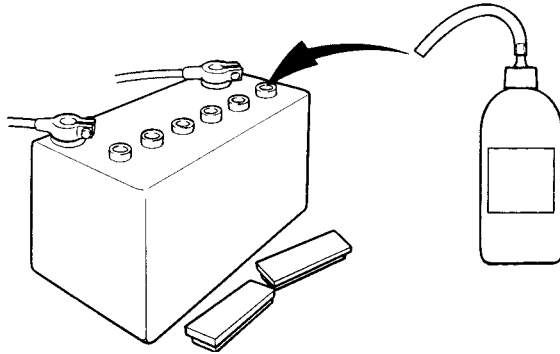

Distilled water.
 Destilliertes Wasser.
 Eau distillée.
 Agua destilada.
 Acqua distillata.
 Destillerat vatten.

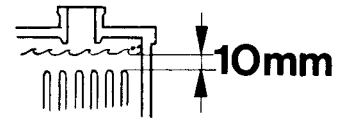

23

Belt tension
 Riemenspannung
 Tension de courroie
 Tensado de correas
 Tensione delle cinghia
 Remspänning

23

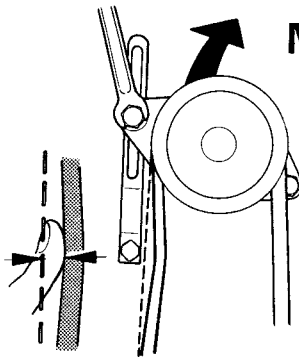

MD11

5 mm

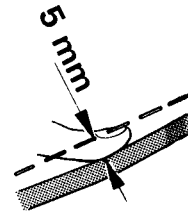

MD17

Every 50 hours
 Alle 50 Betriebsstunden
 Toutes les 50 heures
 Cada 50 horas
 Ogni 50 ore
 Var 50:e timma

24

Allow engine to warm up
 Warmfahren
 Réchauffer
 Dejar marchar el motor hasta
 que se caliente
 Riscaldare il motore
 Varmkör

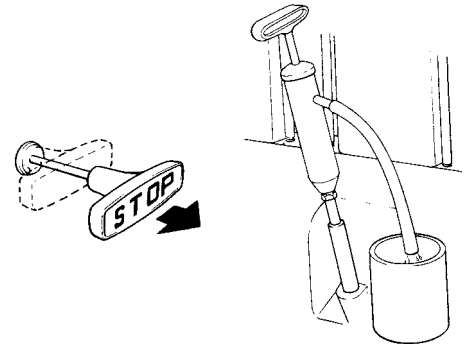

25



25

MD11 = 2,6 lit.
 MD17 = 4,4 lit.

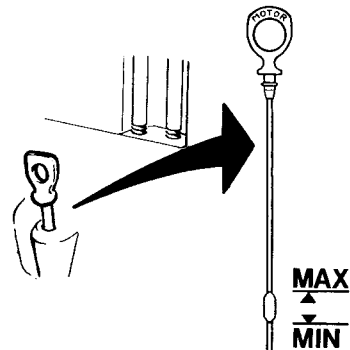

Every 100 hours

Alle 100 Betriebsstunden

Toutes les 100 heures

Cada 100 horas

Ogni 100 ore

Var 100:e timma

See 24

Siehe 24

Voir 24

Ver 24

Ved. 24

Se 24

26

Oil filter
Ölfilter
Filtre à huile
Filtro de aceite
Filtro dell'olio
Oljefilter

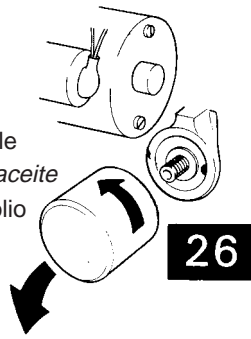

Oil
Öl
Huile
Aceite
Olio
Olja

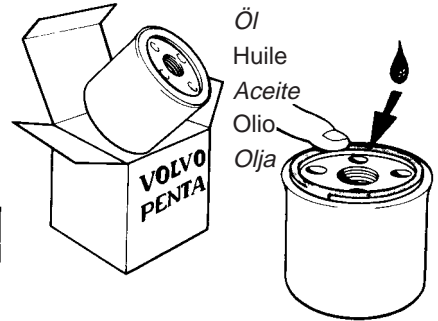

Screw on the filter by hand until it touches the contact surface. Turn the filter a further half turn.

Das Filter von Hand aufschrauben, bis es die Anliegende fläche knapp berührt. Danach das Filter eine weitere halbe Drehung anziehen.

Visser ensuite le filtre à la main jusqu'à ce qu'il effleure juste la surface de contact. Serrer

Enroscar el filtro con la mano hasta que apenas roce con la superficie de contacto. Enroscar el filtro una media vuelta más.

Avvitare il filtro a mano fino a che va a toccare la superficie di contatto. Avvitare quindi di un ulteriore mezzo giro ma non di più.

Skruva på filtret för hand tills det just berör anliggningsytan. Skruva åt filtret ytterligare ett halvt varv.

See 25

Siehe 25

Voir 25

Ver 25

Ved. 25

Se 25

28

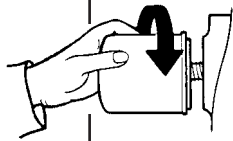

27



If required

Bei Bedarf

En cas de besoin

Se necessario

Si fuse necesario

Vid behov



High temp?
Hohe Temperatur?
Température élevée?
Temp. elevada?
Alta temperatura?
Hög temp?

29

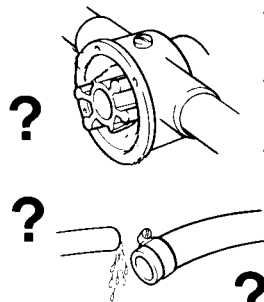

Thermostat
Thermostat
Thermostat
Termostato
Termostato
Termostat

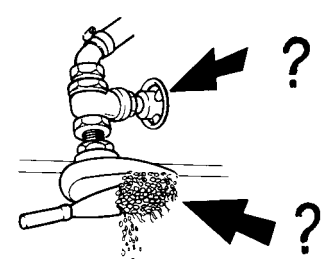
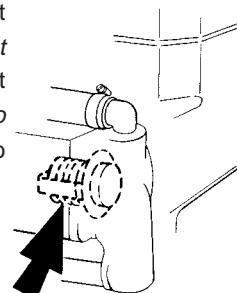

MS2

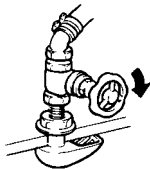

120S

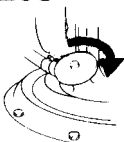

30

31

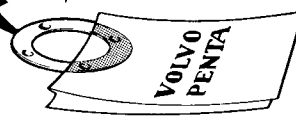
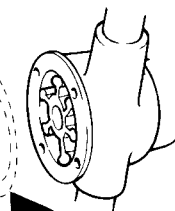
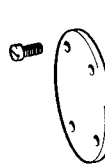
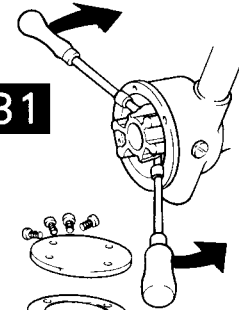

31

MS2

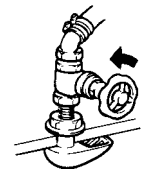

120S

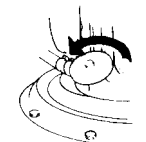

32

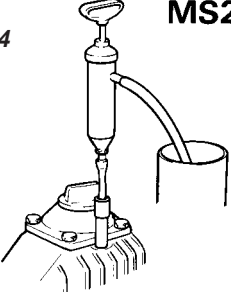
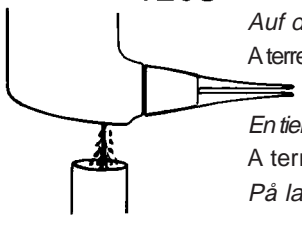
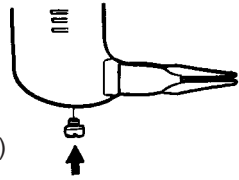
See 24 Siehe 24 Voir 24 Ver 24 Ved. 24 Se 24 33	 <p>MS2 In water Im Wasser A l'eau En el agua In mare I sjön</p>	 <p>120S On land Auf dem Land A terre En tierra A terra (a secco) På land</p>		See 26 Siehe 26 Voir 26 Ver 26 Ved. 26 Se 26
---	--	---	---	---

Fill up with VP oil.
VOLVO PENTA-Öl auffüllen.
Remplir d'huile Volvo Penta.
Poner aceite Volvo Penta.
Rifornire con olio Volvo Penta.
Fyll på Volvo Penta olja.

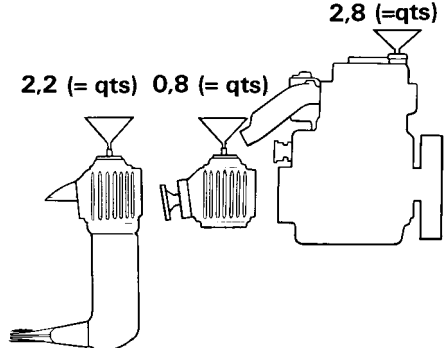

2.2 (= qts) 0.8 (= qts) 2.8 (=qts)

34

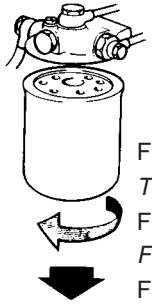

35

Fuel filter
Treibstofffilter
Filtre à carburant
Filtro de combustible
Filtro per il carburante
Bränslefilter

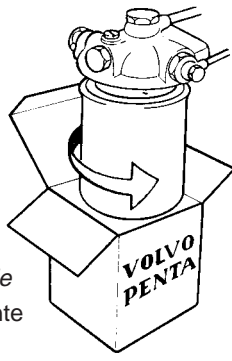

35

Fuel strainer
Treibstoffsieb
Crépine à carburant
Colador de combustible
Filtro a rete per il carburante
Bränslesil

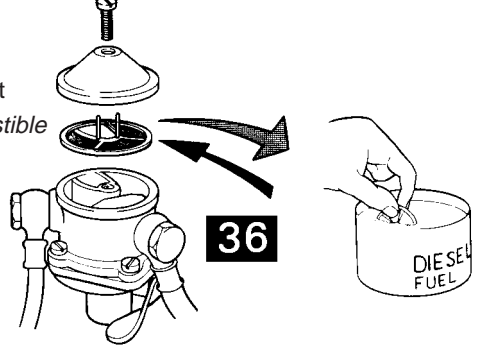

36

36

Venting
Entlüften
Purge
Purga
Spurgo
Luftning

Primer pump.
Handpumpe.
Pompe à main.
Cebador manual.
Pompa manuale.
Handpump.

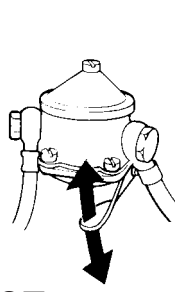

37

37

Open venting screw. Pump out air by hand. Close.
Entlüftungsschraube öffnen. Entlüften im Handpumpe. Schließen.
Ouvrir la vis de purge. Pomper l'air manuellement. Fermer.
Abrir el tornillo de purga. Purger el aire con el cebador manual. Cerrar.
Aprire la vite di aerazione. Eseguire lo spurgo dell'aria pompando a mano. Chiudere.
Öppna luftskruven. Handpumpa ut luften. Stäng.

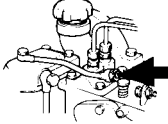

38

Open venting screw. Pump out air by hand. Close.
Entlüftungsschraube öffnen. Entlüften im Handpumpe. Schließen.
Ouvrir la vis de purge. Pomper l'air manuellement. Fermer.
Abrir el tornillo de purga. Purger el aire con el cebador manual. Cerrar.
Aprire la vite di aerazione. Eseguire lo spurgo dell'aria pompando a mano. Chiudere.
Öppna luftskruven. Handpumpa ut luften. Stäng.

38

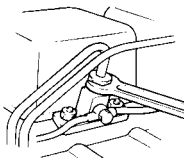

39

Open the nut. Turn the engine by using the starter motor until fuel flows out from the delivery pipes.
Mutter öffnen. Motor mit dem Anlasser durchziehen, bis Kraftstoff an den Druckrohren ausströmt.
Ouvrir l'écrou. Mettre le moteur en marche au démarreur jusqu'à ce que le carburant s'échappe du tuyau de refoulement.
Abrir la tuerca. Hacer funcionar el motor con la ayuda del motor de arranque hasta que salga combustible por los tubos de presión.
Aprire il dado. Far girare il motore con il motorino di avviamento fino a che il gasolio fuoriesce dalle tubazioni di mandata agli iniettori.
Öppna muttern. Kör runt motorn med startmotorn tills bränsle kommer fram.

39

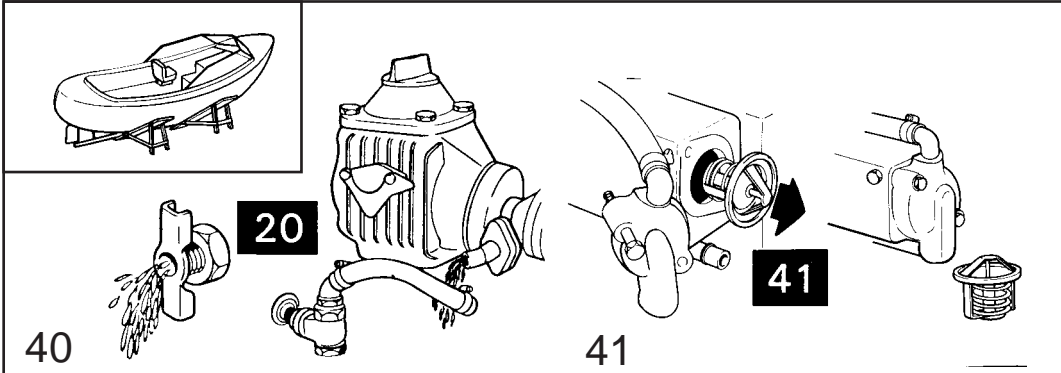
<p>Cooling system Kühlanlage Refrroidissement Refrigeración Reffreddamento Kylsystem</p>	 <p>40</p> <p>20</p> <p>41</p>
--	--

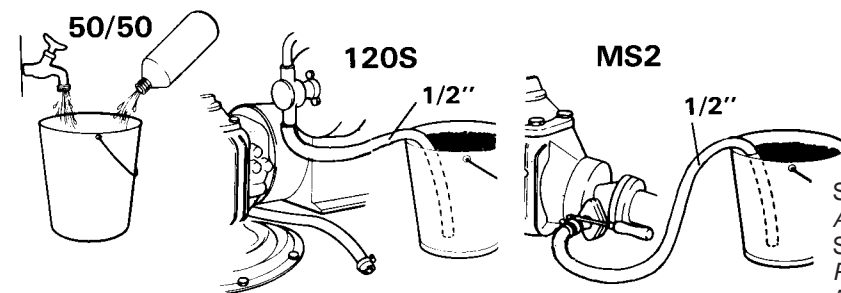
 <p>50/50</p> <p>120S</p> <p>1/2"</p> <p>MS2</p> <p>1/2"</p>	<p>Start See 4, 5, 6. Anlassen Siehe 4, 5, 6. Démarrer Voir 4, 5, 6. Arrancar Ver 4, 5, 6. Avviare Ved. 4, 5, 6. Starta Se 4, 5, 6.</p> <p>Stop when the tank is empty. Anhalten, wenn das Geläß leer ist. S'arrêter quand le récipient est vide. Parar cuando se ha vaciado el recipiente. Arrestare il motore quando il recipiente. Stanna när kärlet är tomt.</p>
--	--

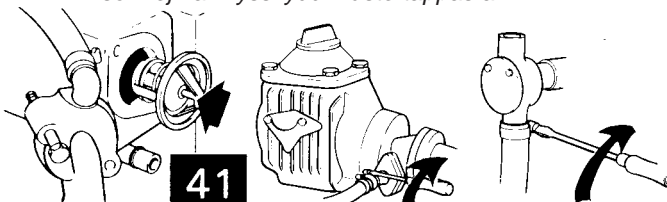
<p>Do not drain glycol mixture. Other mixtures without anti-freeze must be drained. <i>Das Glykologemisch ist nicht abzulassen. Ein anderes Gemisch, das keinen Frostschutz hat, muß abgelassen werden.</i> Ne pas vidanger le mélange au glycol. Tout autre mélange ne contenant pas d'antigel devra être vidangé. <i>No vaciar la mezcla de glicol. Vaciar cualquier otra mezcla que no tenga anticongelante.</i></p>	<p>La miscela refrigerante non va scaricata. Trattandosi di altra miscela che non contenga anticongelante eseguirne lo scarico. <i>Glykolblandningen tappas ej av. Annan blandning som ej har frysskydd måste tappas av.</i></p>  <p>41</p>
---	---

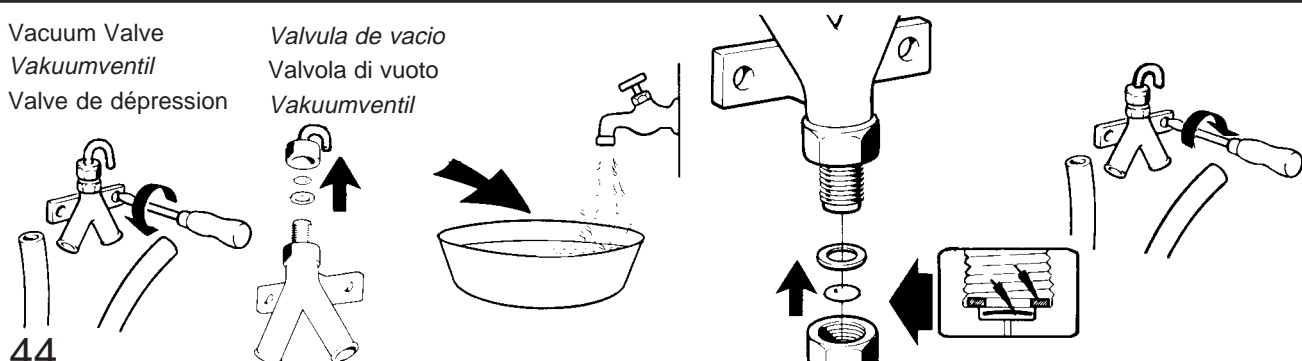
<p>Vacuum Valve Vakuumentil Valve de dépression</p>	<p>Valvula de vacío Valvola di vuoto Vakuumentil</p>	 <p>44</p>
---	--	--

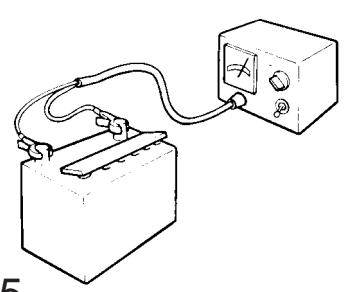

45

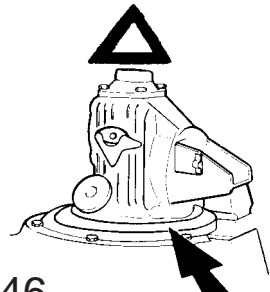
 <p>46</p>	<p>The flexible rubber seal must be replaced each 5th year. <i>Die Gummidichtung soll alle 5 Jahre gewechselt werden.</i> Le joint d'étanchéité en caoutchouc doit être remplacé tous les 5 ans. <i>La junta de goma debe cambiarse cada 5 años.</i> Le membrana di gomma deve essere sostituita ogni 5 anni. <i>Gummitätningen skall bytas vart 5:e år.</i></p>
---	--

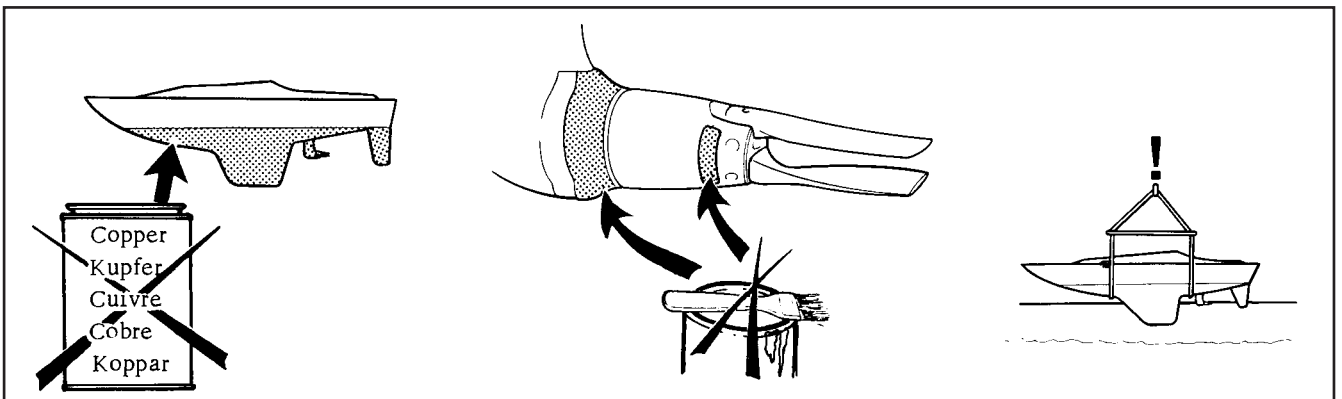
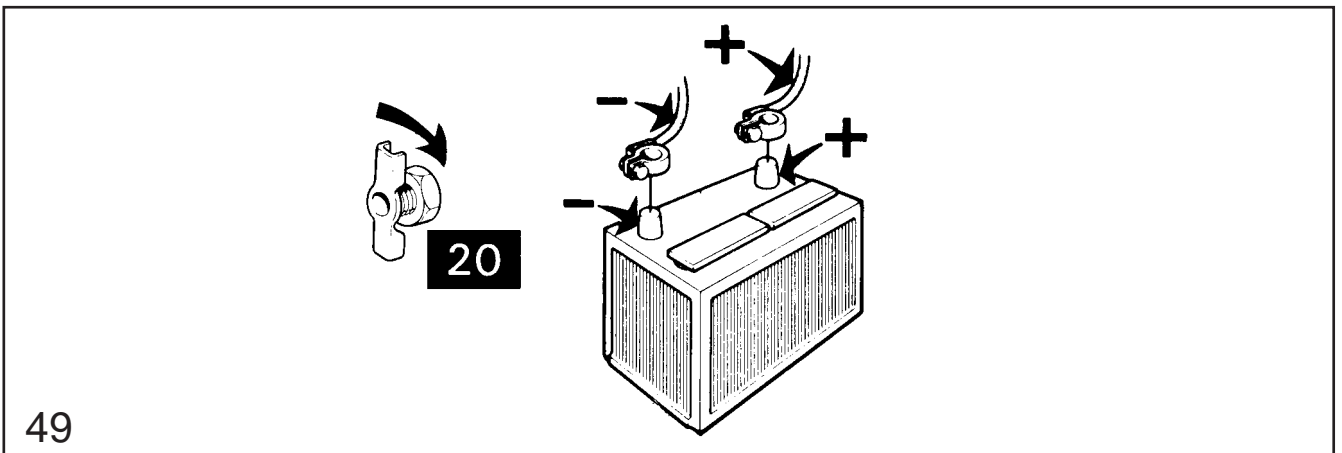
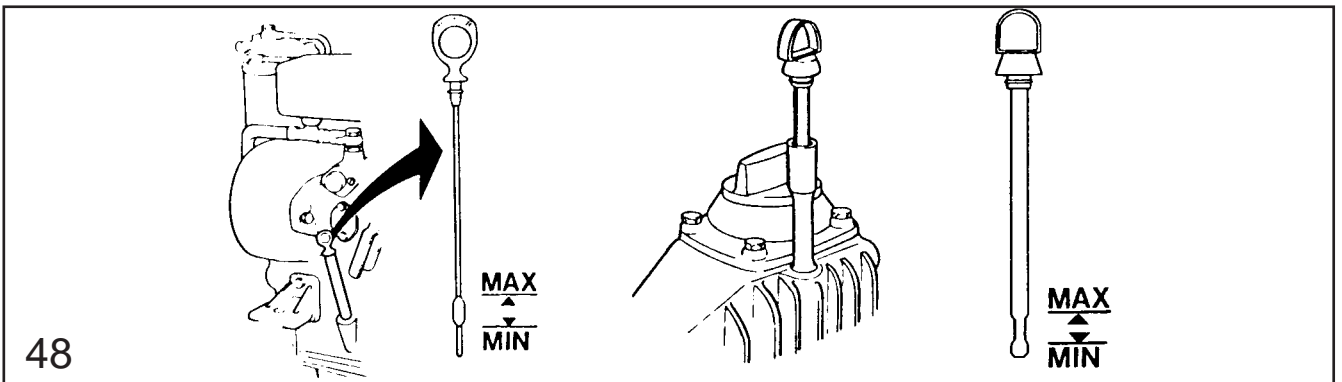
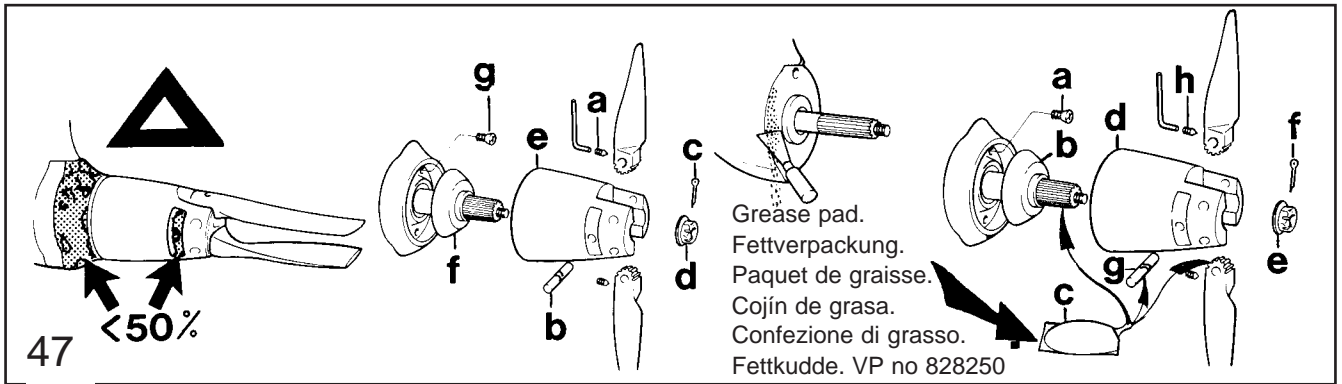

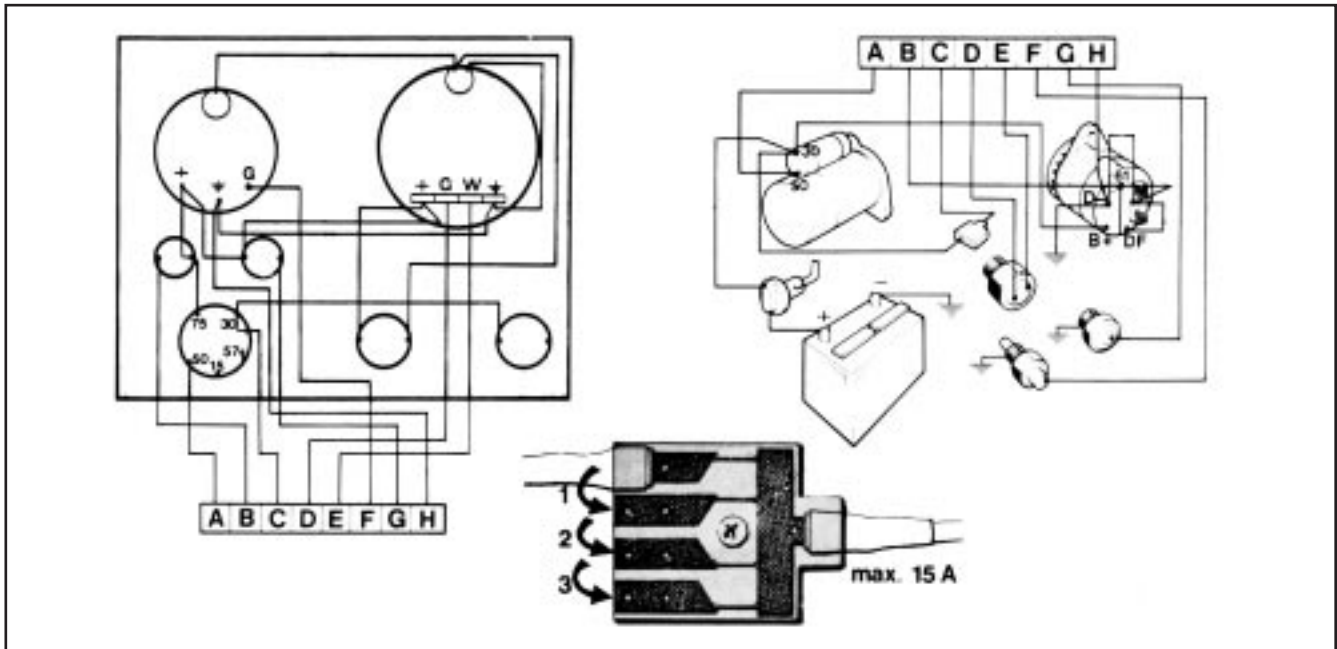

Touch-up paint for S-drive
Ausbesserungsfarbe für Segelbootantrieb.
Peinture de retouches pour hélice de transmission S.
Pintura para retoques, para la transmisión S.
Vernice per ritocchi, trasmissione S.
Bättringsfärg för S-drev.
VP no 1141567-6

Grease pad for S-drive propeller.
Fettverpackung für den Propeller des Segelbootantriebs.
Paquet de graisse pour hélice de transmission S.
Cojín de grasa para la hélice de la transmisión S.
Confezione di grasso per elica trasmissione S.
Fettkudde för S-drevspropellern.
VP no 828250-1

Glycol
1141646-8 (5 lit.)
1141645-0 (1 lit.)

VP engine oil can also be used for winter lay-up.
For periods longer than 6 months, use special preservative oil.

Das Motoröl von VOLVO PENTA kann auch für das Auflegen im Winter verwendet werden. Bei längerem Auflegen des Bootes als 6 Monate, soll ein besonderes Konservieröl angewendet werden.

Huile de moteur Volvo Penta pouvant aussi être utilisée lors de la mise en conservation hivernale. Pour des durées de conservation de plus de 6 mois, une huile de conservation spéciale devra être utilisée.

Aceite Volvo Penta para motor. Puede utilizarse también para el invernaje. En almacenamientos superiores a 6 meses deberá utilizarse un aceite especial de conservación.

Oil per motori Volvo Penta che può essere impiegato anche per l'alaggio dell'imbarcazione durante la stagione fredda. Se il periodo di conservazione è superiore a 6 mesi, impiegare olio conservante speciale.

Volvo Penta motorolja som även kan användas vid vinterupplägning. Vid längre upplägning än 6 mån. bör speciell konserveringsolja användas.

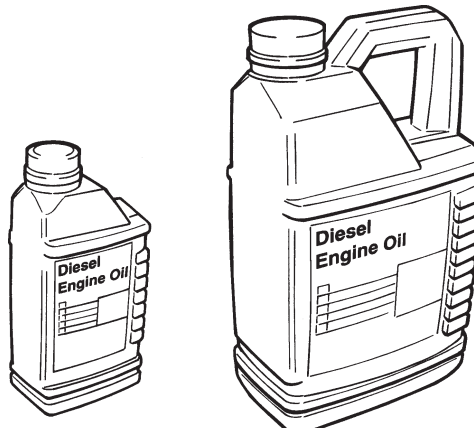

SAE 15 W-40
1 lit. = VP no 1141626-0
5 lit. = VP no 1141627-8

IMPORTANT INFORMATION

Stop the engine before opening the hatch to the engine compartment. An engine which is in operation has rotating and moving parts which are dangerous to touch.

Bear in mind the risk of a fire. All engine fuel is inflammable.

The cooling system is filled with liquid and it should be drained when there is risk of frost. Note that in certain cases a suction action may occur when the sea-water system is being drained. Close all drainage points when the boat is not under constant supervision. Incorrectly performed drainage can cause the boat to become filled with water and sink.

WICHTIGE INFORMATION

Stellen Sie den Motor ab, bevor die Motorraumluke geöffnet wird! Ein laufender Motor hat rotierende und bewegliche Teile, deren Berühren gefährlich ist

Denken Sie an die Feuergefahr. Der Motorkraftstoff ist feuergefährlich.

Die Kühlanlage ist flüssigkeitsgefüllt. Die Anlage ist bei Frostgefahr zu entleeren. Beachten, daß beim Ablassen der Seewasseranlage in gewissen Fällen ein Hebereffekt entstehen kann. Verschließen Sie alle Ablassstellen sorgfältig, wenn das Boot nicht ständig überwacht wird. Falsch ausgeführte Ablassstellen können dazu führen daß des Boot mit Wasser gefüllt wird und sinkt.

INFORMATION IMPORTANTE

Arrêtez le moteur avant d'ouvrir le compartiment moteur. Un moteur en marche possède des pièces tournant rapidement et pouvant être dangereuses. Pensez au risque d'incendie. Tout carburant est facilement inflammable.

Le système de refroidissement est plein de liquide. Videz celui-ci en cas de risque de gel. Notez que dans certains cas, un phénomène de suction peut se produire lors de la vidange du système d'eau de mer. Fermez tous les robinets de vidange lorsque le bateau n'est pas sous surveillance constante. Une vidange mal effectuée peut entraîner le remplissage d'eau du bateau qui peut couler.

INFORMACION IMPORTANTE

Detener el motor antes de abrir la tapa del recinto del mismo. Un motor en marcha tiene piezas móviles y en rotación que es muy peligroso tocarlas.

Tener presente el peligro de incendios. Cualquier combustible de motor es inflamable.

El sistema de refrigeración está lleno de líquido. Vaciarlo si hay peligro de heladas. Tener presente que en ciertos casos al vaciar el sistema de agua dulce puede producirse efecto de sifón. Cerrar todos los puntos de vaciado cuando la embarcación no esté cuidada permanentemente. Un vaciado hecho erróneamente puede provocar que la embarcación se llene de agua y se hunda.

IMPORTANTE

Arrestare il motore prima di aprire lo sportello di ispezione. I ruotismi e le parti mobili di un motore in marcia possono causare seri danni alle persone.

Prevenire ogni rischio di incendio: il combustibile è altamente infiammabile.

Il circuito di raffreddamento è rifornito di liquido. Scaricare l'impianto quando si prevedono temperature rigide. Tener presente che, in alcuni casi, nello scaricare il sistema dell'acqua salata potrebbe verificarsi l'effetto sifone. Se l'imbarcazione non è sorvegliata, chiudere tutti i punti di scarico. Un procedimento errato dello scarico può provocare intromissione di acqua nello scafo, con conseguente affondamento.

VIKTIG INFORMATION

Stanna motorn innan motorrumsluckan öppnas! En motor som är igång har roterande och rörliga delar som är farliga att vidröra.

Tänk på brandfaran. Allt motorbränsle är brandfarligt

Kylsystemet är vätskefyllt. Tappa av systemet vid frostfara. Observera att hävertverkan i vissa fall kan uppstå vid avtappning av sjövattnet. Stäng alla avtappningsställen då båten ej har ständig tillsyn. Felaktigt utförd avtappning kan leda till att båten vattenfylls och sjunker.

